

**Frame 1 Trolley Dimensions**  
**-02 drum w/o limit switch**

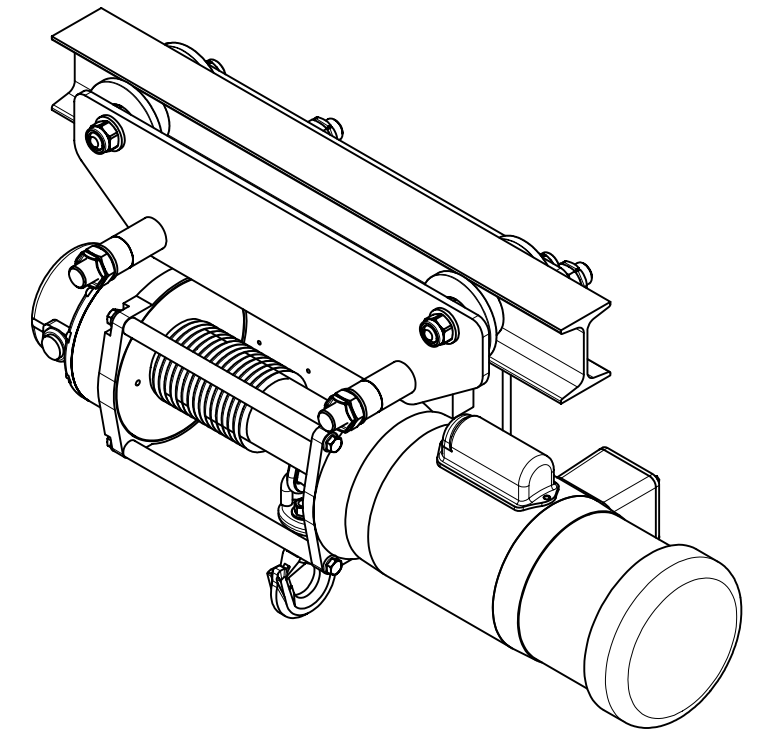
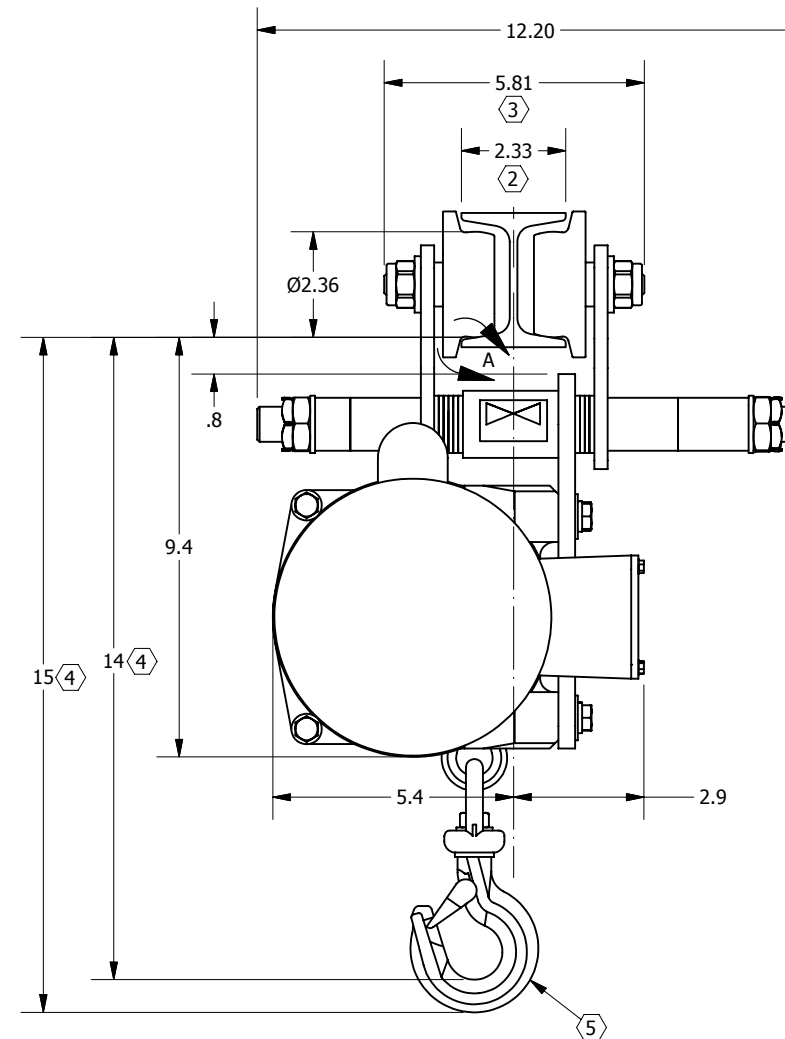
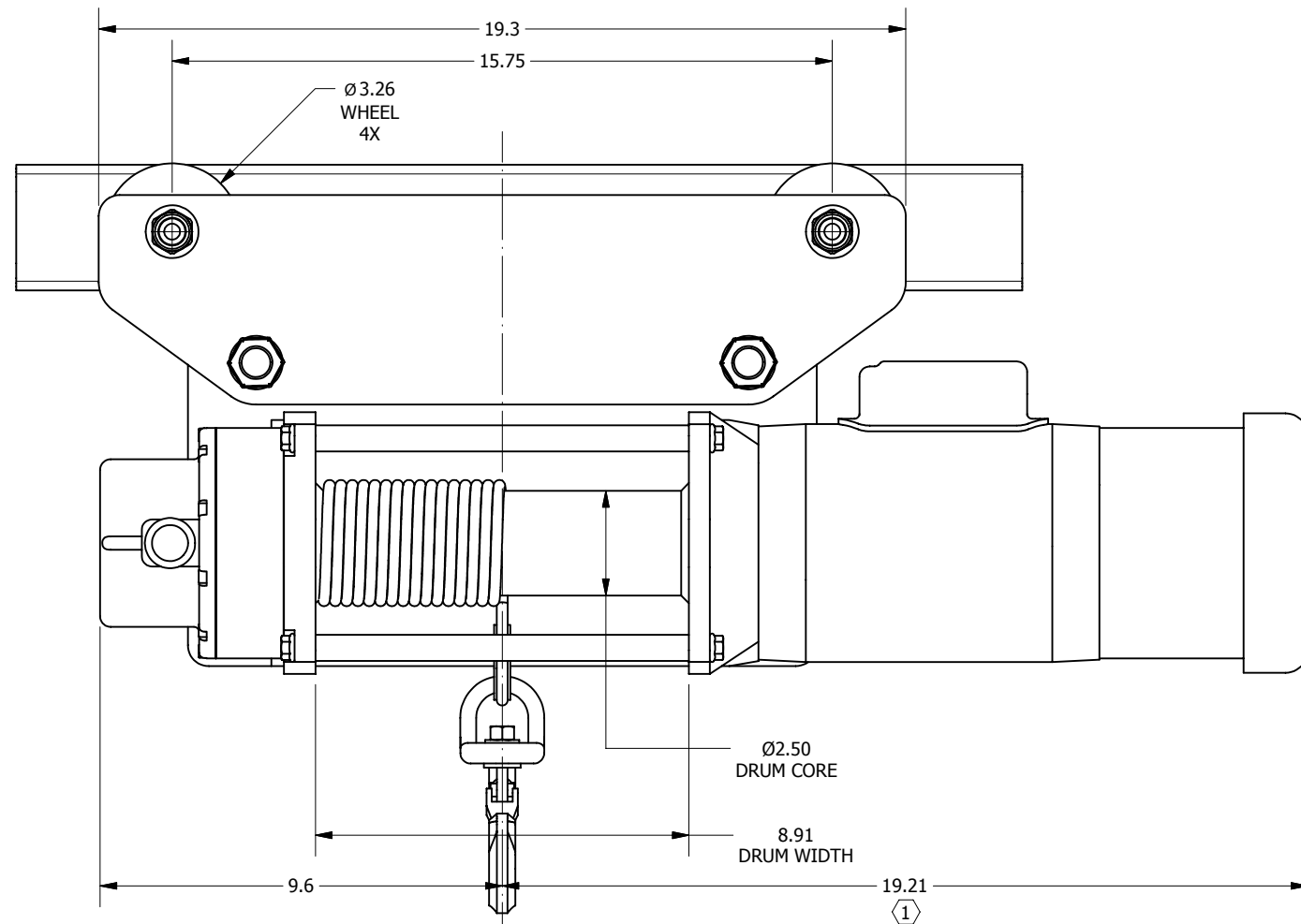

**NOTES**

- ① Dimension varies with hoist model; shown with HD2000-1A34-F-02.
- ② Minimum flange width; see table for acceptable range of I-beam width.
- ③ Dimension varies with flange width; shown with S3X5.7 I-beam.
- ④ Dimension when swivel hook is fully raised.
- ⑤ One-ton swivel hook shown; other cable fittings available.
- 6. Compatible with all standard and most wide flange beams.

Working Load*	Minimum Beam Height	I-Beam Width	Net Weight (Approx)
2000 lbs.	3.0"	2.3"-8.7"	150 lbs. w/o hoist motor

Trolley working load may exceed hoist working load depending on hoist model and wire rope layer. Do not exceed hoist working load.

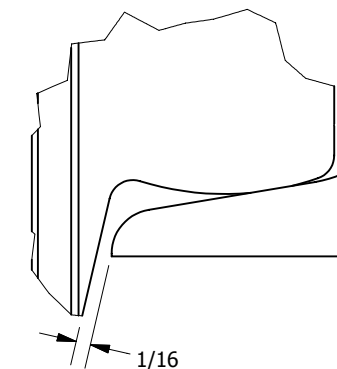

**DETAIL A**

**ADJUSTMENT ILLUSTRATION & INSTRUCTIONS**  
 The correct trolley setting is the beam flange width plus approximately 1/16" running clearance on each side of the flange; the clearance should not exceed 3/16".

Move the spacing washers on either side of the trolley side plates to adjust as required.

After adjustment, tighten the trolley pin nuts and locking nuts securely.

**ALLIED POWER PRODUCTS, INC.**

**THE WINCH & HOIST SPECIALISTS**

6590 SW Fallbrook Place, Beaverton OR 97008

Toll Free: 800.248.4896 Phone: 503.626.2654 Fax: 503.646.1996