

CAUTION: The final determination as to the suitability of this product for any purpose is solely that of the user. Columbia products are not to be used to lift people or to lift anything over people.

DIMENSIONAL DATA

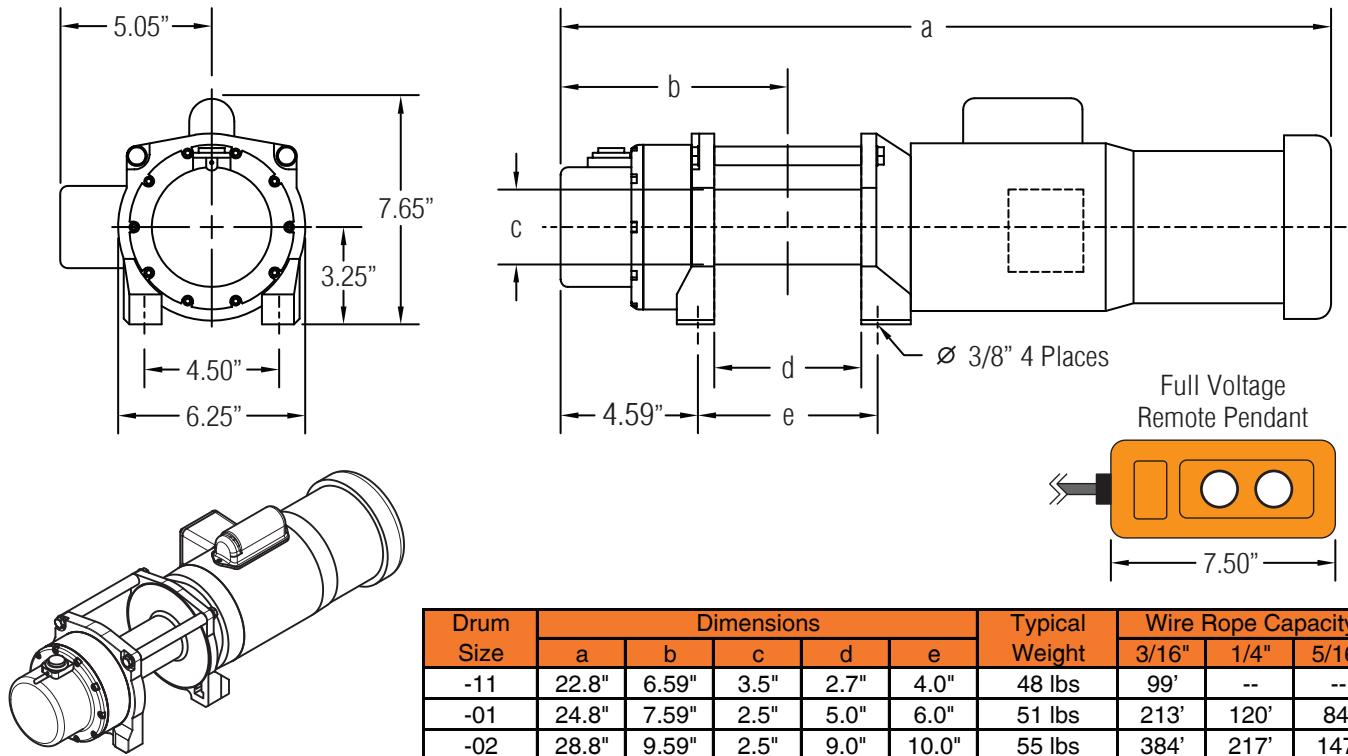

Drum Size	Dimensions					Typical Weight	Wire Rope Capacity		
	a	b	c	d	e		3/16"	1/4"	5/16"
-11	22.8"	6.59"	3.5"	2.7"	4.0"	48 lbs	99'	--	--
-01	24.8"	7.59"	2.5"	5.0"	6.0"	51 lbs	213'	120'	84'
-02	28.8"	9.59"	2.5"	9.0"	10.0"	55 lbs	384'	217'	147'

PERFORMANCE

Model	Motor		Power Input		Gear Ratio	Calculated Performance					
	HP	RPM	Voltage	\varnothing		First Layer		Mean Drum		Full Drum	
						LBS	FPM	LBS	FPM	LBS	FPM
HD670 ¹	0.5	3450	115/230	1 \varnothing	113:1	670	29.5	567	34.7	493	39.9
HD900 ¹	0.5	3450	115/230	1 \varnothing	156:1	900	21.3	782	25.1	680	28.9
HD1300 ¹	0.5	3450	115/230	1 \varnothing	216:1	1300	15.4	1083	18.1	942	20.9
HD1000 ²	0.5	3450	115/230	1 \varnothing	113:1	1000	22.5	766	31.1	599	39.8
HD1450 ²	0.5	3450	115/230	1 \varnothing	156:1	1450	16.3	1057	22.6	827	28.8
HD2000 ²	0.5	3450	115/230	1 \varnothing	216:1	2000	11.8	1464	16.3	1146	20.8

¹ -11 drum

² -01 and -02 drums

Performance based on intermittent duty cycles.

Columbia winches and hoists are available for AC, DC, hydraulic or pneumatic power sources. Special models for any application can be supplied - please contact your distributor for details.

Distributed by:



1040 RUE ROBERT, ST-JÉRÔME, QC, J5L 2G9
 TÉL : (450) 565-6141 / MTL : (450) 476-6065
 FAX : (450) 565-3432 / EMAIL : info@reptech.ca
 SITE WEB : www.reptech.ca