



CRANES

**CEILING MOUNTED
WORK STATION BRIDGE CRANES & MONORAILS**

CAPACITIES: Up to 4000 lbs

SPANS: Up to 30'

ENCLOSED TRACKS: Steel, Aluminum & Stainless Steel

PRODUCTIVITY: Average 28% increase

GORBEL 1000 LBS. CAPACITY
FISHERS, NEW YORK, U.S.A. DO NOT EXCEED RATED CAPACITY

GORBEL 1000 LBS. CAPACITY
FISHERS, NEW YORK, U.S.A. DO NOT EXCEED RATED CAPACITY

Bridgeport CNC



A Class Above...

In Productivity.

In Safety.

In Ease of Positioning and Movement.

In Ease of Installation.

In Designs, Capacities, and Spans.

It's no wonder more and more businesses like yours are choosing Gorbel. As an innovator and leader in the enclosed track work station crane industry, Gorbel provides a wide variety of overhead solutions. Our work station systems include ceiling mounted bridge cranes and monorails (both covered in this brochure), free standing work station bridge cranes, and work station jib cranes. And we're also a leading manufacturer of high-performance manual and motorized jib cranes. All this, plus quick delivery and the industry's best warranty.



TABLE OF CONTENTS

General Information		
How to apply		2
Enclosed track design		3
Rigid runways		4
Mixed-capacity systems		4
Calculating applied forces		4
Anatomy of a crane		5 - 9
Bridge Crane Drawings		
Steel bridge crane	isometric	10
Aluminum bridge crane	isometric	11
Steel bridge crane	plan view	12
Aluminum bridge crane	plan view	13
Bridge Crane Systems & Dimensional Charts		
Installation Parameters		14
250 lb. capacity bridge cranes		15 - 17
500 lb. capacity bridge cranes		18 - 21
1000 lb. capacity bridge cranes		22 - 25
2000 lb. capacity bridge cranes		26 - 29
4000 lb. capacity bridge cranes		30 - 31
Monorails & Dimensional Information		
Monorails		32
250 lb. and 500 lb. monorails		33
1000 lb. and 2000 lb. monorails		34
4000 lb. monorail chart		35
Monorail Drawings		
Monorail	plan view	36
Monorail	isometric	37
Multiple Bridge Options		38 - 39

How to Apply Ergonomic Overhead Work Station Cranes

These questions and answers can help you determine which type of overhead work station crane best meets your needs.

What Type of Crane Is Most Appropriate?

- Bridge cranes cover rectangular areas, while jib cranes cover circular areas.
- Bridge cranes can be hung from the ceiling (see this brochure) or be floor supported (see the *Gorbel® Free-Standing Work Station Crane* brochure). Jib cranes can be wall or pillar mounted and may require a special foundation (see the *Gorbel® Work Station Jib Crane* brochure).
- An enclosed track work station bridge crane provides consistent ease of operation over the full range of movement.
- Jib cranes move more easily at the very end of the boom and are more difficult to move as the load approaches the pivot point.

Should the crane be manual or motorized?

Ease of movement and light weight are key features of enclosed track work station crane systems. In fact, manual work station cranes do the job faster than motorized cranes. If the operator cannot control the load throughout the operation (for instance, over a vat, pit, or other inaccessible area), then the crane should be motorized.

What type of suspension: ceiling mounted or free standing?

- With ceiling-mounted systems, supporting steel does not interfere with the handling operation. Ceiling-mounted systems require a building with an adequate overhead structure to hang the crane (see loading formula on page 4).
- Free-standing (floor-supported) systems do not put stress on the building's overhead structure. Installation is usually more straightforward, and these cranes are also easier to relocate in the future. These systems require a reinforced concrete floor of at least 6 inches.

What capacity, bridge length, and height?

The general rule is "less is more"

- *Keep capacities to a minimum.* Gorbel® Work Station Cranes are designed with an adequate safety factor. If you "over-buy capacity," the operator will need to move extra bridge dead weight, which would not be a good ergonomic solution.
- *Keep bridge lengths to a minimum.* The less dead weight an operator has to move, the better. Short bridge lengths are better for higher-cycle production areas. Longer bridges are acceptable for lower-production cycle or maintenance areas.
- *Keep bridge heights to a minimum.* Keeping the height less than 14 feet is desirable because it makes it easier to control and position the load.

Can the operator safely move the load?

- A work cell should be designed so a task can be performed by 90% of the workers.
- A worker should not exceed 33% of his or her capacity; otherwise, the risk of chronic fatigue increases.
- To help determine if your worker can safely move the required loads, refer to the Ergonomic Study by Shealy and Stibitz ©1993, which is available through your Gorbel® Dealer.

Enclosed Track Design Makes for Easy Movement and Long Life

Both the aluminum and steel Gorbel® Work Station Crane Systems utilize enclosed track that is high in strength and low in weight. Major advantages:

- Enclosed track cranes are easier to move than traditional bridge cranes.
- The design virtually eliminates dirt and dust from the rolling surface, thus reducing wear on the wheels of the trolley and end trucks.
- The smooth running surface means lower rolling resistance.
- The low profile of the steel track allows the system to be installed where headroom is a problem.
- The low track weight reduces the applied forces exerted on the supporting structure.
- Long spans allow systems to be installed where hanging points are infrequent (up to 30 feet with the steel truss design).
- Four distinct sizes of track -- 250, 500, 1000, and 2000 series -- enable you to keep bridge weights and costs to a minimum.

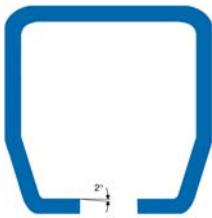

The 2° taper of the running flange helps to center the trolley in the track for smooth, effortless movement of trolleys and end trucks.



PLAIN STEEL TRACK:

For use where frequent support points are available or where maximum headroom is required.

The standard cold-rolled steel track profile offers a low-weight to high-strength ratio. Model numbers start with GLC (for bridge cranes) and GLM (for monorails).



Plain Steel Track

TRUSSED STEEL TRACK:

Permits longer spans when frequent support points are not available.

The trussed series uses the plain steel track profile but is enhanced for longer spans via a built-up truss design. This design increases the span, which decreases the need for frequent hangers. Model numbers start with: GLCS (for bridge cranes) and GLMS (for monorails) for spans up to 20 feet; GLCSL or GLMSL for spans up to 25 feet, and GLCSLX or GLMSLX for spans up to 30 feet.

Long spans translate into fewer runway support points, longer bridge lengths, and free-standing capabilities... just another reason why Gorbel® Work Station Cranes are among the most versatile to apply and easiest to install in the industry.



Trussed Steel Track

ALUMINUM TRACK:

For use where lower bridge weight and easier movement are required.

The patented shape of Gorbel's aluminum enclosed track provides for low weight, unparalleled spanning capability, and effortless movement. The low weight (up to 44% less than trussed steel track) results in easier movement, which makes for safe, productive, ergonomic work cells. Runway spans up to 20 feet and bridge lengths up to 34 feet meet a wide range of applications. Model numbers start with AL (for bridge cranes) and ALM (for monorails).



Aluminum Track

Rigid Runways Provide for Superior Positioning of Loads

Gorbel® Work Station Bridge Cranes are installed so that the runways are rigid. They do not move laterally or longitudinally. In addition, Gorbel's floating end trucks with horizontal wheels prevent binding. The combination of these design features results in unmatched ease of positioning and ease of movement. The bridge travels smoothly down the runways, and movement is unvarying along the way, no matter where a load is positioned on the bridge. This allows superior load positioning.

Another advantage of rigid runways is that they can be reinforced (Gorbel's trussed "S" series), so they are useful where long spans are required. This eliminates the need for expensive intermediate support stringers, and it lowers overall installation cost.

Mixed Capacity Bridge Crane Systems:

Reduced bridge dead weight equals better ergonomic solutions.

Mixed-capacity systems allow multiple lower capacity bridges to be used on higher capacity runways, provided the equivalent center loads (ECL) are verified at the factory to ensure that runways and hangers are not overloaded. For example, using Gorbel's mixed-capacity end trucks, four 500 lb. bridges (utilizing 500 series rail) can be hung from a 2000 lb. runway, allowing side-by-side use of *all four bridges* without overloading the system. By mixing bridges of various sizes and capacities, mixed-capacity systems offer reduced bridge dead weight, easier movement, and reduced cost.

What is meant by Rated Capacity?

The rated capacity is the live load that can be lifted by the crane system. The design load for the crane system is based on the rated capacity plus 15% for the weight of the hoist and trolley (capacity x 1.15) and an additional 25% for impact (capacity x 1.25) for a total design of capacity x 1.4 (Note, 25% impact factor is good for hoist speeds up to 50 f.p.m.). For example, a 1000 lb. Gorbel® crane allows you to pick up a 1000 lb. load, provided the hoist weighs 150 lb. or less and the hoist speed is less than 50 feet per minute.

Design load for deflection calculations is based on the rated capacity plus 15% for the weight of the hoist and trolley (capacity x 1.15). *Under no conditions should the crane be loaded beyond its rated capacity.* Gorbel® Work Station Cranes meet or exceed the ANSI B30.11 specifications for underhung bridge cranes.

Calculating Applied Forces to the Supporting Structure

This illustration shows the relative position and the direction of forces that a ceiling-mounted bridge crane applies to its supporting structure. *Before installing any crane system, it's critical that you determine whether your building will safely support the loads.*

Loads applied to the support structure can be determined using the following formulas, where:

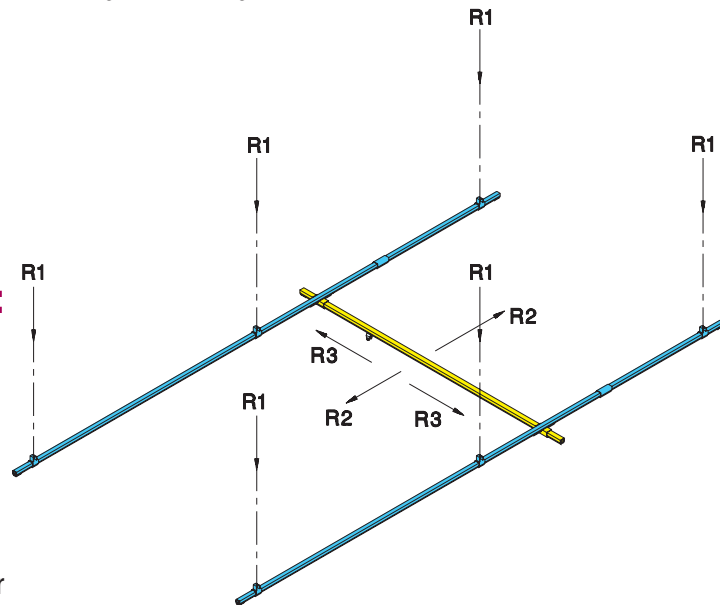

- R1 = vertical load applied by support hanger (lb.)
- R2 = longitudinal load applied by movement of the crane to each runway (lb.)
- R3 = lateral force applied by movement of the trolley and load to each runway (lb.)

- L1 = distance between support centers (ft.)
- (NOTE: If there are only 2 supports/runway, L1= L1 x 0.5)
- L4 = bridge span: center line distance between runways (ft.)
- P = live load capacity (lb.)
- 1.4 = design factor (see description below) which includes 25% for impact and 15% for assumed hoist and trolley weight

W = weight per foot of runway (lb./ft.) See page 14.

w = weight per foot of bridge (lb./ft.) See page 14.

$$R1 = 1.4 \times P + \frac{(W \times L1) + (w \times L4)}{2}$$

$$R2 = \left((1.15 \times P) + \frac{(w \times L4)}{2} \right) \times .10$$

$$R3 = 1.15 \times P \times .20$$

WARNING: Equipment described in this brochure is not designed for, and should not be used for, lifting, supporting, or transporting humans. Failure to comply with any one of the limitations noted can result in serious bodily injury and/or property damage.

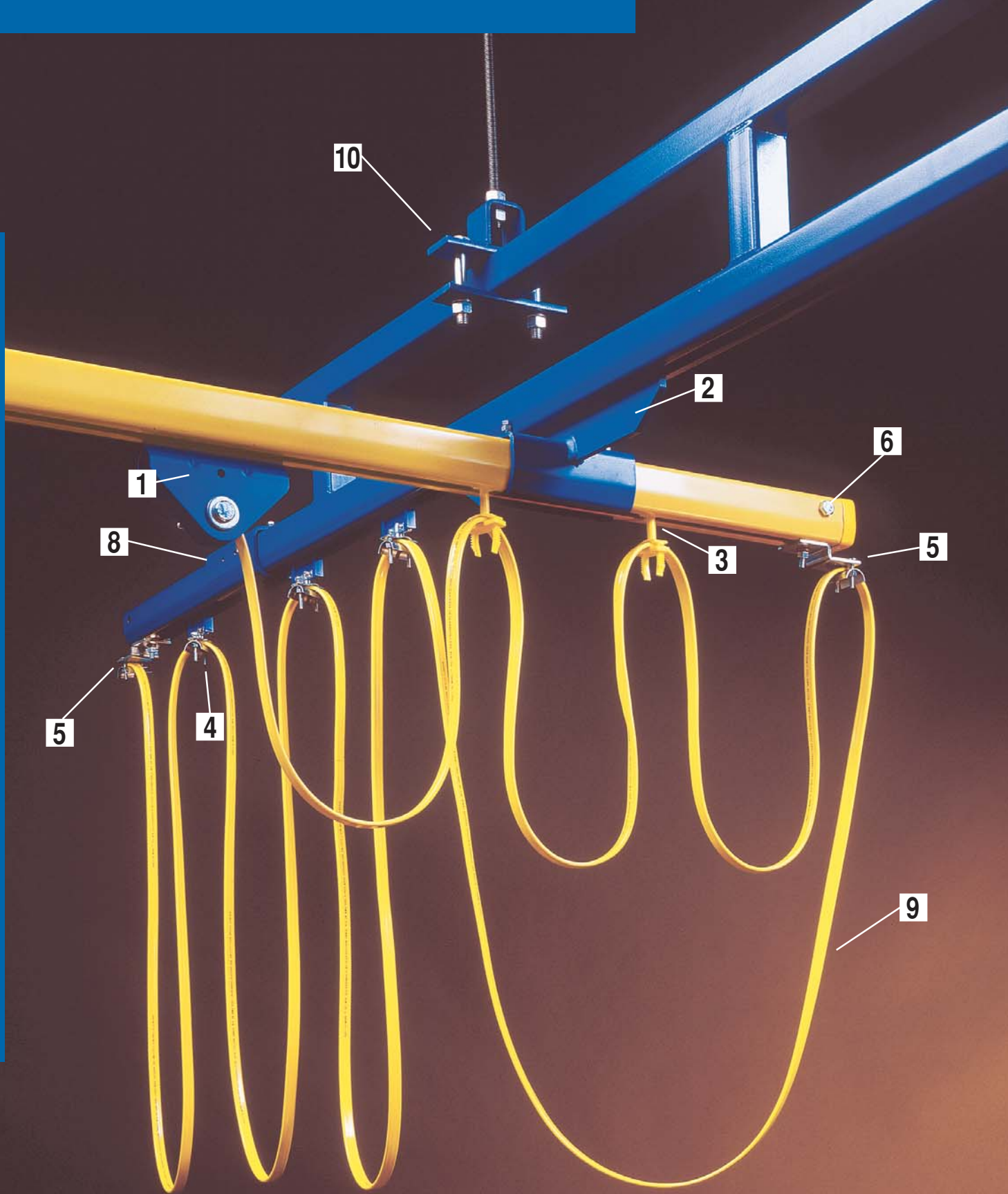

Anatomy of a Work Station Crane

1 HOIST TROLLEYS

Gorbel's hoist trolleys provide the connection between the lifting device and the bridge. The trolleys are designed for effortless movement along the bridge. The stamped body fits most rigid hook or eye lifting devices.

- Wheels are tapered to match the 2° taper of the track. This reduces rolling resistance and wheel wear. Wheels contain ball bearings that are sealed and lubricated for life.
- Trolleys are designed to operate in temperatures from +5°F to +200°F.
- All trolleys meet or exceed the ANSI B30.11 specification for underhung bridge cranes.



2 END TRUCKS

Gorbel® end trucks provide the connection between the bridge and runways. They are designed for effortless movement along the runway.

- Wheels are tapered to match the 2° taper of the track, which reduces rolling resistance and wheel wear. Wheels contain ball bearings that are sealed and lubricated for life.
- Two horizontal wheels center the end truck within the runway which prevents binding of the bridge. As a result, the position of the load on the bridge has little effect on the amount of force needed to move the bridge along the runway.
- Any slight runway track misalignment is taken up by the bridge floating in one end truck, while the other end truck is firmly clamped to the bridge.
- All end trucks meet or exceed the ANSI B30.11 specification for underhung bridge cranes.



3 FESTOON GLIDERS

Festoon gliders are used to support flat cable along the runway and bridge, and they are standard on runways of 63 feet or less. No tools are required to attach the festooning to the gliders.



4 FESTOON TROLLEYS

Gorbel® festoon trolleys (optional) are used to support flat cable or air hose along the runway or bridge. The trolleys have four wheels and a pivoting festoon saddle support. They are ideally suited for long runways (greater than 63 feet) or with round cable or air hose. With runways or monorails greater than 63 feet or with an all aluminum system, festoon trolleys are standard. Special festoon trolleys for vacuum hose are also available.



5 FESTOON CLAMPS

Festoon clamps anchor the festooning at the start of the runway and bridge. They also prevent the festoon gliders from exiting the track and they can provide a redundant stop for the end trucks and trolley.

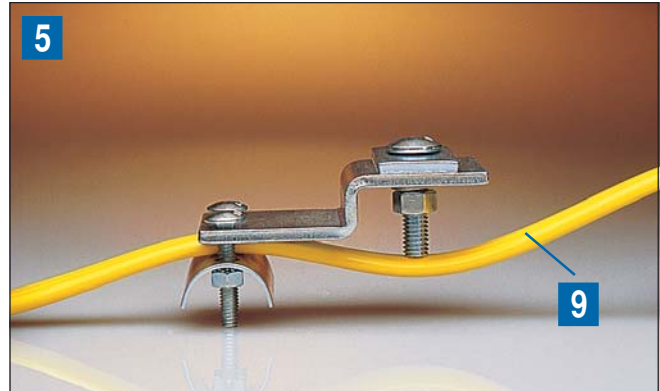

6 END STOP BUMPERS

High-impact molded end stop bumpers are provided on all runways, monorails, and bridges to prevent the end trucks and trolley from exiting the track. The bumpers are bolted to the track to physically limit the travel of the end truck and trolley.



7 UNIVERSAL BUMPERS (not shown on pg. 5)

A universal bumper can be used as a secondary end stop, either internally or externally.



8 STACK SECTIONS

A stack section at one end of a runway serves as an extension that allows festoon carriers to be stored on the end of the runway without reducing crane coverage.

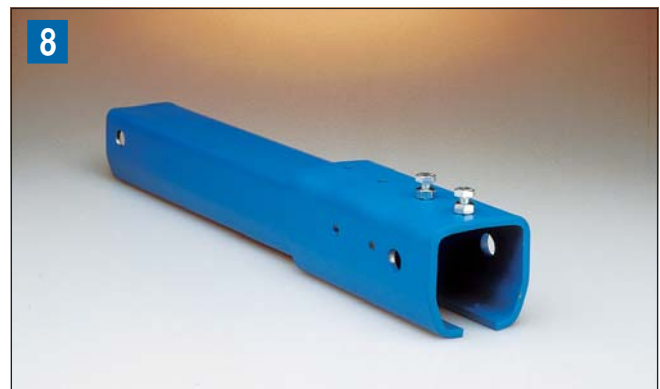

9 FLAT CABLE AND/OR AIR HOSE

A flat cable festooning system is included in all Gorbel® Work Station Bridge Cranes and monorails. Plenty of cable is provided for 3 foot loops on the runway or monorail and 1 foot 6 inch loops on the bridge.

Optional air hose is also available and is supported by optional festoon trolleys. Gorbel® Work Station Cranes can utilize optional conductor bar electrification, but this results in an increase up to 40% of the amount of effort required to move the system.

10 HANGER ASSEMBLIES

Each Gorbel® Work Station Bridge Crane or monorail is provided with the number of standard hanger assemblies listed, based on the maximum "L1" spacing shown in this brochure. Sway bracing is required on all systems, except flush-mounted systems. Sway bracing kits are not included in the crane kit (see *Sway Brace Fitting* caption on this page).

Standard Hangers for Plain Steel Track

Standard hangers for plain steel track, with a 20 inch threaded rod (B7 alloy), are included with each assembly. The threaded rod can be field cut to custom lengths as required. An optional 72 inch rod can also be supplied. Two beam clips are bolted to the upper hanger bracket and are clamped to the supporting structure. The upper hanger brackets are adjustable for flange widths from 1 to 10 inches.



Standard Hanger - Plain Steel Track

Standard Hangers for Trussed Steel Track

Standard hangers for trussed steel track, with a 20 inch threaded rod (B7 alloy), are included with each assembly. The threaded rod can be field cut to custom lengths as required. An optional 72 inch rod can also be supplied. Two beam clips are bolted to the upper hanger bracket and are clamped to the supporting structure. The upper hanger brackets are adjustable for flange widths from 1 to 10 inches.



Standard Hanger - Trussed Steel Track

Standard Hangers for Aluminum Track

Standard hangers for aluminum track, with a 20 inch threaded rod (B7 alloy), are included with each assembly. The threaded rod can be field cut to custom lengths as required. An optional 72 inch rod can also be supplied. Two beam clips are bolted to the upper hanger bracket and are clamped to the supporting structure. The upper hanger brackets are adjustable for flange widths from 1 to 10 inches.



Standard Hanger - Aluminum Track

SWAY BRACING FITTING

(not supplied as standard)

Sway bracing is required on all systems except flush mounted systems to provide for a rigid-mount runway that allows the end truck to move freely. The fittings permit easy sway bracing with 1 inch standard steel pipe (pipe supplied by others). The flange is drilled to accept a 5/8 inch bolt (bolt by others) with two U-bolts (furnished). *These optional fittings are not supplied as standard with crane kits.*



Sway Bracing Fitting

FLUSH-MOUNTED HANGERS - PARALLEL MOUNT

An optional ceiling-support bracket, with beam clips, can be provided for plain track series that require flush mounting. With this bracket, the track is mounted underneath, **parallel** to the supporting steel. Two beam clips are bolted to the hanger bracket and are clamped to the supporting structure. When using this style, care should be taken to determine if the bridge has adequate overhead clearance. *Note: to order this bracket, the flange width of the supporting structure must be supplied.*

FLUSH-MOUNTED HANGERS - PERPENDICULAR MOUNT

An optional ceiling-support bracket, with beam clips, can be provided for plain track series that require flush mounting. With this bracket, the track is mounted underneath, **perpendicular** to the supporting steel. Four beam clips are bolted to the hanger bracket and are clamped to the supporting structure. When using this style, care should be taken to determine if the bridge has adequate overhead clearance. *Note: to order this bracket, the flange width of the supporting structure must be supplied.*



Flush-Mounted Hangers - Parallel

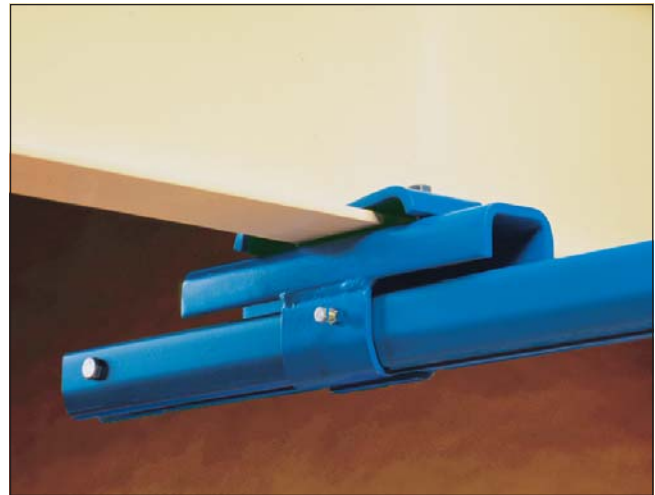

Flush-Mounted Hangers - Perpendicular

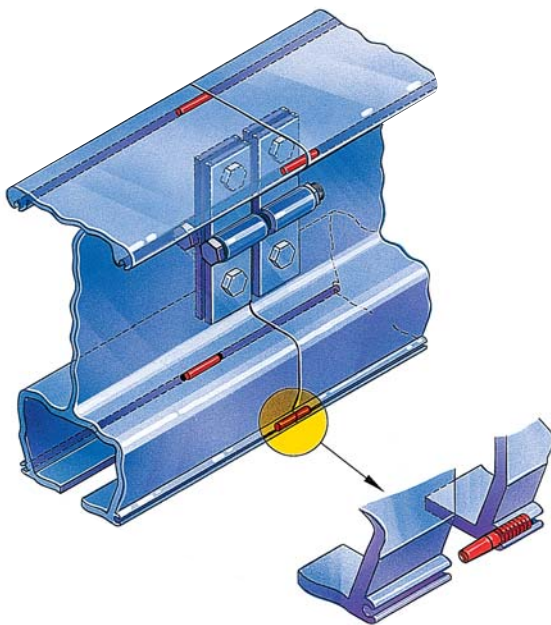

Splice Joint - Aluminum Track

SPLICE JOINTS FOR ALUMINUM TRACK

Patented splice joints for aluminum track allow for precision alignment. The aluminum track is extruded with four patented alignment slots. Four precision-ground pins are provided to accurately align runway sections, which provides for a smoother transition of wheels over the splice joint than is possible with bolted connections. In addition, clamp fasteners attach to the vertical web of the track to pull the track together and keep it from separating.

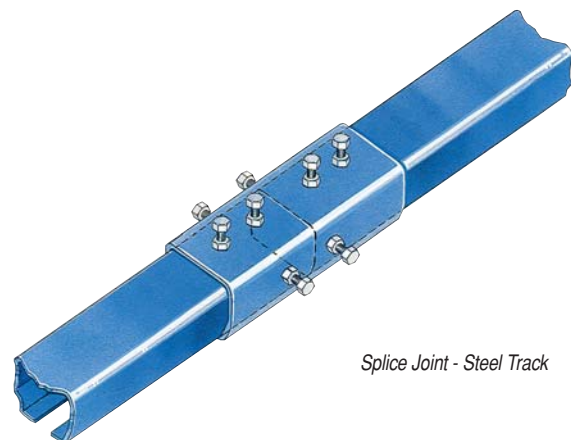

Splice Joint - Steel Track

SPLICE JOINTS FOR STEEL TRACK

A splice joint is used to join track sections together and enable the installer to quickly and properly align the joined sections of track. Adjusting bolts are provided on the splice joint for leveling and aligning.

**STEEL
CEILING MOUNTED WORK STATION BRIDGE CRANES
ISOMETRIC VIEW**

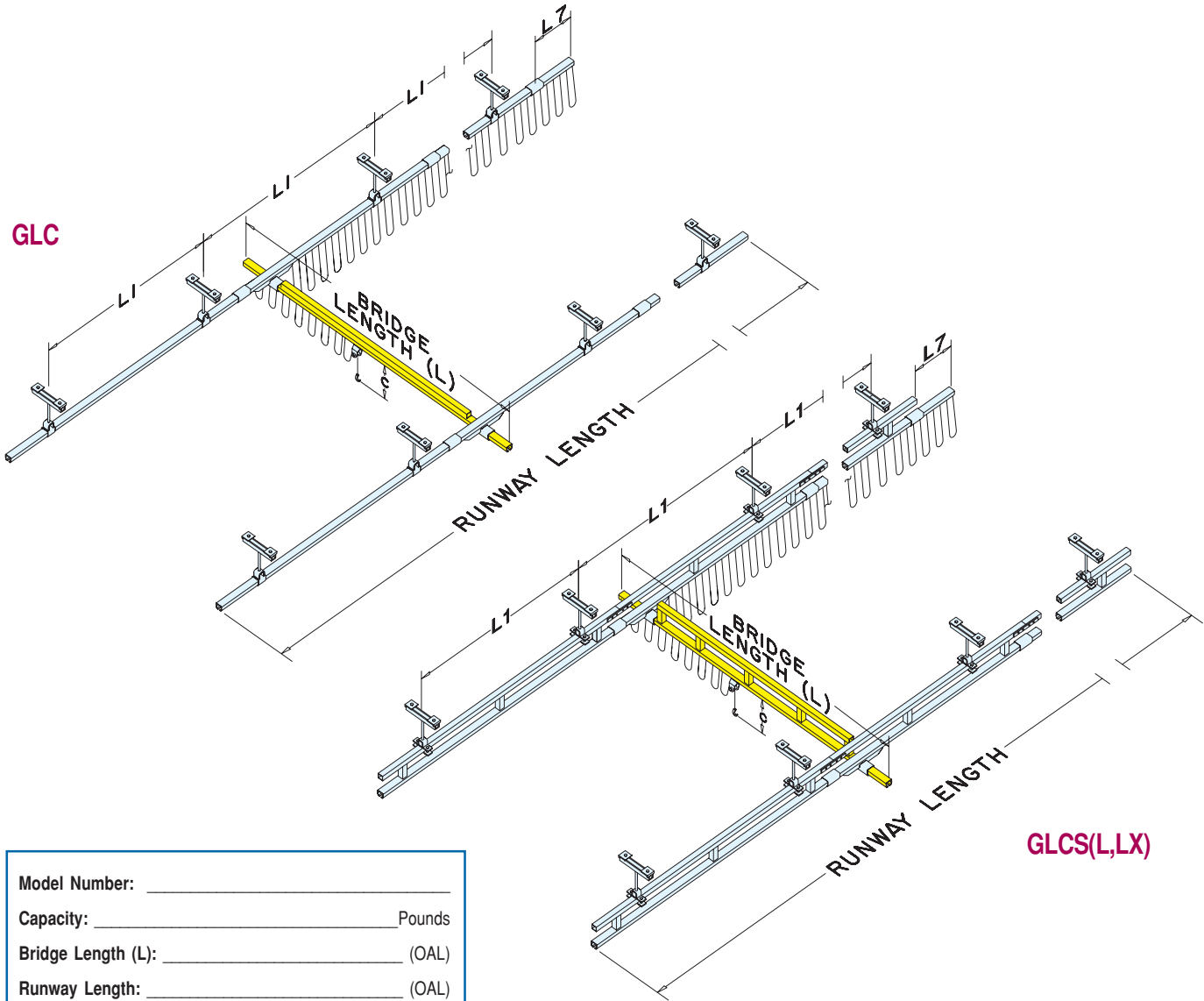

Model Number: _____

Capacity: _____ Pounds

Bridge Length (L): _____ (OAL)

Runway Length: _____ (OAL)

L1: _____ Are the number of hangers provided sufficient?
(See "HANGERS" column on dimensional chart pages.)

Type of hanger required:

- Standard hanger with up to 20 inch drop.
Support beam flange width _____ inches
- Flush mounted, parallel
Support beam flange width _____ inches
- Flush mounted, perpendicular
Support beam flange width _____ inches
- Special hangers

Note: Sway bracing is required on all systems except flush mounted systems. Sway bracing kits are available but are not included in the crane kit.

C: _____ inches (hoist by others)

Gorbel® Ceiling Mounted Bridge Cranes include: bridge, runways, hoist trolley, end trucks, end stops, flat wire festooning, festoon gliders (festoon trolleys on steel runway lengths greater than 63 feet and all aluminum systems), festoon stack-up section, splice joints and hanger brackets. Additional hanger points or longer drops, in excess of 20 inches, can be provided at an additional cost (hoist and sway bracing by others). Sway bracing kits are available but are not included in the crane kit.

Dimension and design details subject to change without notice.

**ALUMINUM
CEILING MOUNTED WORK STATION BRIDGE CRANES
ISOMETRIC VIEW**

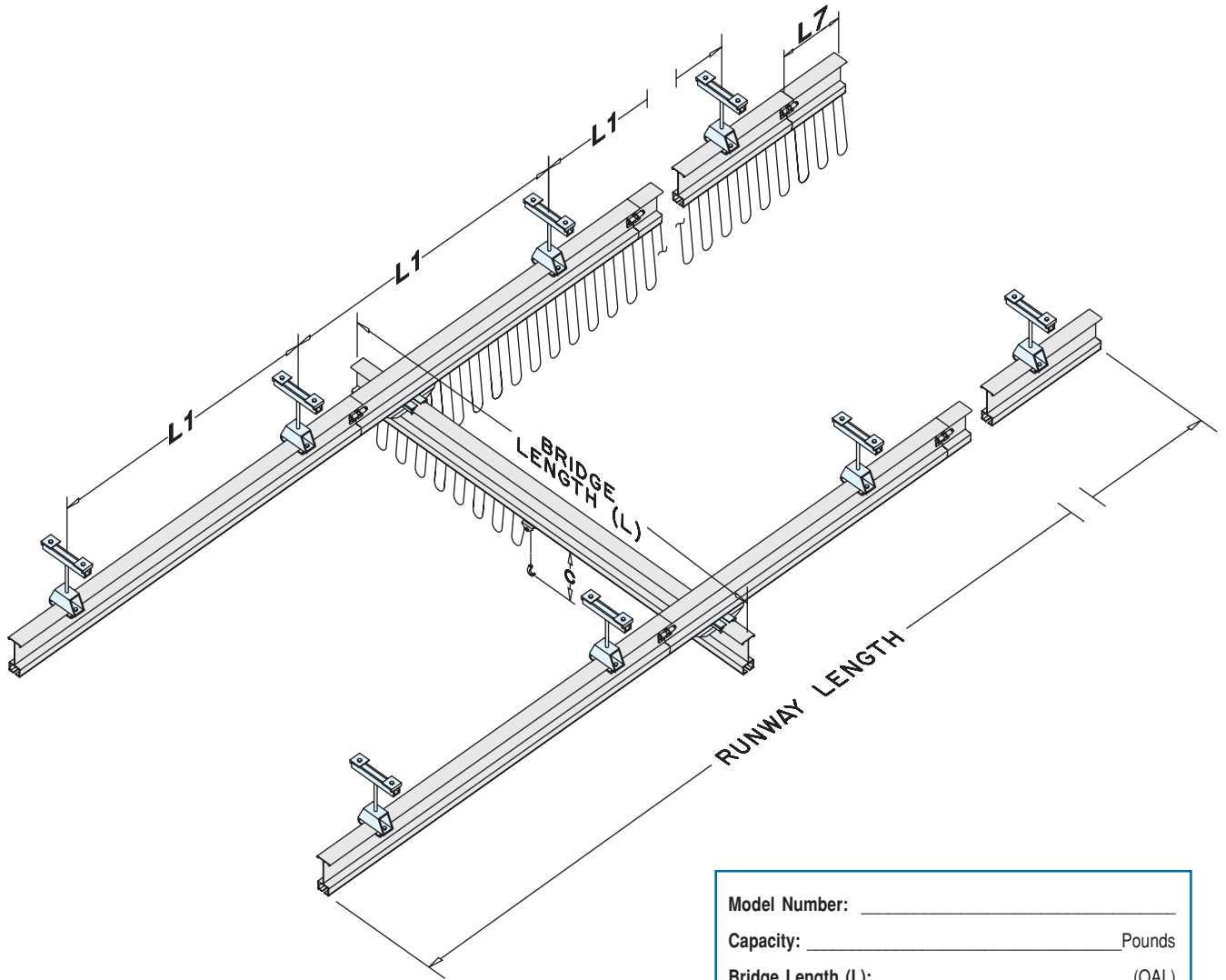

Model Number: _____

Capacity: _____ Pounds

Bridge Length (L): _____ (OAL)

Runway Length: _____ (OAL)

L1: _____ Are the number of hangers provided sufficient?

(See "HANGERS" column on dimensional chart pages.)

Type of hanger required:

- Standard hanger with up to 20 inch drop.
Support beam flange width _____ inches
- Flush mounted, parallel
Support beam flange width _____ inches
- Flush mounted, perpendicular
Support beam flange width _____ inches
- Special hangers

Note: Sway bracing is required on all systems except flush mounted systems. Sway bracing kits are available but are not included in the crane kit.

C: _____ inches (hoist by others)

Gorbel® Ceiling Mounted Bridge Cranes include: bridge, runways, hoist trolley, end trucks, end stops, flat wire festooning, festoon gliders (festoon trolleys on steel runway lengths greater than 63 feet and all aluminum systems), festoon stack-up section, splice joints and hanger brackets. Additional hanger points or longer drops, in excess of 20 inches, can be provided at an additional cost (hoist and sway bracing by others). Sway bracing kits are available but are not included in the crane kit.

Dimension and design details subject to change without notice.

STEEL CEILING MOUNTED WORK STATION BRIDGE CRANES

Model Number: _____

Capacity: _____ Pounds

Bridge Length (L): _____ (OAL)

Runway Length: _____ (OAL)

L1: _____ Are the number of hangers provided sufficient?

(See "HANGERS" column on dimensional chart pages.)

Type of hanger required:

- Standard hanger with up to 20 inch drop.
Support beam flange width _____ inches
- Flush mounted, parallel
Support beam flange width _____ inches
- Flush mounted, perpendicular
Support beam flange width _____ inches
- Special hangers

Note: Sway bracing is required on all systems except flush mounted systems. Sway bracing kits are available but are not included in the crane kit.

C: _____ inches (hoist by others)

STEEL TRACK BRIDGE ON STEEL RUNWAYS

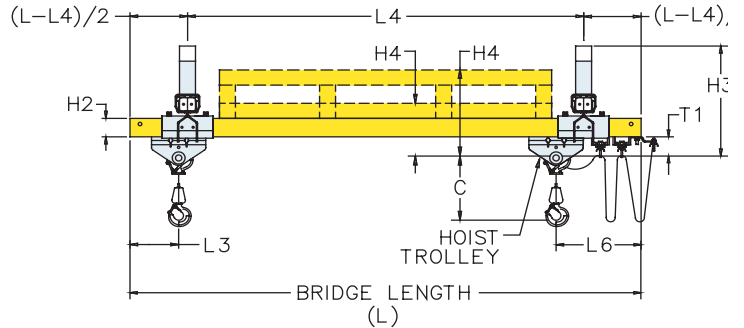

ALUMINUM TRACK BRIDGE ON STEEL RUNWAYS

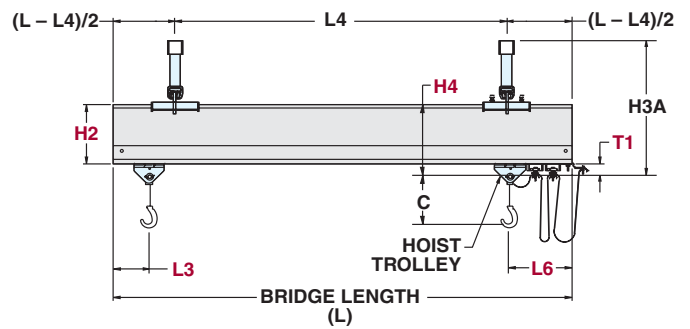

COPED ALUMINUM TRACK BRIDGE ON STEEL RUNWAYS

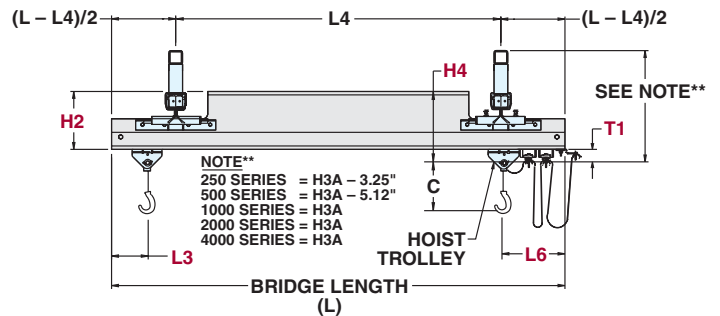

Gorbel® Ceiling Mounted Bridge Cranes include: bridge, runways, hoist trolley, end trucks, end stops, flat wire festooning, festoon gliders (festoon trolleys on steel runway lengths greater than 63 feet and all aluminum systems), festoon stack-up section, splice joints and hanger brackets. Additional hanger points or longer drops, in excess of 20 inches, can be provided at an additional cost (hoist and sway bracing by others). Sway bracing kits are available but are not included in the crane kit.

Dimension and design details subject to change without notice.

GLC STEEL RUNWAY

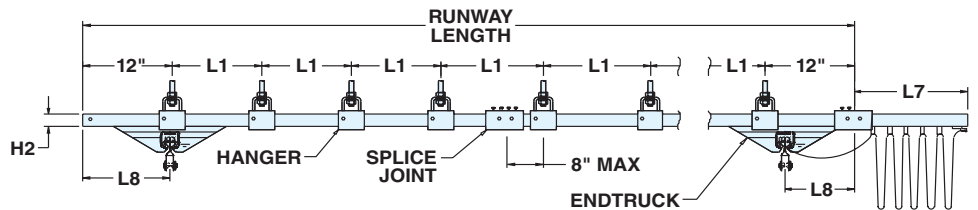

GLCS, GLCSL, GLCSLX STEEL RUNWAY

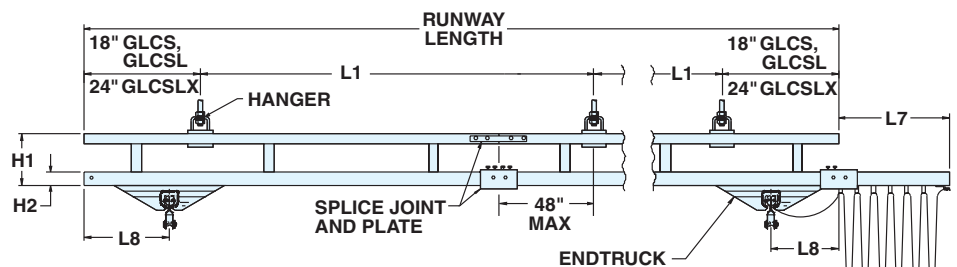

ALUMINUM CEILING MOUNTED WORK STATION BRIDGE CRANES

ALUMINUM TRACK BRIDGE ON ALUMINUM RUNWAYS

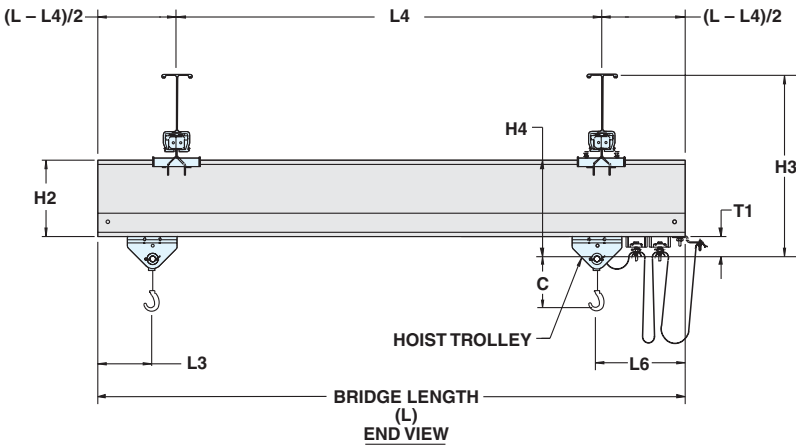

Model Number: _____

Capacity: _____ Pounds

Bridge Length (L): _____ (OAL)

Runway Length: _____ (OAL)

L1: _____ Are the number of hangers provided sufficient?

(See "HANGERS" column on dimensional chart pages.)

Type of hanger required:

- Standard hanger with up to 20 inch drop.
Support beam flange width _____ inches
- Flush mounted, parallel
Support beam flange width _____ inches
- Flush mounted, perpendicular
Support beam flange width _____ inches
- Special hangers

Note: Sway bracing is required on all systems except flush mounted systems. Sway bracing kits are available but are not included in the crane kit.

C: _____ inches (hoist by others)

COPED ALUMINUM TRACK BRIDGE ON ALUMINUM RUNWAYS

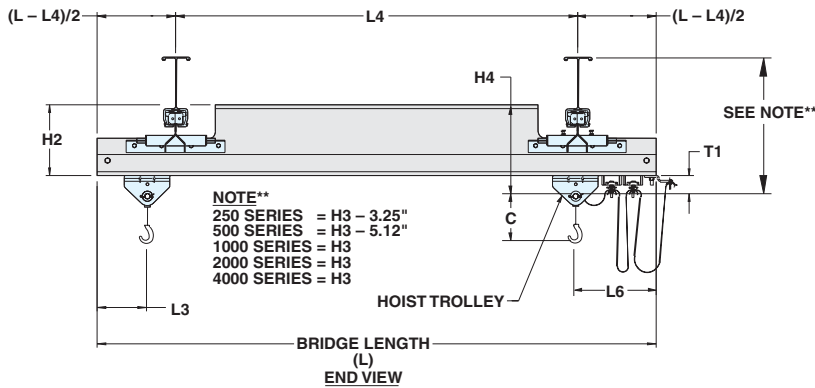

Gorbel® Ceiling Mounted Bridge Cranes include: bridge, runways, hoist trolley, end trucks, end stops, flat wire festooning, festoon gliders (festoon trolleys on steel runway lengths greater than 63 feet and all aluminum systems), festoon stack-up section, splice joints and hanger brackets. Additional hanger points or longer drops, in excess of 20 inches, can be provided at an additional cost (hoist and sway bracing by others). Sway bracing kits are available but are not included in the crane kit.

Dimension and design details subject to change without notice.

ALUMINUM RUNWAY

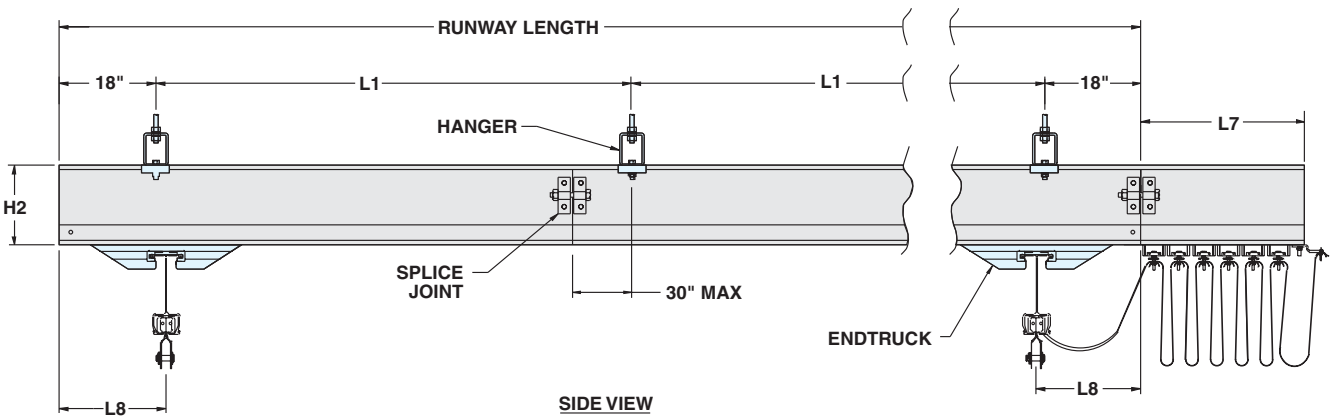

INSTALLATION GUIDELINES

CAPACITY	SERIES	WEIGHT PER FOOT	MAX. L1	MAX. L2	MAX. L5	MAX. L9
250#	GLC	2.55 #	6'	8"	18"	18"
	GLCS	4.88 #	20'	48"	18"	48"
	AL	4.00 #	20'	30"	48"	48"
	GLCSL	8.14 #	25'	48"	18"	48"
500#	GLC	4.11 #	6'	8"	24"	20"
	GLCS	7.23 #	20'	48"	24"	48"
	AL	4.70 #	20'	30"	48"	48"
	GLCSL	10.94 #	25'	48"	24"	48"
1000#	GLC	6.50 #	6'	8"	24"	20"
	GLCS	12.09 #	20'	48"	24"	48"
	AL	8.30 #	20'	30"	48"	48"
	GLCSL	13.37 #	25'	48"	24"	48"
2000#	GLC	9.00 #	6'	8"	24"	24"
	GLCS	14.59 #	20'	48"	24"	48"
	AL	10.20 #	20'	30"	48"	48"
	GLCSL	20.14 #	25'	48"	24"	48"
4000#	GLC	9.00 #	6'	8"	24"	24"
	GLCS	18.42 #	20'	48"	24"	48"
	GLCSL	23.83 #	25'	48"	24"	48"
	GLCSLX	28.02 #	30'	48"	24"	48"

L 1 = MAXIMUM HANGER CENTERLINE

Maximum Hanger Centerline is considered from the center of a hanger to the center of the neighboring hanger.

L 2 = SPLICE JOINT CENTERLINE TO HANGER CENTERLINE

Splice Joint Centerline to Hanger Centerline is considered from center of a splice joint to the center of the nearest hanger.

L 5 = BRIDGE CANTILEVER**

Bridge Cantilever is considered from the centerline of the runway to the end of the bridge.

L 9 = MAXIMUM RUNWAY CANTILEVER

Runway Cantilever is considered from the center of the end hanger to the end of the runway.

Note: Same guidelines apply for Monorails (GLMS, GLMSL, GLMSLX, ALM), with the exception of the "L5" dimension (not applicable).

Note: Typical L5 is 12". Max. L5 may not be achievable (dependent on truss design of bridge.)

Note: Anti-kick-up end trucks* are required for the following:

- bridges with $\leq 8'$ span (L4) and a bridge cantilever (L5) $\geq 12''$
- bridges with $< 10'$ span (L4) and a bridge cantilever (L5) $> 15''$
- bridges with $< 15'$ span (L4) and a bridge cantilever (L5) $> 18''$

*Anti-kick-up end trucks are not included as part of the standard crane kits.

**2000# @ 10' span (L4) and bridge cantilever (L5) 15" need anti-kick-up end trucks.

Consult Gorbel® factory for information on bridges greater than 15' span (L4).

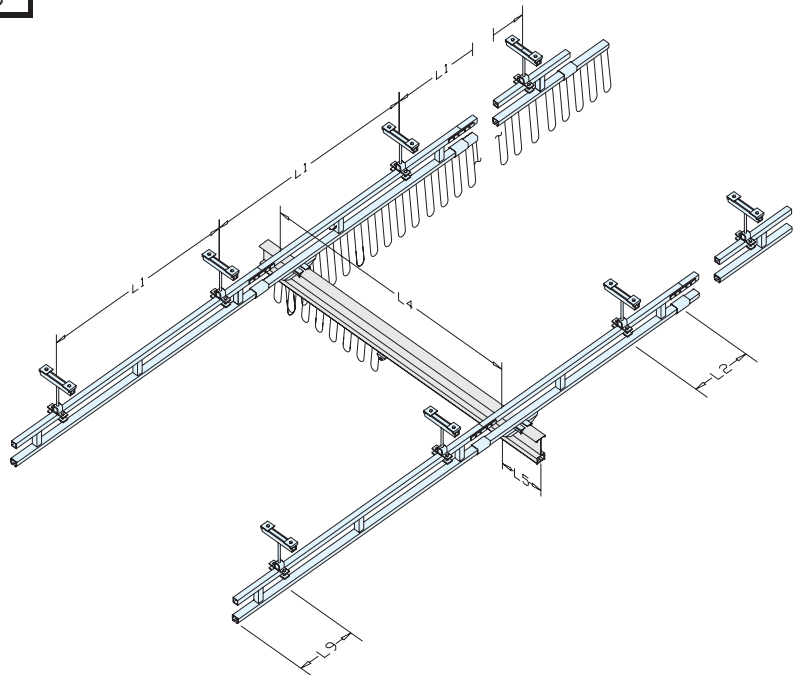

STANDARD BRIDGE CANTILEVER	Bridge Series	Bridge Overall Length				
		Steel				
		$\leq 23'$	28'	29'	33'	34'
	250	12"	18"	24"	na	na
	500	12"	18"	24"	18"	24"
	1000	12"	18"	24"	18"	24"
	2000	12"	18"	24"	18"	24"
	4000	15"	18"	24"	18"	24"

STANDARD BRIDGE CANTILEVER	Bridge Series	Bridge Overall Length					
		Aluminum					
		$\leq 20'$	23'	28'	29'	33'	34'
	250	12"	18"	18"	na	na	na
	500	12"	18"	18"	24"	18"	24"
	1000	12"	18"	18"	24"	18"	24"
	2000	12"	18"	18"	24"	18"	24"
	4000	12"	18"	18"	24"	18"	24"

CEILING MOUNTED WORK STATION BRIDGE CRANES - 250# CAPACITY

BRIDGE LENGTH (L)	RUNWAY LENGTH	MODEL NUMBER	TRACK SERIES	TRACK MATL.	MAX. L1	BRIDGE								RUNWAY				
						T1	L3	L4	L6	H3	H3A	H4	H2	H1	L7	L8	HANGERS (See Note)*	
						in	in	ft	in	in	in	in	in	in	in	in		
8'	11' 6"	GLC250-8 (S or AL)-11.5 GLCS250-8 (S or AL)-11.5 AL250-8-11.5	250 250 250	Steel Steel Alum.	6' 20' 20'	1-1/2 1-1/2 2-3/4	5 5 7-1/4	6.5' 6.5' 6.5'	7-1/2 7-1/2 13-1/2	5-5/8 12-7/8 20	13-1/2 20-3/4 -	4-3/4 4-3/4 10-3/4	1-3/4 1-3/4 8	- 9 9	9 9 9	10-3/4 10-3/4 13-1/4	6@376# 4@456# 4@447#	
	23'	GLC250-8 (S or AL)-23 GLCS250-8 (S or AL)-23 AL250-8-23	250 250 250	Steel Steel Alum.	6' 20' 20'	1-1/2 1-1/2 2-3/4	5 5 7-1/4	6.5' 6.5' 6.5'	7-1/2 7-1/2 13-1/2	5-5/8 12-7/8 20	13-1/2 20-3/4 -	4-3/4 4-3/4 10-3/4	1-3/4 1-3/4 8	- 9 8	9 9 13	10-3/4 10-3/4 13-1/4	10@376# 4@456# 4@447#	
	28'	GLCSL250-8 (S or AL)-28	250	Steel	25'	1-1/2	5	6.5'	7-1/2	14-7/8	22-3/4	4-3/4	1-3/4	11	9	10-3/4	4@564#	
	33'	GLC250-8 (S or AL)-33 GLCS250-8 (S or AL)-33 AL250-8-33	250 250 250	Steel Steel Alum.	6' 20' 20'	1-1/2 1-1/2 2-3/4	5 5 7-1/4	6.5' 6.5' 6.5'	7-1/2 7-1/2 13-1/2	5-5/8 12-7/8 20	13-1/2 20-3/4 -	4-3/4 4-3/4 10-3/4	1-3/4 1-3/4 8	- 9 8	9 9 19	10-3/4 10-3/4 13-1/4	14@376# 6@456# 6@447#	
	43'	GLC250-8 (S or AL)-43 GLCS250-8 (S or AL)-43 AL250-8-43	250 250 250	Steel Steel Alum.	6' 20' 20'	1-1/2 1-1/2 2-3/4	5 5 7-1/4	6.5' 6.5' 6.5'	7-1/2 7-1/2 13-1/2	5-5/8 12-7/8 20	13-1/2 20-3/4 -	4-3/4 4-3/4 10-3/4	1-3/4 1-3/4 8	- 9 8	13 13 26	10-3/4 10-3/4 13-1/4	18@376# 6@456# 6@447#	
	53'	GLC250-8 (S or AL)-53 GLCS250-8 (S or AL)-53 AL250-8-53 GLCSL250-8 (S or AL)-53	250 250 250 250	Steel Steel Alum. Steel	6' 20' 20' 25'	1-1/2 1-1/2 2-3/4 1-1/2	5 5 7-1/4 5	6.5' 6.5' 6.5' 6.5'	7-1/2 7-1/2 13-1/2 7-1/2	5-5/8 12-7/8 20 14-7/8	13-1/2 20-3/4 -	4-3/4 4-3/4 10-3/4 4-3/4	1-3/4 1-3/4 8 1-3/4	- 9 8 11	13 13 30 13	10-3/4 10-3/4 13-1/4 10-3/4	22@376# 8@456# 8@447# 6@564#	
	63'	GLC250-8 (S or AL)-63 GLCS250-8 (S or AL)-63 AL250-8-63	250 250 250	Steel Steel Alum.	6' 20' 20'	1-1/2 1-1/2 2-3/4	5 5 7-1/4	6.5' 6.5' 6.5'	7-1/2 7-1/2 13-1/2	5-5/8 12-7/8 20	13-1/2 20-3/4 -	4-3/4 4-3/4 10-3/4	1-3/4 1-3/4 8	- 9 8	19 19 36	10-3/4 10-3/4 13-1/4	26@376# 8@456# 8@447#	
	78'	GLCSL250-8 (S or AL)-78	250	Steel	25'	1-1/2	5	6.5'	11-3/4	14-7/8	22-3/4	4-3/4	1-3/4	11	46	10-3/4	8@564#	
	83'	GLC250-8 (S or AL)-83 GLCS250-8 (S or AL)-83 AL250-8-83	250 250 250	Steel Steel Alum.	6' 20' 20'	1-1/2 1-1/2 2-3/4	5 5 7-1/4	6.5' 6.5' 6.5'	11-3/4 11-3/4 13-1/2	5-5/8 12-7/8 20	13-1/2 20-3/4 -	4-3/4 4-3/4 10-3/4	1-3/4 1-3/4 8	- 9 8	46 46 46	10-3/4 10-3/4 13-1/4	34@376# 10@456# 10@447#	
	103'	GLC250-8 (S or AL)-103 GLCS250-8 (S or AL)-103 AL250-8-103 GLCSL250-8 (S or AL)-103	250 250 250 250	Steel Steel Alum. Steel	6' 20' 20' 25'	1-1/2 1-1/2 2-3/4 1-1/2	5 5 7-1/4 5	6.5' 6.5' 6.5' 6.5'	11-3/4 11-3/4 13-1/2 11-3/4	5-5/8 12-7/8 20 14-7/8	13-1/2 20-3/4 -	4-3/4 4-3/4 10-3/4 4-3/4	1-3/4 1-3/4 8 1-3/4	- 9 8 11	54 54 54 54	10-3/4 10-3/4 13-1/4 10-3/4	42@376# 10@456# 12@447# 10@564#	
10'	11'6"	GLC250-10 (S or AL)-11.5 GLCS250-10 (S or AL)-11.5 AL250-10-11.5	250 250 250	Steel Steel Alum.	6' 20' 20'	1-1/2 1-1/2 2-3/4	5 5 7-1/4	8' 8' 8'	8-3/4 8-3/4 16-7/8	5-5/8 12-7/8 20	13-1/2 20-3/4 -	4-3/4 4-3/4 10-3/4	1-3/4 1-3/4 8	- 9 8	9 9 9	10-3/4 10-3/4 13-1/4	6@386# 4@466# 4@451#	
	23'	GLC250-10 (S or AL)-23 GLCS250-10 (S or AL)-23 AL250-10-23	250 250 250	Steel Steel Alum.	6' 20' 20'	1-1/2 1-1/2 2-3/4	5 5 7-1/4	8' 8' 8'	8-3/4 8-3/4 16-7/8	5-5/8 12-7/8 20	13-1/2 20-3/4 -	4-3/4 4-3/4 10-3/4	1-3/4 1-3/4 8	- 9 8	9 9 13	10-3/4 10-3/4 13-1/4	10@386# 4@466# 4@451#	
	28'	GLCSL250-10 (S or AL)-28	250	Steel	25'	1-1/2	5	8'	8-3/4	14-7/8	22-3/4	4-3/4	1-3/4	11	9	10-3/4	4@574#	
	33'	GLC250-10 (S or AL)-33 GLCS250-10 (S or AL)-33 AL250-10-33	250 250 250	Steel Steel Alum.	6' 20' 20'	1-1/2 1-1/2 2-3/4	5 5 7-1/4	8' 8' 8'	8-3/4 8-3/4 16-7/8	5-5/8 12-7/8 20	13-1/2 20-3/4 -	4-3/4 4-3/4 10-3/4	1-3/4 1-3/4 8	- 9 8	9 9 19	10-3/4 10-3/4 13-1/4	14@386# 6@466# 6@451#	
	43'	GLC250-10 (S or AL)-43 GLCS250-10 (S or AL)-43 AL250-10-43	250 250 250	Steel Steel Alum.	6' 20' 20'	1-1/2 1-1/2 2-3/4	5 5 7-1/4	8' 8' 8'	8-3/4 8-3/4 16-7/8	5-5/8 12-7/8 20	13-1/2 20-3/4 -	4-3/4 4-3/4 10-3/4	1-3/4 1-3/4 8	- 9 8	13 13 26	10-3/4 10-3/4 13-1/4	18@386# 6@466# 6@451#	
	53'	GLC250-10 (S or AL)-53 GLCS250-10 (S or AL)-53 AL250-10-53 GLCSL250-10 (S or AL)-53	250 250 250 250	Steel Steel Alum. Steel	6' 20' 20' 25'	1-1/2 1-1/2 2-3/4 1-1/2	5 5 7-1/4 5	8' 8' 8' 8'	8-3/4 8-3/4 16-7/8 8-3/4	5-5/8 12-7/8 20 14-7/8	13-1/2 20-3/4 -	4-3/4 4-3/4 10-3/4 4-3/4	1-3/4 1-3/4 8 1-3/4	- 9 8 11	13 13 30 13	10-3/4 10-3/4 13-1/4 10-3/4	22@386# 8@466# 8@451# 6@574#	
	63'	GLC250-10 (S or AL)-63 GLCS250-10 (S or AL)-63 AL250-10-63	250 250 250	Steel Steel Alum.	6' 20' 20'	1-1/2 1-1/2 2-3/4	5 5 7-1/4	8' 8' 8'	8-3/4 8-3/4 16-7/8	5-5/8 12-7/8 20	13-1/2 20-3/4 -	4-3/4 4-3/4 10-3/4	1-3/4 1-3/4 8	- 9 8	19 19 36	10-3/4 10-3/4 13-1/4	26@386# 8@466# 8@451#	
	78'	GLCSL250-10 (S or AL)-78	250	Steel	25'	1-1/2	5	8'	15-1/8	14-7/8	22-3/4	4-3/4	1-3/4	11	46	10-3/4	8@574#	
	83'	GLC250-10 (S or AL)-83 GLCS250-10 (S or AL)-83 AL250-10-83	250 250 250	Steel Steel Alum.	6' 20' 20'	1-1/2 1-1/2 2-3/4	5 5 7-1/4	8' 8' 8'	15-1/8 15-1/8 16-7/8	5-5/8 12-7/8 20	13-1/2 20-3/4 -	4-3/4 4-3/4 10-3/4	1-3/4 1-3/4 8	- 9 8	46 46 46	10-3/4 10-3/4 13-1/4	34@386# 10@466# 10@451#	
	103'	GLC250-10 (S or AL)-103 GLCS250-10 (S or AL)-103 AL250-10-103 GLCSL250-10 (S or AL)-103	250 250 250 250	Steel Steel Alum. Steel	6' 20' 20' 25'	1-1/2 1-1/2 2-3/4 1-1/2	5 5 7-1/4 5	8' 8' 8' 8'	15-1/8 15-1/8 16-7/8 15-1/8	5-5/8 12-7/8 20 14-7/8	13-1/2 20-3/4 -	4-3/4 4-3/4 10-3/4 4-3/4	1-3/4 1-3/4 8 1-3/4	- 9 8 11	54 54 54 54	10-3/4 10-3/4 13-1/4 10-3/4	42@386# 12@466# 12@451# 10@574#	

*This column provides the total number of support hangers with the corresponding vertical load applied by each support hanger (in pounds) based on the "L1" dimensions shown. Up to a 20" hanger drop will be provided by Gorbel. Additional hanger points or longer drops can be provided at an additional charge.

Gorbel® Work Station Bridge Crane kits include: bridge, runways, hoist trolley, end trucks, end stops, flat wire festooning, festoon gliders (festoon trolleys on steel runway lengths greater than 63' and all aluminum systems), festoon stack-up section, splice joints and hanger brackets. Sway bracing is required on all systems except flush mounted systems (by others). Sway bracing kits are available but are not included in the crane kit.

Dimensions are for reference only and are subject to change without notice.

CEILING MOUNTED WORK STATION BRIDGE CRANES - 250# CAPACITY

BRIDGE LENGTH (L)	RUNWAY LENGTH	MODEL NUMBER	TRACK SERIES	TRACK MATL.	MAX. L1	BRIDGE								RUNWAY				
						T1	L3	L4	L6	H3	H3A	H4	H2	H1	L7	L8	HANGERS (See Note)*	
						in	in	ft	in	in	in	in	in	in	in	in		
15'	23'	GLC250-15 (S or AL)-23	250	Steel	6'	1-1/2	5	13'	11-1/4	5-5/8	13-1/2	10-1/2	1-3/4	-	9	10-3/4	10@398#	
		GLCS250-15 (S or AL)-23	250	Steel	20'	1-1/2	5	13'	11-1/4	12-7/8	20-3/4	10-1/2	1-3/4	9	9	10-3/4	4@478#	
		AL250-15-23	250	Alum.	20'	2-3/4	7-1/4	13'	23-5/8	20	-	10-3/4	8	-	13	13-1/4	4@461#	
	28'	GLCSL250-15 (S or AL)-28	250	Steel	25'	1-1/2	5	13'	11-1/4	14-7/8	22-3/4	10-1/2	1-3/4	11	9	10-3/4	4@586#	
		GLC250-15 (S or AL)-33	250	Steel	6'	1-1/2	5	13'	11-1/4	5-5/8	13-1/2	10-1/2	1-3/4	-	9	10-3/4	14@398#	
	33'	GLCS250-15 (S or AL)-33	250	Steel	20'	1-1/2	5	13'	11-1/4	12-7/8	20-3/4	10-1/2	1-3/4	9	9	10-3/4	6@478#	
		AL250-15-33	250	Alum.	20'	2-3/4	7-1/4	13'	23-5/8	20	-	10-3/4	8	-	19	13-1/4	6@461#	
	43'	GLC250-15 (S or AL)-43	250	Steel	6'	1-1/2	5	13'	11-1/4	5-5/8	13-1/2	10-1/2	1-3/4	-	13	10-3/4	18@398#	
		GLCS250-15 (S or AL)-43	250	Steel	20'	1-1/2	5	13'	11-1/4	12-7/8	20-3/4	10-1/2	1-3/4	9	13	10-3/4	6@478#	
	53'	AL250-15-43	255	Alum.	20'	2-3/4	7-1/4	13'	23-5/8	20	-	10-3/4	8	-	26	13-1/4	6@461#	
GLC250-15 (S or AL)-53		250	Steel	6'	1-1/2	5	13'	11-1/4	5-5/8	13-1/4	10-1/2	1-3/4	-	13	10-3/4	22@398#		
63'	GLCS250-15 (S or AL)-53	250	Steel	20'	1-1/2	5	13'	11-1/4	12-7/8	20-3/4	10-1/2	1-3/4	9	13	10-3/4	8@478#		
	AL250-15-53	250	Alum.	20'	2-3/4	7-1/4	13'	23-5/8	20	-	10-3/4	8	-	30	13-1/4	8@461#		
78'	GLCSL250-15 (S or AL)-53	250	Steel	25'	1-1/2	5	13'	11-1/4	14-7/8	22-3/4	10-1/2	1-3/4	11	13	10-3/4	6@586#		
	GLC250-15 (S or AL)-63	250	Steel	6'	1-1/2	5	13'	11-1/4	5-5/8	13-1/2	10-1/2	1-3/4	-	19	10-3/4	26@398#		
83'	GLCS250-15 (S or AL)-63	250	Steel	20'	1-1/2	5	13'	11-1/4	12-7/8	20-3/4	10-1/2	1-3/4	9	19	10-3/4	6@478#		
	AL250-15-63	250	Alum.	20'	2-3/4	7-1/4	13'	23-5/8	20	-	10-3/4	8	-	36	13-1/4	8@461#		
103'	GLCSL250-15 (S or AL)-78	250	Steel	25'	1-1/2	5	13'	21-7/8	14-7/8	22-3/4	10-1/2	1-3/4	11	46	10-3/4	8@586#		
	GLC250-15 (S or AL)-83	250	Steel	6'	1-1/2	5	13'	21-7/8	5-5/8	13-1/2	10-1/2	1-3/4	-	46	10-3/4	34@398#		
103'	GLCS250-15 (S or AL)-83	250	Steel	20'	1-1/2	5	13'	21-7/8	12-7/8	20-3/4	10-1/2	1-3/4	9	46	10-3/4	10@478#		
	AL250-15-83	250	Alum.	20'	2-3/4	7-1/4	13'	23-5/8	20	-	10-3/4	8	-	46	13-1/4	10@461#		
103'	GLC250-15 (S or AL)-103	250	Steel	6'	1-1/2	5	13'	21-7/8	5-5/8	13-1/2	10-1/2	1-3/4	-	54	10-3/4	42@398#		
	GLCS250-15 (S or AL)-103	250	Steel	20'	1-1/2	5	13'	21-7/8	12-7/8	20-3/4	10-1/2	1-3/4	9	54	10-3/4	12@478#		
103'	AL250-15-103	250	Alum.	20'	2-3/4	7-1/4	13'	23-5/8	20	-	10-3/4	8	-	54	13-1/4	12@461#		
	GLCSL250-15 (S or AL)-103	250	Steel	25'	1-1/2	5	13'	21-7/8	14-7/8	22-3/4	10-1/2	1-3/4	11	54	10-3/4	10@586#		
20'	23'	GLC250-20 (S or AL)-23	250	Steel	6'	1-1/2	5	18'	19-1/2	5-5/8	13-1/2	10-1/2	1-3/4	-	9	10-3/4	10@410#	
		GLCS250-20 (S or AL)-23	250	Steel	20'	1-1/2	5	18'	19-1/2	12-7/8	20-3/4	10-1/2	1-3/4	9	9	10-3/4	4@490#	
		AL250-20-23	250	Alum.	20'	2-3/4	7-1/4	18'	27	20	-	10-3/4	8	-	13	13-1/4	4@471#	
	28'	GLCSL250-20 (S or AL)-28	250	Steel	25'	1-1/2	5	18'	19-1/2	14-7/8	22-3/4	10-1/2	1-3/4	11	9	10-3/4	4@598#	
		GLC250-20 (S or AL)-33	250	Steel	6'	1-1/2	5	18'	19-1/2	5-5/8	13-1/2	10-1/2	1-3/4	-	9	10-3/4	14@410#	
	33'	GLCS250-20 (S or AL)-33	250	Steel	20'	1-1/2	5	18'	19-1/2	12-7/8	20-3/4	10-1/2	1-3/4	9	9	10-3/4	6@490#	
		AL250-20-33	250	Alum.	20'	2-3/4	7-1/4	18'	27	20	-	10-3/4	8	-	19	13-1/4	6@471#	
	43'	GLC250-20 (S or AL)-43	250	Steel	6'	1-1/2	5	18'	19-1/2	5-5/8	13-1/2	10-1/2	1-3/4	-	13	10-3/4	18@410#	
		GLCS250-20 (S or AL)-43	250	Steel	20'	1-1/2	5	18'	19-1/2	12-7/8	20-3/4	10-1/2	1-3/4	9	13	10-3/4	6@490#	
	53'	AL250-20-43	250	Alum.	20'	2-3/4	7-1/4	18'	27	20	-	10-3/4	8	-	26	13-1/4	6@471#	
GLC250-20 (S or AL)-53		250	Steel	6'	1-1/2	5	18'	19-1/2	5-5/8	13-1/2	10-1/2	1-3/4	-	13	10-3/4	22@410#		
63'	GLCS250-20 (S or AL)-53	250	Steel	20'	1-1/2	5	18'	19-1/2	12-7/8	20-3/4	10-1/2	1-3/4	9	13	10-3/4	8@490#		
	AL250-20-53	250	Alum.	20'	2-3/4	7-1/4	18'	27	20	-	10-3/4	8	-	30	13-1/4	8@471#		
78'	GLCSL250-20 (S or AL)-53	250	Steel	25'	1-1/2	5	18'	19-1/2	14-7/8	22-3/4	10-1/2	1-3/4	11	13	10-3/4	6@598#		
	GLC250-20 (S or AL)-63	250	Steel	6'	1-1/2	5	18'	19-1/2	5-5/8	13-1/2	10-1/2	1-3/4	-	19	10-3/4	26@410#		
83'	GLCS250-20 (S or AL)-63	250	Steel	20'	1-1/2	5	18'	19-1/2	12-7/8	20-3/4	10-1/2	1-3/4	9	19	10-3/4	8@490#		
	AL250-20-63	250	Alum.	20'	2-3/4	7-1/4	18'	27	20	-	10-3/4	8	-	36	13-1/4	8@471#		
103'	GLCSL250-20 (S or AL)-78	250	Steel	25'	1-1/2	5	18'	25-1/4	14-7/8	22-3/4	10-1/2	1-3/4	11	46	10-3/4	8@598#		
	GLC250-20 (S or AL)-83	250	Steel	6'	1-1/2	5	18'	25-1/4	5-5/8	13-1/2	10-1/2	1-3/4	-	46	10-3/4	34@410#		
103'	GLCS250-20 (S or AL)-83	250	Steel	20'	1-1/2	5	18'	25-1/4	12-7/8	20-3/4	10-1/2	1-3/4	9	46	10-3/4	10@490#		
	AL250-20-83	250	Alum.	20'	2-3/4	7-1/4	18'	27	20	-	10-3/4	8	-	46	13-1/4	10@471#		
103'	GLC250-20 (S or AL)-103	250	Steel	6'	1-1/2	5	18'	25-1/4	5-5/8	13-1/2	10-1/2	1-3/4	-	54	10-3/4	42@410#		
	GLCS250-20 (S or AL)-103	250	Steel	20'	1-1/2	5	18'	25-1/4	12-7/8	20-3/4	10-1/2	1-3/4	9	54	10-3/4	12@490#		
103'	AL250-20-103	250	Alum.	20'	2-3/4	7-1/4	18'	27	20	-	10-3/4	8	-	54	13-1/4	12@471#		
	GLCSL250-20 (S or AL)-103	250	Steel	25'	1-1/2	5	18'	25-1/4	14-7/8	22-3/4	10-1/2	1-3/4	11	54	10-3/4	10@598#		

*This column provides the total number of support hangers with the corresponding vertical load applied by each support hanger (in pounds) based on the "L1" dimensions shown. Up to a 20" hanger drop will be provided by Gorbel. Additional hanger points or longer drops can be provided at an additional charge.

Gorbel® Work Station Bridge Crane kits include: bridge, runways, hoist trolley, end trucks, end stops, flat wire festooning, festoon gliders (festoon trolleys on steel runway lengths greater than 63' and all aluminum systems), festoon stack-up section, splice joints and hanger brackets. Sway bracing is required on all systems except flush mounted systems (by others). Sway bracing kits are available but are not included in the crane kit.

Dimensions are for reference only and are subject to change without notice.

CEILING MOUNTED WORK STATION BRIDGE CRANES - 250# CAPACITY

BRIDGE LENGTH (L)	RUNWAY LENGTH	MODEL NUMBER	TRACK SERIES	TRACK MATL.	MAX. L1	BRIDGE								RUNWAY			
						T1	L3	L4	L6	H3	H3A	H4	H2	H1	L7	L8	HANGERS
						in	in	ft	in	in	in	in	in	in	in	in	in
23'	23'	GLC250-23 (S or AL)-23	250	Steel	6'	1-1/2	5	21'	19-1/2	5-5/8	13-1/2	10-1/2	1-3/4	-	9	10-3/4	10@417#
		GLCS250-23 (S or AL)-23	250	Steel	20'	1-1/2	5	21'	19-1/2	12-7/8	20-3/4	10-1/2	1-3/4	9	9	10-3/4	4@497#
		AL250-23-23	250	Alum.	20'	2-3/4	7-1/4	20'	30-3/8	20	-	10-3/4	8	-	13	13-1/4	4@477#
	28'	GLCSL250-23 (S or AL)-28	250	Steel	25'	1-1/2	5	21'	19-1/2	14-7/8	22-3/4	10-1/2	1-3/4	11	9	10-3/4	4@605#
		GLC250-23 (S or AL)-33	250	Steel	6'	1-1/2	5	21'	19-1/2	5-5/8	13-1/2	10-1/2	1-3/4	-	9	10-3/4	14@417#
		GLCS250-23 (S or AL)-33	250	Steel	20'	1-1/2	5	21'	19-1/2	12-7/8	20-3/4	10-1/2	1-3/4	9	9	10-3/4	6@497#
	AL250-23-33	250	Alum.	20'	2-3/4	7-1/4	20'	30-3/8	20	-	10-3/4	8	-	19	13-1/4	6@477#	
	43'	GLC250-23 (S or AL)-43	250	Steel	6'	1-1/2	5	21'	19-1/2	5-5/8	13-1/2	10-1/2	1-3/4	-	13	10-3/4	18@417#
		GLCS250-23 (S or AL)-43	250	Steel	20'	1-1/2	5	21'	19-1/2	12-7/8	20-3/4	10-1/2	1-3/4	9	13	10-3/4	6@497#
		AL250-23-43	250	Alum.	20'	2-3/4	7-1/4	20'	30-3/8	20	-	10-3/4	8	-	26	13-1/4	6@477#
53'	GLC250-23 (S or AL)-53	250	Steel	6'	1-1/2	5	21'	19-1/2	5-5/8	13-1/2	10-1/2	1-3/4	-	13	10-3/4	22@417#	
	GLCS250-23 (S or AL)-53	250	Steel	20'	1-1/2	5	21'	19-1/2	12-7/8	20-3/4	10-1/2	1-3/4	9	13	10-3/4	8@497#	
	AL250-23-53	250	Alum.	20'	2-3/4	7-1/4	20'	30-3/8	20	-	10-3/4	8	-	30	13-1/4	8@477#	
	GLCSL250-23 (S or AL)-53	250	Steel	25'	1-1/2	5	21'	19-1/2	14-7/8	22-3/4	10-1/2	1-3/4	11	13	10-3/4	6@605#	
63'	GLC250-23 (S or AL)-63	250	Steel	6'	1-1/2	5	21'	19-1/2	5-5/8	13-1/2	10-1/2	1-3/4	-	19	10-3/4	26@417#	
	GLCS250-23 (S or AL)-63	250	Steel	20'	1-1/2	5	21'	19-1/2	12-7/8	20-3/4	10-1/2	1-3/4	9	19	10-3/4	8@497#	
	AL250-23-63	250	Alum.	20'	2-3/4	7-1/4	20'	30-3/8	20	-	10-3/4	8	-	36	13-1/4	8@477#	
78'	GLCSL250-23 (S or AL)-78	250	Steel	25'	1-1/2	5	21'	28-5/8	14-7/8	22-3/4	10-1/2	1-3/4	11	46	10-3/4	8@605#	
83'	GLC250-23 (S or AL)-83	250	Steel	6'	1-1/2	5	21'	28-5/8	5-5/8	13-1/2	10-1/2	1-3/4	-	46	10-3/4	34@417#	
	GLCS250-23 (S or AL)-83	250	Steel	20'	1-1/2	5	21'	28-5/8	12-7/8	20-3/4	10-1/2	1-3/4	9	46	10-3/4	10@497#	
	AL250-23-83	250	Alum.	20'	2-3/4	7-1/4	20'	30-3/8	20	-	10-3/4	8	-	46	13-1/4	10@477#	
103'	GLC250-23 (S or AL)-103	250	Steel	6'	1-1/2	5	21'	28-5/8	5-5/8	13-1/2	10-1/2	1-3/4	-	54	10-3/4	42@417#	
	GLCS250-23 (S or AL)-103	250	Steel	20'	1-1/2	5	21'	28-5/8	12-7/8	20-3/4	10-1/2	1-3/4	9	54	10-3/4	12@497#	
	AL250-23-103	250	Alum.	20'	2-3/4	7-1/4	20'	30-3/8	20	-	10-3/4	8	-	54	13-1/4	12@477#	
	GLCSL250-23 (S or AL)-103	250	Steel	25'	1-1/2	5	21'	28-5/8	14-7/8	22-3/4	10-1/2	1-3/4	11	54	10-3/4	10@605#	
28'	23'	GLC250-28 (S or AL)-23	250	Steel	6'	1-1/2	5	25'	28-1/2	8	18-1/8	12-1/2	1-3/4	-	9	21-3/4	10@465#
		GLCS250-28 (S or AL)-23	250	Steel	20'	1-1/2	5	25'	28-1/2	15-1/4	25-3/8	12-1/2	1-3/4	9	9	21-3/4	4@546#
		AL250-28-23	250	Alum.	20'	2-3/4	7-1/4	25'	37-1/8	24-3/8	-	12-3/4	10	-	13	23-3/8	4@477#
	28'	GLCSL250-28 (S or AL)-28	250	Steel	25'	1-1/2	5	25'	28-1/2	17-1/4	27-3/8	12-1/2	1-3/4	11	9	21-3/4	4@653#
		GLC250-28 (S or AL)-33	250	Steel	6'	1-1/2	5	25'	28-1/2	8	18-1/8	12-1/2	1-3/4	-	9	21-3/4	14@465#
		GLCS250-28 (S or AL)-33	250	Steel	20'	1-1/2	5	25'	28-1/2	15-1/4	25-3/8	12-1/2	1-3/4	9	9	21-3/4	6@546#
	AL250-28-33	250	Alum.	20'	2-3/4	7-1/4	25'	37-1/8	24-3/8	-	12-3/4	10	-	19	23-3/8	6@477#	
	43'	GLC250-28 (S or AL)-43	250	Steel	6'	1-1/2	5	25'	28-1/2	8	18-1/8	12-1/2	1-3/4	-	13	21-3/4	18@465#
		GLCS250-28 (S or AL)-43	250	Steel	20'	1-1/2	5	25'	28-1/2	15-1/4	25-3/8	12-1/2	1-3/4	9	13	21-3/4	6@546#
		AL250-28-43	250	Alum.	20'	2-3/4	7-1/4	25'	37-1/8	24-3/8	-	12-3/4	10	-	26	23-3/8	6@477#
53'	GLC250-28 (S or AL)-53	250	Steel	6'	1-1/2	5	25'	28-1/2	8	18-1/8	12-1/2	1-3/4	-	13	21-3/4	22@465#	
	GLCS250-28 (S or AL)-53	250	Steel	20'	1-1/2	5	25'	28-1/2	15-1/4	25-3/8	12-1/2	1-3/4	9	13	21-3/4	8@546#	
	AL250-28-53	250	Alum.	20'	2-3/4	7-1/4	25'	37-1/8	24-3/8	-	12-3/4	10	-	30	23-3/8	8@477#	
	GLCSL250-28 (S or AL)-53	250	Steel	25'	1-1/2	5	25'	28-1/2	17-1/4	27-3/8	12-1/2	1-3/4	11	13	21-3/4	6@653#	
63'	GLC250-28 (S or AL)-63	250	Steel	6'	1-1/2	5	25'	28-1/2	8	18-1/8	12-1/2	1-3/4	-	19	21-3/4	26@465#	
	GLCS250-28 (S or AL)-63	250	Steel	20'	1-1/2	5	25'	28-1/2	15-1/4	25-3/8	12-1/2	1-3/4	9	19	21-3/4	8@546#	
	AL250-28-63	250	Alum.	20'	2-3/4	7-1/4	25'	37-1/8	24-3/8	-	12-3/4	10	-	36	23-3/8	8@477#	
78'	GLCSL250-28 (S or AL)-78	250	Steel	25'	1-1/2	5	25'	35-3/8	17-1/4	27-3/8	12-1/2	1-3/4	11	46	21-3/4	8@653#	
83'	GLC250-28 (S or AL)-83	250	Steel	6'	1-1/2	5	25'	35-3/8	8	18-1/8	12-1/2	1-3/4	-	46	21-3/4	34@465#	
	GLCS250-28 (S or AL)-83	250	Steel	20'	1-1/2	5	25'	35-3/8	15-1/4	25-3/8	12-1/2	1-3/4	9	46	21-3/4	10@546#	
	AL250-28-83	250	Alum.	20'	2-3/4	7-1/4	25'	37-1/8	24-3/8	-	12-3/4	10	-	46	23-3/8	10@477#	
103'	GLC250-28 (S or AL)-103	250	Steel	6'	1-1/2	5	25'	35-3/8	8	18-1/8	12-1/2	1-3/4	-	54	21-3/4	42@465#	
	GLCS250-28 (S or AL)-103	250	Steel	20'	1-1/2	5	25'	35-3/8	15-1/4	25-3/8	12-1/2	1-3/4	9	54	21-3/4	12@546#	
	AL250-28-103	250	Alum.	20'	2-3/4	7-1/4	25'	37-1/8	24-3/8	-	12-3/4	10	-	54	23-3/8	12@477#	
	GLCSL250-28 (S or AL)-103	250	Steel	25'	1-1/2	5	25'	35-3/8	17-1/4	27-3/8	12-1/2	1-3/4	11	54	21-3/4	10@653#	

*This column provides the total number of support hangers with the corresponding vertical load applied by each support hanger (in pounds) based on the "L1" dimensions shown. Up to a 20" hanger drop will be provided by Gorbel. Additional hanger points or longer drops can be provided at an additional charge.

Gorbel® Work Station Bridge Crane kits include: bridge, runways, hoist trolley, end trucks, end stops, flat wire festooning, festoon gliders (festoon trolleys on steel runway lengths greater than 63' and all aluminum systems), festoon stack-up section, splice joints and hanger brackets. Sway bracing is required on all systems except flush mounted systems (by others). Sway bracing kits are available but are not included in the crane kit.

Dimensions are for reference only and are subject to change without notice.

CEILING MOUNTED WORK STATION BRIDGE CRANES - 500# CAPACITY

BRIDGE LENGTH (L)	RUNWAY LENGTH	MODEL NUMBER	TRACK SERIES	TRACK MATL.	MAX. L1	BRIDGE										RUNWAY			
						T1	L3	L4	L6	H3	H3A	H4	H2	H1	L7	L8	HANGERS (See Note)*		
						in	in	ft	in	in	in	in	in	in	in	in			
8'	11' 6"	GLC500-8 (S or AL)-11.5 GLCS500-8 (S or AL)-11.5 AL500-8-11.5	500 500 500	Steel Steel Alum.	6' 20' 20'	2-3/4 2-3/4 2-5/8	7-1/8 7-1/8 7-1/4	6.5' 6.5' 6.5'	9-1/4 9-1/4 13-1/2	9 16-5/8 23-7/8	16-3/8 24 -	6-3/4 6-3/4 12-5/8	2-3/8 2-3/8 10	- 10 9	9 9 9	13-1/8 13-1/8 13-1/4	6@741# 4@861# 4@814#		
	23'	GLC500-8 (S or AL)-23 GLCS500-8 (S or AL)-23 AL500-8-23	500 500 500	Steel Steel Alum.	6' 20' 20'	2-3/4 2-3/4 2-5/8	7-1/8 7-1/8 7-1/4	6.5' 6.5' 6.5'	9-1/4 9-1/4 13-1/2	9 16-5/8 23-7/8	16-3/8 24 -	6-3/4 6-3/4 12-5/8	2-3/8 2-3/8 10	- 10 13	9 9 13	13-1/8 13-1/8 13-1/4	10@741# 4@861# 4@814#		
	28'	GLCSL500-8 (S or AL)-28	500	Steel	25'	2-3/4	7-1/8	6.5'	9-1/4	19	26-3/8	6-3/4	2-3/8	12-3/8	9	13-1/8	4@959#		
	33'	GLC500-8 (S or AL)-33 GLCS500-8 (S or AL)-33 AL500-8-33	500 500 500	Steel Steel Alum.	6' 20' 20'	2-3/4 2-3/4 2-5/8	7-1/8 7-1/8 7-1/4	6.5' 6.5' 6.5'	9-1/4 9-1/4 13-1/2	9 16-5/8 23-7/8	16-3/8 24 -	6-3/4 6-3/4 12-5/8	2-3/8 2-3/8 10	- 10 19	9 9 19	13-1/8 13-1/8 13-1/4	14@741# 6@861# 6@814#		
	34'	GLCSLX500-8 (S or AL)-34	500	Steel	30'	2-3/4	7-1/8	6.5'	9-1/4	21	28-3/8	6-3/4	2-3/8	14-3/8	9	13-1/8	4@1,007#		
	43'	GLC500-8 (S or AL)-43 GLCS500-8 (S or AL)-43 AL500-8-43	500 500 500	Steel Steel Alum.	6' 20' 20'	2-3/4 2-3/4 2-5/8	7-1/8 7-1/8 7-1/4	6.5' 6.5' 6.5'	9-1/4 9-1/4 13-1/2	9 16-5/8 23-7/8	16-3/8 24 -	6-3/4 6-3/4 12-5/8	2-3/8 2-3/8 10	- 10 13	13 13 26	13-1/8 13-1/8 13-1/4	18@741# 6@861# 6@814#		
	53'	GLC500-8 (S or AL)-53 GLCS500-8 (S or AL)-53 AL500-8-53 GLCSL500-8 (S or AL)-53	500 500 500 500	Steel Steel Alum. Steel	6' 20' 20' 25'	2-3/4 2-3/4 2-5/8 2-3/4	7-1/8 7-1/8 7-1/4 7-1/8	6.5' 6.5' 6.5' 6.5'	9-1/4 9-1/4 13-1/2 9-1/4	9 16-5/8 23-7/8 19	16-3/8 24 -	6-3/4 6-3/4 12-5/8 6-3/4	2-3/8 2-3/8 10 2-3/8	- 10 13 12-3/8	13 13 30 13	13-1/8 13-1/8 13-1/4 13-1/8	22@741# 8@861# 8@814# 6@959#		
	63'	GLC500-8 (S or AL)-63 GLCS500-8 (S or AL)-63 AL500-8-63	500 500 500	Steel Steel Alum.	6' 20' 20'	2-3/4 2-3/4 2-5/8	7-1/8 7-1/8 7-1/4	6.5' 6.5' 6.5'	9-1/4 9-1/4 13-1/2	9 16-5/8 23-7/8	16-3/8 24 -	6-3/4 6-3/4 12-5/8	2-3/8 2-3/8 10	- 10 19	19 19 36	13-1/8 13-1/8 13-1/4	26@741# 8@861# 8@814#		
	64'	GLCSLX500-8 (S or AL)-64	500	Steel	30'	2-3/4	7-1/8	6.5'	13-1/2	21	28-3/8	6-3/4	2-3/8	14-3/8	36	13-1/8	6@1,007#		
	78'	GLCSL500-8 (S or AL)-78	500	Steel	25'	2-3/4	7-1/8	6.5'	13-1/2	19	26-3/8	6-3/4	2-3/8	12-3/8	46	13-1/8	8@959#		
	83'	GLC500-8 (S or AL)-83 GLCS500-8 (S or AL)-83 AL500-8-83	500 500 500	Steel Steel Alum.	6' 20' 20'	2-3/4 2-3/4 2-5/8	7-1/8 7-1/8 7-1/4	6.5' 6.5' 6.5'	13-1/2 13-1/2 13-1/2	9 16-5/8 23-7/8	16-3/8 24 -	6-3/4 6-3/4 12-5/8	2-3/8 2-3/8 10	- 10 46	46 46 46	13-1/8 13-1/8 13-1/4	34@741# 10@861# 10@814#		
	94'	GLCSLX500-8 (S or AL)-94	500	Steel	30'	2-3/4	7-1/8	6.5'	13-1/2	21	28-3/8	6-3/4	2-3/8	14-3/8	54	13-1/8	8@1,007#		
	103'	GLC500-8 (S or AL)-103 GLCS500-8 (S or AL)-103 AL500-8-103 GLCSL500-8 (S or AL)-103	500 500 500 500	Steel Steel Alum. Steel	6' 20' 20' 25'	2-3/4 2-3/4 2-5/8 2-3/4	7-1/8 7-1/8 7-1/4 7-1/8	6.5' 6.5' 6.5' 6.5'	13-1/2 13-1/2 13-1/2 13-1/2	9 16-5/8 23-7/8 19	16-3/8 24 -	6-3/4 6-3/4 12-5/8 6-3/4	2-3/8 2-3/8 10 2-3/8	- 10 54 12-3/8	54 54 54 54	13-1/8 13-1/8 13-1/4 13-1/8	42@741# 12@861# 12@814# 10@959#		
	124'	GLCSLX500-8 (S or AL)-124	500	Steel	30'	2-3/4	7-1/8	6.5'	13-1/2	21	28-3/8	6-3/4	2-3/8	14-3/8	54	13-1/8	10@1,007#		
10'	11' 6"	GLC500-10 (S or AL)-11.5 GLCS500-10 (S or AL)-11.5 AL500-10-11.5	500 500 500	Steel Steel Alum.	6' 20' 20'	2-3/4 2-3/4 2-5/8	7-1/8 7-1/8 7-1/4	8' 8' 8'	10-1/2 10-1/2 16-7/8	8-7/8 16-5/8 23-7/8	16-3/8 24 -	7-1/4 7-1/4 12-5/8	2-3/8 2-3/8 10	- 10 9	9 9 9	13-1/8 13-1/8 13-1/4	6@756# 4@876# 4@819#		
	23'	GLC500-10 (S or AL)-23 GLCS500-10 (S or AL)-23 AL500-10-23	500 500 500	Steel Steel Alum.	6' 20' 20'	2-3/4 2-3/4 2-5/8	7-1/8 7-1/8 7-1/4	8' 8' 8'	10-1/2 10-1/2 16-7/8	8-7/8 16-5/8 23-7/8	16-3/8 24 -	7-1/4 7-1/4 12-5/8	2-3/8 2-3/8 10	- 10 13	9 9 13	13-1/8 13-1/8 13-1/4	10@756# 4@876# 4@819#		
	28'	GLCSL500-10 (S or AL)-28	500	Steel	25'	2-3/4	7-1/8	8'	10-1/2	19	26-3/8	7-1/4	2-3/8	12-3/8	9	13-1/8	4@1,022#		
	33'	GLC500-10 (S or AL)-33 GLCS500-10 (S or AL)-33 AL500-10-33	500 500 500	Steel Steel Alum.	6' 20' 20'	2-3/4 2-3/4 2-5/8	7-1/8 7-1/8 7-1/4	8' 8' 8'	10-1/2 10-1/2 16-7/8	8-7/8 16-5/8 23-7/8	16-3/8 24 -	7-1/4 7-1/4 12-5/8	2-3/8 2-3/8 10	- 10 19	9 9 19	13-1/8 13-1/8 13-1/4	14@756# 6@876# 6@819#		
	34'	GLCSLX500-10 (S or AL)-34	500	Steel	30'	2-3/4	7-1/8	8'	10-1/2	21	28-3/8	7-1/4	2-3/8	14-3/8	9	13-1/8	4@1,022#		
	43'	GLC500-10 (S or AL)-43 GLCS500-10 (S or AL)-43 AL500-10-43	500 500 500	Steel Steel Alum.	6' 20' 20'	2-3/4 2-3/4 2-5/8	7-1/8 7-1/8 7-1/4	8' 8' 8'	10-1/2 10-1/2 16-7/8	8-7/8 16-5/8 23-7/8	16-3/8 24 -	7-1/4 7-1/4 12-5/8	2-3/8 2-3/8 10	- 10 13	13 13 26	13-1/8 13-1/8 13-1/4	18@756# 6@876# 6@819#		
	53'	GLC500-10 (S or AL)-53 GLCS500-10 (S or AL)-53 AL500-10-53 GLCSL500-10 (S or AL)-53	500 500 500 500	Steel Steel Alum. Steel	6' 20' 20' 25'	2-3/4 2-3/4 2-5/8 2-3/4	7-1/8 7-1/8 7-1/4 7-1/8	8' 8' 8' 8'	10-1/2 10-1/2 16-7/8 10-1/2	8-7/8 16-5/8 23-7/8 19	16-3/8 24 -	7-1/4 7-1/4 12-5/8 7-1/4	2-3/8 2-3/8 10 2-3/8	- 10 13 12-3/8	13 13 30 13	13-1/8 13-1/8 13-1/4 13-1/8	22@756# 8@876# 8@819# 6@973#		
	63'	GLC500-10 (S or AL)-63 GLCS500-10 (S or AL)-63 AL500-10-63	500 500 500	Steel Steel Alum.	6' 20' 20'	2-3/4 2-3/4 2-5/8	7-1/8 7-1/8 7-1/4	8' 8' 8'	10-1/2 10-1/2 16-7/8	8-7/8 16-5/8 23-7/8	16-3/8 24 -	7-1/4 7-1/4 12-5/8	2-3/8 2-3/8 10	- 10 19	19 19 36	13-1/8 13-1/8 13-1/4	26@756# 8@876# 8@819#		
	64'	GLCSLX500-10 (S or AL)-64	500	Steel	30'	2-3/4	7-1/8	8'	16-7/8	21	28-3/8	7-1/4	2-3/8	14-3/8	36	13-1/8	6@1,022#		
	78'	GLCSL500-10 (S or AL)-78	500	Steel	25'	2-3/4	7-1/8	8'	16-7/8	19	26-3/8	7-1/4	2-3/8	12-3/8	46	13-1/8	8@973#		
	83'	GLC500-10 (S or AL)-83 GLCS500-10 (S or AL)-83 AL500-10-83	500 500 500	Steel Steel Alum.	6' 20' 20'	2-3/4 2-3/4 2-5/8	7-1/8 7-1/8 7-1/4	8' 8' 8'	16-7/8 16-7/8 16-7/8	8-7/8 16-5/8 23-7/8	16-3/8 24 -	7-1/4 7-1/4 12-5/8	2-3/8 2-3/8 10	- 10 46	46 46 46	13-1/8 13-1/8 13-1/4	34@756# 10@876# 10@819#		
	94'	GLCSLX500-10 (S or AL)-94	500	Steel	30'	2-3/4	7-1/8	8'	16-7/8	21	28-3/8	7-1/4	2-3/8	14-3/8	54	13-1/8	8@1,022#		
	103'	GLC500-10 (S or AL)-103 GLCS500-10 (S or AL)-103 AL500-10-103 GLCSL500-10 (S or AL)-103	500 500 500 500	Steel Steel Alum. Steel	6' 20' 20' 25'	2-3/4 2-3/4 2-5/8 2-3/4	7-1/8 7-1/8 7-1/4 7-1/8	8' 8' 8' 8'	16-7/8 16-7/8 16-7/8 16-7/8	8-7/8 16-5/8 23-7/8 19	16-3/8 24 -	7-1/4 7-1/4 12-5/8 7-1/4	2-3/8 2-3/8 10 2-3/8	- 10 54 12-3/8	54 54 54 54	13-1/8 13-1/8 13-1/4 13-1/8	42@756# 12@876# 12@819# 10@973#		
	124'	GLCSLX500-10 (S or AL)-124	500	Steel	30'	2-3/4	7-1/8	8'	16-7/8	21	28-3/8	7-1/4	2-3/8	14-3/8	54	13-1/8	10@1,022#		

*This column provides the total number of support hangers with the corresponding vertical load applied by each support hanger (in pounds) based on the "L1" dimensions shown. Up to a 20" hanger drop will be provided by Gorbel. Additional hanger points or longer drops can be provided at an additional charge.

Gorbel® Work Station Bridge Crane kits include: bridge, runways, hoist trolley, end trucks, end stops, flat wire festooning, festoon gliders (festoon trolleys on steel runway lengths greater than 63' and all aluminum systems), festoon stack-up section, splice joints and hanger brackets. Sway bracing is required on all systems except flush mounted systems (by others). Sway bracing kits are available but are not included in the crane kit.

Dimensions are for reference only and are subject to change without notice.

CEILING MOUNTED WORK STATION BRIDGE CRANES - 500# CAPACITY

BRIDGE LENGTH (L)	RUNWAY LENGTH	MODEL NUMBER	TRACK SERIES	TRACK MATL.	MAX. L1	BRIDGE										RUNWAY		
						T1	L3	L4	L6	H3	H3A	H4	H2	H1	L7	L8	HANGERS (See Note)*	
						in	in	ft	in	in	in	in	in	in	in	in		
15'	23'	GLC500-15 (S or AL)-23 GLCS500-15 (S or AL)-23 AL500-15-23	500 500 500	Steel Steel Alum.	6' 20' 20'	2-3/4 2-3/4 2-5/8	7-1/8 7-1/8 7-1/4	13' 13' 13'	21-3/4 21-3/4 23-5/8	8-7/8 16-5/8 23-7/8	16-3/8 24 -	12-7/8 12-7/8 12-5/8	2-3/8 2-3/8 10	- 10 -	9 9 13	13-1/8 13-1/8 13-1/4	10@774# 4@894# 4@831#	
	28'	GLCSL500-15 (S or AL)-28	500	Steel	25'	2-3/4	7-1/8	13'	21-3/4	19	26-3/8	12-7/8	2-3/8	12-3/8	9	13-1/8	4@992#	
	33'	GLC500-15 (S or AL)-33 GLCS500-15 (S or AL)-33 AL500-15-33	500 500 500	Steel Steel Alum.	6' 20' 20'	2-3/4 2-3/4 2-5/8	7-1/8 7-1/8 7-1/4	13' 13' 13'	21-3/4 21-3/4 23-5/8	8-7/8 16-5/8 23-7/8	16-3/8 24 -	12-7/8 12-7/8 12-5/8	2-3/8 2-3/8 10	- 10 -	9 9 19	13-1/8 13-1/8 13-1/4	14@774# 6@894# 6@831#	
	34'	GLCSLX500-15 (S or AL)-34	500	Steel	30'	2-3/4	7-1/8	13'	21-3/4	21	28-3/8	12-7/8	2-3/8	14-3/8	9	13-1/8	4@1,040#	
	43'	GLC500-15 (S or AL)-43 GLCS500-15 (S or AL)-43 AL500-15-43	500 500 500	Steel Steel Alum.	6' 20' 20'	2-3/4 2-3/4 2-5/8	7-1/8 7-1/8 7-1/4	13' 13' 13'	21-3/4 21-3/4 23-5/8	8-7/8 16-5/8 23-7/8	16-3/8 24 -	12-7/8 12-7/8 12-5/8	2-3/8 2-3/8 10	- 10 -	13 13 26	13-1/8 13-1/8 13-1/4	18@774# 6@894# 6@831#	
	53'	GLC500-15 (S or AL)-53 GLCS500-15 (S or AL)-53 AL500-15-53	500 500 500	Steel Steel Alum.	6' 20' 20'	2-3/4 2-3/4 2-5/8	7-1/8 7-1/8 7-1/4	13' 13' 13'	21-3/4 21-3/4 23-5/8	8-7/8 16-5/8 23-7/8	16-3/8 24 -	12-7/8 12-7/8 12-5/8	2-3/8 2-3/8 10	- 10 -	13 13 30	13-1/8 13-1/8 13-1/4	22@774# 8@894# 8@831#	
	63'	GLC500-15 (S or AL)-63 GLCS500-15 (S or AL)-63 AL500-15-63	500 500 500	Steel Steel Alum.	6' 20' 20'	2-3/4 2-3/4 2-5/8	7-1/8 7-1/8 7-1/4	13' 13' 13'	21-3/4 21-3/4 23-5/8	8-7/8 16-5/8 23-7/8	16-3/8 24 -	12-7/8 12-7/8 12-5/8	2-3/8 2-3/8 10	- 10 -	19 19 36	13-1/8 13-1/8 13-1/4	26@774# 8@894# 8@831#	
	64'	GLCSLX500-15 (S or AL)-64	500	Steel	30'	2-3/4	7-1/8	13'	23-5/8	21	28-3/8	12-7/8	2-3/8	14-3/8	36	13-1/8	6@1,040#	
	78'	GLCSL500-15 (S or AL)-78	500	Steel	25'	2-3/4	7-1/8	13'	23-5/8	19	26-3/8	12-7/8	2-3/8	12-3/8	46	13-1/8	8@992#	
	83'	GLC500-15 (S or AL)-83 GLCS500-15 (S or AL)-83 AL500-15-83	500 500 500	Steel Steel Alum.	6' 20' 20'	2-3/4 2-3/4 2-5/8	7-1/8 7-1/8 7-1/4	13' 13' 13'	23-5/8 23-5/8 23-5/8	8-7/8 16-5/8 23-7/8	16-3/8 24 -	12-7/8 12-7/8 12-5/8	2-3/8 2-3/8 10	- 10 -	46 46 46	13-1/8 13-1/8 13-1/4	34@774# 10@894# 10@831#	
	94'	GLCSLX500-15 (S or AL)-94	500	Steel	30'	2-3/4	7-1/8	13'	23-5/8	21	28-3/8	12-7/8	2-3/8	14-3/8	54	13-1/8	8@1,040#	
	103'	GLC500-15 (S or AL)-103 GLCS500-15 (S or AL)-103 AL500-15-103	500 500 500	Steel Steel Alum.	6' 20' 20'	2-3/4 2-3/4 2-5/8	7-1/8 7-1/8 7-1/4	13' 13' 13'	23-5/8 23-5/8 23-5/8	8-7/8 16-5/8 23-7/8	16-3/8 24 -	12-7/8 12-7/8 12-5/8	2-3/8 2-3/8 10	- 10 -	54 54 54	13-1/8 13-1/8 13-1/4	42@774# 12@894# 12@831#	
124'	GLCSLX500-15 (S or AL)-124	500	Steel	30'	2-3/4	7-1/8	13'	23-5/8	21	28-3/8	12-7/8	2-3/8	14-3/8	54	13-1/8	10@1,040#		
20'	23'	GLC500-20 (S or AL)-23 GLCS500-20 (S or AL)-23 AL500-20-23	500 500 500	Steel Steel Alum.	6' 20' 20'	2-3/4 2-3/4 2-5/8	7-1/8 7-1/8 7-1/4	18' 18' 18'	21-3/4 21-3/4 27	8-7/8 16-5/8 23-7/8	16-3/8 24 -	12-7/8 12-7/8 12-5/8	2-3/8 2-3/8 10	- 10 -	9 9 13	13-1/8 13-1/8 13-1/4	10@792# 4@912# 4@842#	
	28'	GLCSL500-20 (S or AL)-28	500	Steel	25'	2-3/4	7-1/8	18'	21-3/4	19	26-3/8	12-7/8	2-3/8	12-3/8	9	13-1/8	4@1,009#	
	33'	GLC500-20 (S or AL)-33 GLCS500-20 (S or AL)-33 AL500-20-33	500 500 500	Steel Steel Alum.	6' 20' 20'	2-3/4 2-3/4 2-5/8	7-1/8 7-1/8 7-1/4	18' 18' 18'	21-3/4 21-3/4 27	8-7/8 16-5/8 23-7/8	16-3/8 24 -	12-7/8 12-7/8 12-5/8	2-3/8 2-3/8 10	- 10 -	9 9 19	13-1/8 13-1/8 13-1/4	14@792# 6@912# 6@842#	
	34'	GLCSLX500-20 (S or AL)-34	500	Steel	30'	2-3/4	7-1/8	18'	21-3/4	21	28-3/8	12-7/8	2-3/8	14-3/8	9	13-1/8	4@1,058#	
	43'	GLC500-20 (S or AL)-43 GLCS500-20 (S or AL)-43 AL500-20-43	500 500 500	Steel Steel Alum.	6' 20' 20'	2-3/4 2-3/4 2-5/8	7-1/8 7-1/8 7-1/4	18' 18' 18'	21-3/4 21-3/4 27	8-7/8 16-5/8 23-7/8	16-3/8 24 -	12-7/8 12-7/8 12-5/8	2-3/8 2-3/8 10	- 10 -	13 13 26	13-1/8 13-1/8 13-1/4	18@792# 8@912# 6@842#	
	53'	GLC500-20 (S or AL)-53 GLCS500-20 (S or AL)-53 AL500-20-53	500 500 500	Steel Steel Alum.	6' 20' 20'	2-3/4 2-3/4 2-5/8	7-1/8 7-1/8 7-1/4	18' 18' 18'	21-3/4 21-3/4 27	8-7/8 16-5/8 23-7/8	16-3/8 24 -	12-7/8 12-7/8 12-5/8	2-3/8 2-3/8 10	- 10 -	13 13 30	13-1/8 13-1/8 13-1/4	22@792# 8@912# 8@842#	
	63'	GLC500-20 (S or AL)-63 GLCS500-20 (S or AL)-63 AL500-20-63	500 500 500	Steel Steel Alum.	6' 20' 20'	2-3/4 2-3/4 2-5/8	7-1/8 7-1/8 7-1/4	18' 18' 18'	21-3/4 21-3/4 27	8-7/8 16-5/8 23-7/8	16-3/8 24 -	12-7/8 12-7/8 12-5/8	2-3/8 2-3/8 10	- 10 -	19 19 36	13-1/8 13-1/8 13-1/4	26@792# 8@912# 8@842#	
	64'	GLCSLX500-20 (S or AL)-64	500	Steel	30'	2-3/4	7-1/8	18'	27	21	28-3/8	12-7/8	2-3/8	14-3/8	36	13-1/8	6@1,058#	
	78'	GLCSL500-20 (S or AL)-78	500	Steel	25'	2-3/4	7-1/8	18'	27	19	26-3/8	12-7/8	2-3/8	12-3/8	46	13-1/8	8@1,009#	
	83'	GLC500-20 (S or AL)-83 GLCS500-20 (S or AL)-83 AL500-20-83	500 500 500	Steel Steel Alum.	6' 20' 20'	2-3/4 2-3/4 2-5/8	7-1/8 7-1/8 7-1/4	18' 18' 18'	27 27 27	8-7/8 16-5/8 23-7/8	16-3/8 24 -	12-7/8 12-7/8 12-5/8	2-3/8 2-3/8 10	- 10 -	46 46 46	13-1/8 13-1/8 13-1/4	34@792# 10@912# 10@842#	
	94'	GLCSLX500-20 (S or AL)-94	500	Steel	30'	2-3/4	7-1/8	18'	27	21	28-3/8	12-7/8	2-3/8	14-3/8	54	13-1/8	8@1,058#	
	103'	GLC500-20 (S or AL)-103 GLCS500-20 (S or AL)-103 AL500-20-103	500 500 500	Steel Steel Alum.	6' 20' 20'	2-3/4 2-3/4 2-5/8	7-1/8 7-1/8 7-1/4	18' 18' 18'	27 27 27	8-7/8 16-5/8 23-7/8	16-3/8 24 -	12-7/8 12-7/8 12-5/8	2-3/8 2-3/8 10	- 10 -	54 54 54	13-1/8 13-1/8 13-1/4	42@792# 12@912# 12@842#	
124'	GLCSLX500-20 (S or AL)-124	500	Steel	30'	2-3/4	7-1/8	18'	27	21	28-3/8	12-7/8	2-3/8	14-3/8	54	13-1/8	10@1,058#		

*This column provides the total number of support hangers with the corresponding vertical load applied by each support hanger (in pounds) based on the "L1" dimensions shown. Up to a 20" hanger drop will be provided by Gorbel. Additional hanger points or longer drops can be provided at an additional charge.

Gorbel® Work Station Bridge Crane kits include: bridge, runways, hoist trolley, end trucks, end stops, flat wire festooning, festoon gliders (festoon trolleys on steel runway lengths greater than 63' and all aluminum systems), festoon stack-up section, splice joints and hanger brackets. Sway bracing is required on all systems except flush mounted systems (by others). Sway bracing kits are available but are not included in the crane kit.

Dimensions are for reference only and are subject to change without notice.

CEILING MOUNTED WORK STATION BRIDGE CRANES - 500# CAPACITY

BRIDGE LENGTH (L)	RUNWAY LENGTH	MODEL NUMBER	TRACK SERIES	TRACK MATL.	MAX. L1	BRIDGE								RUNWAY			
						T1 in	L3 in	L4 ft	L6 in	H3 in	H3A in	H4 in	H2 in	H1 in	L7 in	L8 in	HANGERS (See Note)*
23'	23'	GLC500-23 (S or AL)-23 GLCS500-23 (S or AL)-23 AL500-23-23	500 500 500	Steel Steel Alum.	6' 20' 20'	2-3/4 2-3/4 2-5/8	7-1/8 7-1/8 7-1/4	21' 21' 20'	21-3/4 21-3/4 30-3/8	8-7/8 16-5/8 23-7/8	16-3/8 24 -	12-7/8 12-7/8 12-5/8	2-3/8 2-3/8 10	- - 13	9 9 13	13-1/8 13-1/8 13-1/4	10@803# 4@923# 4@850#
	28'	GLCSL500-23 (S or AL)-28	500	Steel	25'	2-3/4	7-1/8	21'	21-3/4	19	26-3/8	12-7/8	2-3/8	12-3/8	9	13-1/8	4@1,020#
	33'	GLC500-23 (S or AL)-33 GLCS500-23 (S or AL)-33 AL500-23-33	500 500 500	Steel Steel Alum.	6' 20' 20'	2-3/4 2-3/4 2-5/8	7-1/8 7-1/8 7-1/4	21' 21' 20'	21-3/4 21-3/4 30-3/8	8-7/8 16-5/8 23-7/8	16-3/8 24 -	12-7/8 12-7/8 12-5/8	2-3/8 2-3/8 10	10 - 19	9 9 13	13-1/8 13-1/8 13-1/4	14@803# 6@923# 6@850#
	34'	GLCSLX500-23 (S or AL)-34	500	Steel	30'	2-3/4	7-1/8	21'	21-3/4	21	28-3/8	12-7/8	2-3/8	14-3/8	9	13-1/8	4@1,069#
	43'	GLC500-23 (S or AL)-43 GLCS500-23 (S or AL)-43 AL500-23-43	500 500 500	Steel Steel Alum.	6' 20' 20'	2-3/4 2-3/4 2-5/8	7-1/8 7-1/8 7-1/4	21' 21' 20'	21-3/4 21-3/4 30-3/8	8-7/8 16-5/8 23-7/8	16-3/8 24 -	12-7/8 12-7/8 12-5/8	2-3/8 2-3/8 10	- 10 26	13 13 26	13-1/8 13-1/8 13-1/4	18@803# 6@923# 6@850#
	53'	GLC500-23 (S or AL)-53 GLCS500-23 (S or AL)-53 AL500-23-53 GLCSL500-23 (S or AL)-53	500 500 500 500	Steel Steel Alum. Steel	6' 20' 20' 25'	2-3/4 2-3/4 2-5/8 2-3/4	7-1/8 7-1/8 7-1/4 7-1/8	21' 21' 20' 21'	21-3/4 21-3/4 30-3/8 21-3/4	8-7/8 16-5/8 23-7/8 19	16-3/8 24 -	12-7/8 12-7/8 12-5/8 12-7/8	2-3/8 2-3/8 10 2-3/8	- 10 30 13	13 13 30 13	13-1/8 13-1/8 13-1/4 13-1/8	22@803# 8@923# 8@850# 6@1,020#
	63'	GLC500-23 (S or AL)-63 GLCS500-23 (S or AL)-63 AL500-23-63	500 500 500	Steel Steel Alum.	6' 20' 20'	2-3/4 2-3/4 2-5/8	7-1/8 7-1/8 7-1/4	21' 21' 20'	21-3/4 21-3/4 30-3/8	8-7/8 16-5/8 23-7/8	16-3/8 24 -	12-7/8 12-7/8 12-5/8	2-3/8 2-3/8 10	10 19 36	19 13 36	13-1/8 13-1/8 13-1/4	26@803# 8@923# 8@850#
	64'	GLCSLX500-23 (S or AL)-64	500	Steel	30'	2-3/4	7-1/8	21'	30-3/8	21	28-3/8	12-7/8	2-3/8	14-3/8	36	13-1/8	6@1,069#
	78'	GLCSL500-23 (S or AL)-78	500	Steel	25'	2-3/4	7-1/8	21'	30-3/8	19	26-3/8	12-7/8	2-3/8	12-3/8	46	13-1/8	8@1,020#
	83'	GLC500-23 (S or AL)-83 GLCS500-23 (S or AL)-83 AL500-23-83	500 500 500	Steel Steel Alum.	6' 20' 20'	2-3/4 2-3/4 2-5/8	7-1/8 7-1/8 7-1/4	21' 21' 20'	30-3/8 30-3/8 30-3/8	8-7/8 16-5/8 23-7/8	16-3/8 24 -	12-7/8 12-7/8 12-5/8	2-3/8 2-3/8 10	- 10 46	46 46 46	13-1/8 13-1/8 13-1/4	34@803# 10@923# 10@850#
	94'	GLCSLX500-23 (S or AL)-94	500	Steel	30'	2-3/4	7-1/8	21'	30-3/8	21	28-3/8	12-7/8	2-3/8	14-3/8	54	13-1/8	8@1,069#
	103'	GLC500-23 (S or AL)-103 GLCS500-23 (S or AL)-103 AL500-23-103 GLCSL500-23 (S or AL)-103	500 500 500 500	Steel Steel Alum. Steel	6' 20' 20' 25'	2-3/4 2-3/4 2-5/8 2-3/4	7-1/8 7-1/8 7-1/4 7-1/8	21' 21' 20' 21'	30-3/8 30-3/8 30-3/8 30-3/8	8-7/8 16-5/8 23-7/8 19	16-3/8 24 -	12-7/8 12-7/8 12-5/8 12-7/8	2-3/8 2-3/8 10 2-3/8	10 54 54 12	54 13-1/8 13-1/4 13-1/8	42@803# 12@923# 12@850# 10@1,020#	
	124'	GLCSLX500-23 (S or AL)-124	500	Steel	30'	2-3/4	7-1/8	21'	30-3/8	21	28-3/8	12-7/8	2-3/8	14-3/8	54	13-1/8	10@1,069#
	28'	23'	GLC500-28 (S or AL)-23 GLCS500-28 (S or AL)-23 AL500-28-23	500 500 500	Steel Steel Alum.	6' 20' 20'	2-3/4 2-3/4 2-5/8	7-1/8 7-1/8 7-1/4	25' 25' 25'	31-1/4 31-1/4 37-1/8	10-5/8 18-1/4 22-3/4	15-1/8 22-3/4 -	15-1/4 15-1/4 13-1/4	2-3/8 2-3/8 10-1/2	- 10 13	9 9 22	22-1/8 22-1/8 23-3/8
28'		GLCSL500-28 (S or AL)-28	500	Steel	25'	2-3/4	7-1/8	25'	31-1/4	20-5/8	25-1/8	15-1/4	2-3/8	12-3/8	9	22-1/8	4@1,064#
33'		GLC500-28 (S or AL)-33 GLCS500-28 (S or AL)-33 AL500-28-33	500 500 500	Steel Steel Alum.	6' 20' 20'	2-3/4 2-3/4 2-5/8	7-1/8 7-1/8 7-1/4	25' 25' 25'	31-1/4 31-1/4 37-1/8	10-5/8 18-1/4 22-3/4	15-1/8 22-3/4 -	15-1/4 15-1/4 13-1/4	2-3/8 2-3/8 10-1/2	- 10 19	9 9 22	22-1/8 22-1/8 23-3/8	14@846# 6@966# 6@850#
34'		GLCSLX500-28 (S or AL)-34	500	Steel	30'	2-3/4	7-1/8	25'	31-1/4	22-5/8	27-1/8	15-1/4	2-3/8	14-3/8	9	22-1/8	4@1,113#
43'		GLC500-28 (S or AL)-43 GLCS500-28 (S or AL)-43 AL500-28-43	500 500 500	Steel Steel Alum.	6' 20' 20'	2-3/4 2-3/4 2-5/8	7-1/8 7-1/8 7-1/4	25' 25' 25'	31-1/4 31-1/4 37-1/8	10-5/8 18-1/4 22-3/4	15-1/8 22-3/4 -	15-1/4 15-1/4 13-1/4	2-3/8 2-3/8 10-1/2	- 10 26	13 13 26	22-1/8 22-1/8 23-3/8	18@846# 6@966# 6@850#
53'		GLC500-28 (S or AL)-53 GLCS500-28 (S or AL)-53 AL500-28-53 GLCSL500-28 (S or AL)-53	500 500 500 500	Steel Steel Alum. Steel	6' 20' 20' 25'	2-3/4 2-3/4 2-5/8 2-3/4	7-1/8 7-1/8 7-1/4 7-1/8	25' 25' 25' 25'	31-1/4 31-1/4 37-1/8 31-1/4	10-5/8 18-1/4 22-3/4 20-5/8	15-1/8 22-3/4 -	15-1/4 15-1/4 13-1/4 15-1/4	2-3/8 2-3/8 10-1/2 2-3/8	- 10 30 12	13 13 30 13	22-1/8 22-1/8 23-3/8 22-1/8	22@846# 8@966# 8@850# 6@1,064#
63'		GLC500-28 (S or AL)-63 GLCS500-28 (S or AL)-63 AL500-28-63	500 500 500	Steel Steel Alum.	6' 20' 20'	2-3/4 2-3/4 2-5/8	7-1/8 7-1/8 7-1/4	25' 25' 25'	31-1/4 31-1/4 37-1/8	10-5/8 18-1/4 22-3/4	15-1/8 22-3/4 -	15-1/4 15-1/4 13-1/4	2-3/8 2-3/8 10-1/2	- 10 36	19 19 36	22-1/8 22-1/8 23-3/8	26@846# 8@966# 8@850#
64'		GLCSLX500-28 (S or AL)-64	500	Steel	30'	2-3/4	7-1/8	25'	37-1/8	22-5/8	27-1/8	15-1/4	2-3/8	14-3/8	36	22-1/8	6@1,113#
78'		GLCSL500-28 (S or AL)-78	500	Steel	25'	2-3/4	7-1/8	25'	37-1/8	20-5/8	25-1/8	15-1/4	2-3/8	12-3/8	46	22-1/8	8@1,064#
83'		GLC500-28 (S or AL)-83 GLCS500-28 (S or AL)-83 AL500-28-83	500 500 500	Steel Steel Alum.	6' 20' 20'	2-3/4 2-3/4 2-5/8	7-1/8 7-1/8 7-1/4	25' 25' 25'	37-1/8 37-1/8 37-1/8	10-5/8 18-1/4 22-3/4	15-1/8 22-3/4 -	15-1/4 15-1/4 13-1/4	2-3/8 2-3/8 10-1/2	- 10 46	46 46 46	22-1/8 22-1/8 23-3/8	34@846# 10@966# 10@850#
94'		GLCSLX500-28 (S or AL)-94	500	Steel	30'	2-3/4	7-1/8	25'	37-1/8	22-5/8	27-1/8	15-1/4	2-3/8	14-3/8	54	22-1/8	8@1,113#
103'		GLC500-28 (S or AL)-103 GLCS500-28 (S or AL)-103 AL500-28-103 GLCSL500-28 (S or AL)-103	500 500 500 500	Steel Steel Alum. Steel	6' 20' 20' 25'	2-3/4 2-3/4 2-5/8 2-3/4	7-1/8 7-1/8 7-1/4 7-1/8	25' 25' 25' 25'	37-1/8 37-1/8 37-1/8 37-1/8	10-5/8 18-1/4 22-3/4 20-5/8	15-1/8 22-3/4 -	15-1/4 15-1/4 13-1/4 15-1/4	2-3/8 2-3/8 10-1/2 2-3/8	10 54 54 12	54 22-1/8 23-3/8 22-1/8	42@846# 12@966# 12@850# 10@1,064#	
124'		GLCSLX500-28 (S or AL)-124	500	Steel	30'	2-3/4	7-1/8	25'	37-1/8	22-5/8	27-1/8	15-1/4	2-3/8	14-3/8	54	22-1/8	10@1,113#

*This column provides the total number of support hangers with the corresponding vertical load applied by each support hanger (in pounds) based on the "L1" dimensions shown. Up to a 20" hanger drop will be provided by Gorbel. Additional hanger points or longer drops can be provided at an additional charge.

Gorbel® Work Station Bridge Crane kits include: bridge, runways, hoist trolley, end trucks, end stops, flat wire festooning, festoon gliders (festoon trolleys on steel runway lengths greater than 63' and all aluminum systems), festoon stack-up section, splice joints and hanger brackets. Sway bracing is required on all systems except flush mounted systems (by others). Sway bracing kits are available but are not included in the crane kit.

Dimensions are for reference only and are subject to change without notice.

CEILING MOUNTED WORK STATION BRIDGE CRANES - 500# CAPACITY

BRIDGE LENGTH (L)	RUNWAY LENGTH	MODEL NUMBER	TRACK SERIES	TRACK MATL.	MAX. L1	BRIDGE								RUNWAY				
						T1	L3	L4	L6	H3	H3A	H4	H2	H1	L7	L8	HANGERS (See Note)*	
						in	in	ft	in	in	in	in	in	in	in	in		
34'	28'	GLCSL500-34 (S or AL)-28	500	Steel	25'	2-3/4	7-1/8	30'	20-1/2	20-5/8	25-1/8	17-1/4	2-3/8	12-3/8	9	22-1/8	4@1,091#	
	33'	GLC500-34 (S or AL)-33	500	Steel	6'	2-3/4	7-1/8	30'	20-1/2	10-5/8	16-3/8	17-1/4	2-3/8	-	9	22-1/8	14@873#	
		GLCS500-34 (S or AL)-33 AL500-34-33	500 500	Steel Alum.	20' 20'	2-3/4 2-5/8	7-1/8 7-1/4	30' 30'	20-1/2 43-7/8	18-1/4 22-3/4	22-3/4 -	17-1/4 15-3/8	2-3/8 12-5/8	10 13	9 23-3/8	22-1/8 23-3/8	6@993# 6@850#	
	34'	GLCSLX500-34 (S or AL)-34	500	Steel	30'	2-3/4	7-1/8	30'	20-1/2	22-5/8	27-1/8	17-1/4	2-3/8	14-3/8	9	22-1/8	4@1,139#	
	43'	GLC500-34 (S or AL)-43	500	Steel	6'	2-3/4	7-1/8	30'	20-1/2	10-5/8	16-3/8	17-1/4	2-3/8	-	13	22-1/8	18@873#	
		GLCS500-34 (S or AL)-43 AL500-34-43	500 500	Steel Alum.	20' 20'	2-3/4 2-5/8	7-1/8 7-1/4	30' 30'	20-1/2 43-7/8	18-1/4 22-3/4	22-3/4 -	17-1/4 15-3/8	2-3/8 12-5/8	10 26	13 23-3/8	22-1/8 23-3/8	6@993# 6@850#	
	53'	GLC500-34 (S or AL)-53	500	Steel	6'	2-3/4	7-1/8	30'	20-1/2	10-5/8	16-3/8	17-1/4	2-3/8	-	13	22-1/8	22@873#	
		GLCS500-34 (S or AL)-53 AL500-34-53	500 500	Steel Alum.	20' 20'	2-3/4 2-5/8	7-1/8 7-1/4	30' 30'	20-1/2 43-7/8	18-1/4 22-3/4	22-3/4 -	17-1/4 15-3/8	2-3/8 12-5/8	10 30	13 23-3/8	22-1/8 23-3/8	8@993# 8@850#	
	63'	GLCSL500-34 (S or AL)-53	500	Steel	25'	2-3/4	7-1/8	30'	20-1/2	20-5/8	25-1/8	17-1/4	2-3/8	12-3/8	13	22-1/8	6@1,091#	
		GLC500-34 (S or AL)-63 GLCS500-34 (S or AL)-63 AL500-34-63	500 500 500	Steel Steel Alum.	6' 20' 20'	2-3/4 2-3/4 2-5/8	7-1/8 7-1/8 7-1/4	30' 30' 30'	20-1/2 20-1/2 43-7/8	10-5/8 18-1/4 22-3/4	16-3/8 22-3/4 -	17-1/4 17-1/4 15-3/8	2-3/8 2-3/8 12-5/8	- 10 -	19 19 36	22-1/8 22-1/8 23-3/8	26@873# 8@993# 8@850#	
	64'	GLCSLX500-34 (S or AL)-64	500	Steel	30'	2-3/4	7-1/8	30'	43-7/8	22-5/8	27-1/8	17-1/4	2-3/8	14-3/8	36	22-1/8	6@1,139#	
	78'	GLCSL500-34 (S or AL)-78	500	Steel	25'	2-3/4	7-1/8	30'	43-7/8	20-5/8	25-1/8	17-1/4	2-3/8	12-3/8	46	22-1/8	8@1,091#	
	83'	GLC500-34 (S or AL)-83	500	Steel	6'	2-3/4	7-1/8	30'	43-7/8	10-5/8	16-3/8	17-1/4	2-3/8	-	46	22-1/8	34@873#	
		GLCS500-34 (S or AL)-83 AL500-34-83	500 500	Steel Alum.	20' 20'	2-3/4 2-5/8	7-1/8 7-1/4	30' 30'	43-7/8 43-7/8	18-1/4 22-3/4	22-3/4 -	17-1/4 15-3/8	2-3/8 12-5/8	10 46	46 23-3/8	22-1/8 23-3/8	10@993# 10@850#	
94'	GLCSLX500-34 (S or AL)-94	500	Steel	30'	2-3/4	7-1/8	30'	43-7/8	22-5/8	27-1/8	17-1/4	2-3/8	14-3/8	54	22-1/8	8@1,139#		
103'	GLC500-34 (S or AL)-103	500	Steel	6'	2-3/4	7-1/8	30'	43-7/8	10-5/8	16-3/8	17-1/4	2-3/8	-	54	22-1/8	42@873#		
	GLCS500-34 (S or AL)-103 AL500-34-103	500 500	Steel Alum.	20' 20'	2-3/4 2-5/8	7-1/8 7-1/4	30' 30'	43-7/8 43-7/8	18-1/4 22-3/4	22-3/4 -	17-1/4 15-3/8	2-3/8 12-5/8	10 54	54 23-3/8	22-1/8 23-3/8	12@993# 12@850#		
124'	GLCSLX500-34 (S or AL)-124	500	Steel	30'	2-3/4	7-1/8	30'	43-7/8	22-5/8	27-1/8	17-1/4	2-3/8	14-3/8	54	22-1/8	10@1,139#		

*This column provides the total number of support hangers with the corresponding vertical load applied by each support hanger (in pounds) based on the "L1" dimensions shown. Up to a 20" hanger drop will be provided by Gorbel. Additional hanger points or longer drops can be provided at an additional charge.

Gorbel® Work Station Bridge Crane kits include: bridge, runways, hoist trolley, end trucks, end stops, flat wire festooning, festoon gliders (festoon trolleys on steel runway lengths greater than 63' and all aluminum systems), festoon stack-up section, splice joints and hanger brackets. Sway bracing is required on all systems except flush mounted systems (by others). Sway bracing kits are available but are not included in the crane kit.

Dimensions are for reference only and are subject to change without notice.

CEILING MOUNTED WORK STATION BRIDGE CRANES - 1000# CAPACITY

BRIDGE LENGTH (L)	RUNWAY LENGTH	MODEL NUMBER	TRACK SERIES	TRACK MATL.	MAX. L1	BRIDGE								RUNWAY				
						T1	L3	L4	L6	H3	H3A	H4	H2	H1	L7	L8	HANGERS (See Note)*	
						in	in	ft	in	in	in	in	in	in	in	in		
8'	11' 6"	GLC1000-8 (S or AL)-11.5 GLCS1000-8 (S or AL)-11.5 AL1000-8-11.5	1000 1000 1000	Steel Steel Alum.	6' 20' 20'	3 3 2-5/8	7-7/8 7-7/8 7-7/8	6.5' 6.5' 6.5'	11-3/8 11-3/8 14-1/8	10-1/8 18 21-7/8	14-1/8 22-1/8 -	7-5/8 7-5/8 7-3/4	3 3 5-1/8	- 11 -	9 9 9	15 15 15	6@1,465# 4@1,668# 4@1,600#	
	23'	GLC1000-8 (S or AL)-23 GLCS1000-8 (S or AL)-23 AL1000-8-23	1000 1000 1000	Steel Steel Alum.	6' 20' 20'	3 3 2-5/8	7-7/8 7-7/8 7-7/8	6.5' 6.5' 6.5'	11-3/8 11-3/8 14-1/8	10-1/8 18 21-7/8	14-1/8 22-1/8 -	7-5/8 7-5/8 7-3/4	3 3 5-1/8	- 11 -	9 9 13	15 15 15	10@1,465# 4@1,668# 4@1,600#	
	28'	GLCSL1000-8 (S or AL)-28	1000	Steel	25'	3	7-7/8	6.5'	11-3/8	20-7/8	25	7-5/8	3	13-7/8	13	15	4@1,760#	
	33'	GLC1000-8 (S or AL)-33 GLCS1000-8 (S or AL)-33 AL1000-8-33	1000 1000 1000	Steel Steel Alum.	6' 20' 20'	3 3 2-5/8	7-7/8 7-7/8 7-7/8	6.5' 6.5' 6.5'	11-3/8 11-3/8 14-1/8	10-1/8 18 21-7/8	14-1/8 22-1/8 -	7-5/8 7-5/8 7-3/4	3 3 5-1/8	- 11 -	13 13 19	15 15 15	14@1,465# 4@1,668# 6@1,600#	
	34'	GLCSLX1000-8 (S or AL)-34	1000	Steel	30'	3	7-7/8	6.5'	11-3/8	24	28-1/8	7-5/8	3	17	13	15	4@1,885#	
	43'	GLC1000-8 (S or AL)-43 GLCS1000-8 (S or AL)-43 AL1000-8-43	1000 1000 1000	Steel Steel Alum.	6' 20' 20'	3 3 2-5/8	7-7/8 7-7/8 7-7/8	6.5' 6.5' 6.5'	11-3/8 11-3/8 14-1/8	10-1/8 18 21-7/8	14-1/8 22-1/8 -	7-5/8 7-5/8 7-3/4	3 3 5-1/8	11 -	19 19 26	15 15 15	18@1,465# 6@1,668# 6@1,600#	
	53'	GLC1000-8 (S or AL)-53 GLCS1000-8 (S or AL)-53 AL1000-8-53 GLCSL1000-8 (S or AL)-53	1000 1000 1000 1000	Steel Steel Alum. Steel	6' 20' 20' 25'	3 3 2-5/8 3	7-7/8 7-7/8 7-7/8 7-7/8	6.5' 6.5' 6.5' 6.5'	11-3/8 11-3/8 14-1/8 11-3/8	10-1/8 18 21-7/8 20-7/8	14-1/8 22-1/8 -	7-5/8 7-5/8 7-3/4 7-5/8	3 3 5-1/8 3	- 11 -	19 19 30 19	15 15 15 15	22@1,465# 8@1,668# 8@1,600# 6@1,760#	
	63'	GLC1000-8 (S or AL)-63 GLCS1000-8 (S or AL)-63 AL1000-8-63	1000 1000 1000	Steel Steel Alum.	6' 20' 20'	3 3 2-5/8	7-7/8 7-7/8 7-7/8	6.5' 6.5' 6.5'	11-3/8 11-3/8 14-1/8	10-1/8 18 21-7/8	14-1/8 22-1/8 -	7-5/8 7-5/8 7-3/4	3 3 5-1/8	- 11 -	26 26 36	15 15 15	26@1,465# 8@1,668# 8@1,600#	
	64'	GLCSLX1000-8 (S or AL)-64	1000	Steel	30'	3	7-7/8	6.5'	23-3/8	24	28-1/8	7-5/8	3	17	36	15	6@1,885#	
	78'	GLCSL1000-8 (S or AL)-78	1000	Steel	25'	3	7-7/8	6.5'	23-3/8	20-7/8	25	7-5/8	3	13-7/8	46	15	8@1,760#	
	83'	GLC1000-8 (S or AL)-83 GLCS1000-8 (S or AL)-83 AL1000-8-83	1000 1000 1000	Steel Steel Alum.	6' 20' 20'	3 3 2-5/8	7-7/8 7-7/8 7-7/8	6.5' 6.5' 6.5'	23-3/8 23-3/8 14-1/8	10-1/8 18 21-7/8	14-1/8 22-1/8 -	7-5/8 7-5/8 7-3/4	3 3 5-1/8	- 11 -	46 46 46	15 15 15	34@1,465# 10@1,668# 10@1,600#	
	94'	GLCSLX1000-8 (S or AL)-94	1000	Steel	30'	3	7-7/8	6.5'	23-3/8	24	28-1/8	7-5/8	3	17	54	15	8@1,885#	
	103'	GLC1000-8 (S or AL)-103 GLCS1000-8 (S or AL)-103 AL1000-8-103 GLCSL1000-8 (S or AL)-103	1000 1000 1000 1000	Steel Steel Alum. Steel	6' 20' 20' 25'	3 3 2-5/8 3	7-7/8 7-7/8 7-7/8 7-7/8	6.5' 6.5' 6.5' 6.5'	23-3/8 23-3/8 14-1/8 23-3/8	10-1/8 18 21-7/8 20-7/8	14-1/8 22-1/8 -	7-5/8 7-5/8 7-3/4 7-5/8	3 3 5-1/8 3	- 11 -	54 54 54 54	15 15 15 15	42@1,465# 12@1,668# 12@1,600# 10@1,760#	
	124'	GLCSLX1000-8 (S or AL)-124	1000	Steel	30'	3	7-7/8	6.5'	23-3/8	24	28-1/8	7-5/8	3	17	54	15	10@1,885#	
	10'	11' 6"	GLC1000-10 (S or AL)-11.5 GLCS1000-10 (S or AL)-11.5 AL1000-10-11.5	1000 1000 1000	Steel Steel Alum.	6' 20' 20'	3 3 2-5/8	7-7/8 7-7/8 7-7/8	8' 8' 8'	13-3/8 13-3/8 17-1/2	10 18 21-7/8	18-3/4 22-1/8 -	8-5/8 8-5/8 8-1/4	3 3 5-5/8	11 -	9 9 9	15 15 15	6@1,490# 4@1,693# 4@1,609#
		23'	GLC1000-10 (S or AL)-23 GLCS1000-10 (S or AL)-23 AL1000-10-23	1000 1000 1000	Steel Steel Alum.	6' 20' 20'	3 3 2-5/8	7-7/8 7-7/8 7-7/8	8' 8' 8'	13-3/8 13-3/8 17-1/2	10 18 21-7/8	18-3/4 22-1/8 -	8-5/8 8-5/8 8-1/4	3 3 5-5/8	11 -	9 9 13	15 15 15	10@1,490# 4@1,693# 4@1,609#
28'		GLCSL1000-10 (S or AL)-28	1000	Steel	25'	3	7-7/8	8'	13-3/8	20-7/8	25	8-5/8	3	13-7/8	13	15	4@1,785#	
33'		GLC1000-10 (S or AL)-33 GLCS1000-10 (S or AL)-33 AL1000-10-33	1000 1000 1000	Steel Steel Alum.	6' 20' 20'	3 3 2-5/8	7-7/8 7-7/8 7-7/8	8' 8' 8'	13-3/8 13-3/8 17-1/2	10 18 21-7/8	18-3/4 22-1/8 -	8-5/8 8-5/8 8-1/4	3 3 5-5/8	- 11 -	13 13 19	15 15 15	14@1,490# 6@1,693# 6@1,609#	
34'		GLCSLX1000-10 (S or AL)-34	1000	Steel	30'	3	7-7/8	8'	13-3/8	24	28-1/8	8-5/8	3	17	13	15	4@1,910#	
43'		GLC1000-10 (S or AL)-43 GLCS1000-10 (S or AL)-43 AL1000-10-43	1000 1000 1000	Steel Steel Alum.	6' 20' 20'	3 3 2-5/8	7-7/8 7-7/8 7-7/8	8' 8' 8'	13-3/8 13-3/8 17-1/2	10 18 21-7/8	18-3/4 22-1/8 -	8-5/8 8-5/8 8-1/4	3 3 5-5/8	11 -	19 19 26	15 15 15	18@1,490# 6@1,693# 6@1,609#	
53'		GLC1000-10 (S or AL)-53 GLCS1000-10 (S or AL)-53 AL1000-10-53 GLCSL1000-10 (S or AL)-53	1000 1000 1000 1000	Steel Steel Alum. Steel	6' 20' 20' 25'	3 3 2-5/8 3	7-7/8 7-7/8 7-7/8 7-7/8	8' 8' 8' 8'	13-3/8 13-3/8 17-1/2 13-3/8	10 18 21-7/8 20-7/8	18-3/4 22-1/8 -	8-5/8 8-5/8 8-1/4 8-5/8	3 3 5-5/8 3	- 11 -	19 19 30 19	15 15 15 15	22@1,490# 8@1,693# 8@1,609# 6@1,785#	
63'		GLC1000-10 (S or AL)-63 GLCS1000-10 (S or AL)-63 AL1000-10-63	1000 1000 1000	Steel Steel Alum.	6' 20' 20'	3 3 2-5/8	7-7/8 7-7/8 7-7/8	8' 8' 8'	13-3/8 13-3/8 17-1/2	10 18 21-7/8	18-3/4 22-1/8 -	8-5/8 8-5/8 8-1/4	3 3 5-5/8	- 11 -	26 26 36	15 15 15	26@1,490# 8@1,693# 8@1,609#	
64'		GLCSLX1000-10 (S or AL)-64	1000	Steel	30'	3	7-7/8	8'	23-3/8	24	28-1/8	8-5/8	3	17	36	15	6@1,910#	
78'		GLCSL1000-10 (S or AL)-78	1000	Steel	25'	3	7-7/8	8'	23-3/8	20-7/8	25	8-5/8	3	13-7/8	46	15	8@1,785#	
83'		GLC1000-10 (S or AL)-83 GLCS1000-10 (S or AL)-83 AL1000-10-83	1000 1000 1000	Steel Steel Alum.	6' 20' 20'	3 3 2-5/8	7-7/8 7-7/8 7-7/8	8' 8' 8'	23-3/8 23-3/8 17-1/2	10 18 21-7/8	18-3/4 22-1/8 -	8-5/8 8-5/8 8-1/4	3 3 5-5/8	- 11 -	46 46 46	15 15 15	34@1,490# 10@1,693# 10@1,609#	
94'		GLCSLX1000-10 (S or AL)-94	1000	Steel	30'	3	7-7/8	8'	23-3/8	24	28-1/8	8-5/8	3	17	54	15	8@1,910#	
103'		GLC1000-10 (S or AL)-103 GLCS1000-10 (S or AL)-103 AL1000-10-103 GLCSL1000-10 (S or AL)-103	1000 1000 1000 1000	Steel Steel Alum. Steel	6' 20' 20' 25'	3 3 2-5/8 3	7-7/8 7-7/8 7-7/8 7-7/8	8' 8' 8' 8'	23-3/8 23-3/8 17-1/2 23-3/8	10 18 21-7/8 20-7/8	18-3/4 22-1/8 -	8-5/8 8-5/8 8-1/4 8-5/8	3 3 5-5/8 3	- 11 -	54 54 54 54	15 15 15 15	42@1,490# 12@1,693# 12@1,609# 10@1,785#	
124'		GLCSLX1000-10 (S or AL)-124	1000	Steel	30'	3	7-7/8	8'	23-3/8	24	28-1/8	8-5/8	3	17	54	15	10@1,910#	

*This column provides the total number of support hangers with the corresponding vertical load applied by each support hanger (in pounds) based on the "L1" dimensions shown. Up to a 20" hanger drop will be provided by Gorbel. Additional hanger points or longer drops can be provided at an additional charge.

Gorbel® Work Station Bridge Crane kits include: bridge, runways, hoist trolley, end trucks, end stops, flat wire festooning, festoon gliders (festoon trolleys on steel runway lengths greater than 63' and all aluminum systems), festoon stack-up section, splice joints and hanger brackets. Sway bracing is required on all systems except flush mounted systems (by others). Sway bracing kits are available but are not included in the crane kit.

Dimensions are for reference only and are subject to change without notice.

CEILING MOUNTED WORK STATION BRIDGE CRANES - 1000# CAPACITY

BRIDGE LENGTH (L)	RUNWAY LENGTH	MODEL NUMBER	TRACK SERIES	TRACK MATL.	MAX. L1	BRIDGE										RUNWAY				
						T1	L3	L4	L6	H3	H3A	H4	H2	H1	L7	L8	HANGERS (See Note)*			
15'	23'	GLC1000-15 (S or AL)-23 GLCS1000-15 (S or AL)-23 AL1000-15-23	1000 1000 1000	Steel Steel Alum.	6' 20' 20'	3 3 2-5/8	7-7/8 7-7/8 7-7/8	13' 13' 13'	23-3/8 23-3/8 24-1/4	10 18 21-7/8	14-1/8 22-1/8 -	14-1/8 14-1/8 13-1/8	3 3 10-1/2	- 11 -	9 9 13	15 15 15	10@1.520# 6@1.723# 4@1.630#			
	28'	GLCSL1000-15 (S or AL)-28	1000	Steel	25'	3	7-7/8	13'	23-3/8	20-7/8	25	14-1/8	3	13-7/8	13	15	4@1.816#			
	33'	GLC1000-15 (S or AL)-33 GLCS1000-15 (S or AL)-33 AL1000-15-33	1000 1000 1000	Steel Steel Alum.	6' 20' 20'	3 3 2-5/8	7-7/8 7-7/8 7-7/8	13' 13' 13'	23-3/8 23-3/8 24-1/4	10 18 21-7/8	14-1/8 22-1/8 -	14-1/8 14-1/8 13-1/8	3 3 10-1/2	- 11 -	13 13 19	15 15 15	14@1.520# 6@1.723# 6@1.630#			
	34'	GLCSLX1000-15 (S or AL)-34	1000	Steel	30'	3	7-7/8	13'	23-3/8	24	28-1/8	14-1/8	3	17	13	15	4@1.941#			
	43'	GLC1000-15 (S or AL)-43 GLCS1000-15 (S or AL)-43 AL1000-15-43	1000 1000 1000	Steel Steel Alum.	6' 20' 20'	3 3 2-5/8	7-7/8 7-7/8 7-7/8	13' 13' 13'	23-3/8 23-3/8 24-1/4	10 18 21-7/8	14-1/8 22-1/8 -	14-1/8 14-1/8 13-1/8	3 3 10-1/2	- 11 -	19 19 26	15 15 15	18@1.520# 6@1.723# 6@1.630#			
	53'	GLC1000-15 (S or AL)-53 GLCS1000-15 (S or AL)-53 AL1000-15-53 GLCSL1000-15 (S or AL)-53	1000 1000 1000 1000	Steel Steel Alum. Steel	6' 20' 20' 25'	3 3 2-5/8 3	7-7/8 7-7/8 7-7/8 7-7/8	13' 13' 13' 13'	23-3/8 23-3/8 24-1/4 23-3/8	10 18 21-7/8 20-7/8	14-1/8 22-1/8 21-7/8 25	14-1/8 14-1/8 13-1/8 14-1/8	3 3 10-1/2 3	- 11 -	19 19 30 19	15 15 15 15	22@1.520# 8@1.723# 8@1.630# 6@1.816#			
	63'	GLC1000-15 (S or AL)-63 GLCS1000-15 (S or AL)-63 AL1000-15-63	1000 1000 1000	Steel Steel Alum.	6' 20' 20'	3 3 2-5/8	7-7/8 7-7/8 7-7/8	13' 13' 13'	23-3/8 23-3/8 24-1/4	10 18 21-7/8	14-1/8 22-1/8 -	14-1/8 14-1/8 13-1/8	3 3 10-1/2	- 11 -	26 26 36	15 15 15	26@1.520# 8@1.723# 8@1.630#			
	64'	GLCSLX1000-15 (S or AL)-64	1000	Steel	30'	3	7-7/8	13'	24-1/4	24	28-1/8	14-1/8	3	17	36	15	6@1.941#			
	78'	GLCSL1000-15 (S or AL)-78	1000	Steel	25'	3	7-7/8	13'	24-1/4	20-7/8	25	14-1/8	3	13-7/8	46	15	8@1.816#			
	83'	GLC1000-15 (S or AL)-83 GLCS1000-15 (S or AL)-83 AL1000-15-83	1000 1000 1000	Steel Steel Alum.	6' 20' 20'	3 3 2-5/8	7-7/8 7-7/8 7-7/8	13' 13' 13'	24-1/4 24-1/4 24-1/4	10 18 21-7/8	14-1/8 22-1/8 -	14-1/8 14-1/8 13-1/8	3 3 10-1/2	- 11 -	46 46 46	15 15 15	34@1.520# 10@1.723# 10@1.630#			
	94'	GLCSLX1000-15 (S or AL)-94	1000	Steel	30'	3	7-7/8	13'	24-1/4	24	28-1/8	14-1/8	3	17	54	15	8@1.941#			
	103'	GLC1000-15 (S or AL)-103 GLCS1000-15 (S or AL)-103 AL1000-15-103 GLCSL1000-15 (S or AL)-103	1000 1000 1000 1000	Steel Steel Alum. Steel	6' 20' 20' 25'	3 3 2-5/8 3	7-7/8 7-7/8 7-7/8 7-7/8	13' 13' 13' 13'	24-1/4 24-1/4 24-1/4 20-7/8	10 18 21-7/8 20-7/8	14-1/8 22-1/8 21-7/8 25	14-1/8 14-1/8 13-1/8 14-1/8	3 3 10-1/2 3	- 11 -	54 54 54 54	15 15 15 15	42@1.520# 12@1.723# 12@1.630# 10@1.816#			
	124'	GLCSLX1000-15 (S or AL)-124	1000	Steel	30'	3	7-7/8	13'	24-1/4	24	28-1/8	14-1/8	3	17	54	15	10@1.941#			
	20'	23'	GLC1000-20 (S or AL)-23 GLCS1000-20 (S or AL)-23 AL1000-20-23	1000 1000 1000	Steel Steel Alum.	6' 20' 20'	3 3 2-5/8	7-7/8 7-7/8 7-7/8	18' 18' 18'	23-3/8 23-3/8 27-5/8	10 18 21-7/8	14-1/8 22-1/8 -	14-1/8 14-1/8 13-1/8	3 3 10-1/2	- 11 -	9 9 13	15 15 15	10@1.550# 4@1.754# 4@1.650#		
28'		GLCSL1000-20 (S or AL)-28	1000	Steel	25'	3	7-7/8	18'	23-3/8	20-7/8	25	14-1/8	3	13-7/8	13	15	4@1.846#			
33'		GLC1000-20 (S or AL)-33 GLCS1000-20 (S or AL)-33 AL1000-20-33	1000 1000 1000	Steel Steel Alum.	6' 20' 20'	3 3 2-5/8	7-7/8 7-7/8 7-7/8	18' 18' 18'	23-3/8 23-3/8 27-5/8	10 18 21-7/8	14-1/8 22-1/8 -	14-1/8 14-1/8 13-1/8	3 3 10-1/2	- 11 -	13 13 19	15 15 15	14@1.550# 6@1.754# 6@1.650#			
34'		GLCSLX1000-20 (S or AL)-34	1000	Steel	30'	3	7-7/8	18'	23-3/8	24	28-1/8	14-1/8	3	17	13	15	4@1.971#			
43'		GLC1000-20 (S or AL)-43 GLCS1000-20 (S or AL)-43 AL1000-20-43	1000 1000 1000	Steel Steel Alum.	6' 20' 20'	3 3 2-5/8	7-7/8 7-7/8 7-7/8	18' 18' 18'	23-3/8 23-3/8 27-5/8	10 18 21-7/8	14-1/8 22-1/8 -	14-1/8 14-1/8 13-1/8	3 3 10-1/2	- 11 -	19 19 26	15 15 15	18@1.550# 6@1.754# 6@1.650#			
53'		GLC1000-20 (S or AL)-53 GLCS1000-20 (S or AL)-53 AL1000-20-53 GLCSL1000-20 (S or AL)-53	1000 1000 1000 1000	Steel Steel Alum. Steel	6' 20' 20' 25'	3 3 2-5/8 3	7-7/8 7-7/8 7-7/8 7-7/8	18' 18' 18' 18'	23-3/8 23-3/8 27-5/8 23-3/8	10 18 21-7/8 20-7/8	14-1/8 22-1/8 21-7/8 25	14-1/8 14-1/8 13-1/8 14-1/8	3 3 10-1/2 3	- 11 -	19 19 30 19	15 15 15 15	22@1.550# 8@1.754# 8@1.650# 6@1.846#			
63'		GLC1000-20 (S or AL)-63 GLCS1000-20 (S or AL)-63 AL1000-20-63	1000 1000 1000	Steel Steel Alum.	6' 20' 20'	3 3 2-5/8	7-7/8 7-7/8 7-7/8	18' 18' 18'	23-3/8 23-3/8 27-5/8	10 18 21-7/8	14-1/8 22-1/8 -	14-1/8 14-1/8 13-1/8	3 3 10-1/2	- 11 -	26 26 36	15 15 15	26@1.550# 8@1.754# 8@1.650#			
64'		GLCSLX1000-20 (S or AL)-64	1000	Steel	30'	3	7-7/8	18'	27-5/8	24	28-1/8	14-1/8	3	17	36	15	6@1.971#			
78'		GLCSL1000-20 (S or AL)-78	1000	Steel	25'	3	7-7/8	18'	27-5/8	20-7/8	25	14-1/8	3	13-7/8	46	15	8@1.846#			
83'		GLC1000-20 (S or AL)-83 GLCS1000-20 (S or AL)-83 AL1000-20-83	1000 1000 1000	Steel Steel Alum.	6' 20' 20'	3 3 2-5/8	7-7/8 7-7/8 7-7/8	18' 18' 18'	27-5/8 27-5/8 27-5/8	10 18 21-7/8	14-1/8 22-1/8 -	14-1/8 14-1/8 13-1/8	3 3 10-1/2	- 11 -	46 46 46	15 15 15	34@1.550# 10@1.754# 10@1.650#			
94'		GLCSLX1000-20 (S or AL)-94	1000	Steel	30'	3	7-7/8	18'	27-5/8	24	28-1/8	14-1/8	3	17	54	15	8@1.971#			
103'		GLC1000-20 (S or AL)-103 GLCS1000-20 (S or AL)-103 AL1000-20-103 GLCSL1000-20 (S or AL)-103	1000 1000 1000 1000	Steel Steel Alum. Steel	6' 20' 20' 25'	3 3 2-5/8 3	7-7/8 7-7/8 7-7/8 7-7/8	18' 18' 18' 18'	27-5/8 27-5/8 27-5/8 20-7/8	10 18 21-7/8 20-7/8	14-1/8 22-1/8 21-7/8 25	14-1/8 14-1/8 13-1/8 14-1/8	3 3 10-1/2 3	- 11 -	54 54 54 54	15 15 15 15	42@1.550# 12@1.754# 12@1.650# 10@1.846#			
124'		GLCSLX1000-20 (S or AL)-124	1000	Steel	30'	3	7-7/8	18'	27-5/8	24	28-1/8	14-1/8	3	17	54	15	10@1.971#			

*This column provides the total number of support hangers with the corresponding vertical load applied by each support hanger (in pounds) based on the "L1" dimensions shown. Up to a 20" hanger drop will be provided by Gorbel. Additional hanger points or longer drops can be provided at an additional charge.

Gorbel® Work Station Bridge Crane kits include: bridge, runways, hoist trolley, end trucks, end stops, flat wire festooning, festoon gliders (festoon trolleys on steel runway lengths greater than 63' and all aluminum systems), festoon stack-up section, splice joints and hanger brackets. Sway bracing is required on all systems except flush mounted systems (by others). Sway bracing kits are available but are not included in the crane kit.

Dimensions are for reference only and are subject to change without notice.

CEILING MOUNTED WORK STATION BRIDGE CRANES - 1000# CAPACITY

BRIDGE LENGTH (L)	RUNWAY LENGTH	MODEL NUMBER	TRACK SERIES	TRACK MATL.	MAX. L1	BRIDGE								RUNWAY				
						T1	L3	L4	L6	H3	H3A	H4	H2	H1	L7	L8	HANGERS (See Note)*	
						in	in	ft	in	in	in	in	in	in	in	in		
23'	23'	GLC1000-23 (S or AL)-23 GLCS1000-23 (S or AL)-23 AL1000-23-23	1000 1000 1000	Steel Steel Alum.	6' 20' 20'	3 3 2-5/8	7-7/8 7-7/8 7-7/8	21' 21' 20'	23-3/8 23-3/8 31	10 18 21-7/8	14-1/8 22-1/8 -	14-1/8 14-1/8 13-1/8	3 3 10-1/2	- 11 -	9 9 13	15 15 15	10@1.569# 4@1.772# 4@1.663#	
	28'	GLCSL1000-23 (S or AL)-28	1000	Steel	25'	3	7-7/8	21'	23-3/8	20-7/8	25	14-1/8	3	13-7/8	13	15	4@1.864#	
	33'	GLC1000-23 (S or AL)-33 GLCS1000-23 (S or AL)-33 AL1000-23-33	1000 1000 1000	Steel Steel Alum.	6' 20' 20'	3 3 2-5/8	7-7/8 7-7/8 7-7/8	21' 21' 20'	23-3/8 23-3/8 31	10 18 21-7/8	14-1/8 22-1/8 -	14-1/8 14-1/8 13-1/8	3 3 10-1/2	- 11 -	13 13 19	15 15 15	14@1.569# 6@1.772# 6@1.663#	
	34'	GLCSLX1000-23 (S or AL)-34	1000	Steel	30'	3	7-7/8	21'	23-3/8	24	28-1/8	14-1/8	3	17	13	15	4@1.989#	
	43'	GLC1000-23 (S or AL)-43 GLCS1000-23 (S or AL)-43 AL1000-23-43	1000 1000 1000	Steel Steel Alum.	6' 20' 20'	3 3 2-5/8	7-7/8 7-7/8 7-7/8	21' 21' 20'	23-3/8 23-3/8 31	10 18 21-7/8	14-1/8 22-1/8 -	14-1/8 14-1/8 13-1/8	3 3 10-1/2	- 11 -	19 19 26	15 15 15	18@1.569# 6@1.772# 6@1.663#	
	53'	GLC1000-23 (S or AL)-53 GLCS1000-23 (S or AL)-53 AL1000-23-53 GLCSL1000-23 (S or AL)-53	1000 1000 1000 1000	Steel Steel Alum. Steel	6' 20' 20' 25'	3 3 2-5/8 3	7-7/8 7-7/8 7-7/8 7-7/8	21' 21' 20' 21'	23-3/8 23-3/8 31 23-3/8	10 18 21-7/8 20-7/8	14-1/8 22-1/8 -	14-1/8 14-1/8 13-1/8	3 3 10-1/2 3	- 11 -	19 19 30 19	15 15 15 15	22@1.569# 8@1.772# 8@1.663# 6@1.864#	
	63'	GLC1000-23 (S or AL)-63 GLCS1000-23 (S or AL)-63 AL1000-23-63	1000 1000 1000	Steel Steel Alum.	6' 20' 20'	3 3 2-5/8	7-7/8 7-7/8 7-7/8	21' 21' 20'	23-3/8 23-3/8 31	10 18 21-7/8	14-1/8 22-1/8 -	14-1/8 14-1/8 13-1/8	3 3 10-1/2	- 11 -	26 26 36	15 15 15	26@1.569# 6@1.772# 8@1.663#	
	64'	GLCSLX1000-23 (S or AL)-64	1000	Steel	30'	3	7-7/8	21'	31	24	28-1/8	14-1/8	3	17	36	15	6@1.989#	
	78'	GLCSL1000-23 (S or AL)-78	1000	Steel	25'	3	7-7/8	21'	31	20-7/8	25	14-1/8	3	13-7/8	46	15	8@1.864#	
	83'	GLC1000-23 (S or AL)-83 GLCS1000-23 (S or AL)-83 AL1000-23-83	1000 1000 1000	Steel Steel Alum.	6' 20' 20'	3 3 2-5/8	7-7/8 7-7/8 7-7/8	21' 21' 20'	31 31 31	10 18 21-7/8	14-1/8 22-1/8 -	14-1/8 14-1/8 13-1/8	3 3 10-1/2	- 11 -	46 46 46	15 15 15	10@1.569# 10@1.772# 10@1.663#	
	94'	GLCSLX1000-23 (S or AL)-94	1000	Steel	30'	3	7-7/8	21'	31	24	28-1/8	14-1/8	3	17	54	15	8@1.989#	
	103'	GLC1000-23 (S or AL)-103 GLCS1000-23 (S or AL)-103 AL1000-23-103 GLCSL1000-23 (S or AL)-103	1000 1000 1000 1000	Steel Steel Alum. Steel	6' 20' 20' 25'	3 3 2-5/8 3	7-7/8 7-7/8 7-7/8 7-7/8	21' 21' 20' 21'	31 31 31 31	10 18 21-7/8 20-7/8	14-1/8 22-1/8 -	14-1/8 14-1/8 13-1/8	3 3 10-1/2 3	- 11 -	54 54 54 54	15 15 15 15	42@1.569# 12@1.772# 12@1.663# 10@1.864#	
	124'	GLCSLX1000-23 (S or AL)-124	1000	Steel	30'	3	7-7/8	21'	31	24	28-1/8	14-1/8	3	17	54	15	8@1.989#	
	28'	23'	GLC1000-28 (S or AL)-23 GLCS1000-28 (S or AL)-23 AL1000-28-23	1000 1000 1000	Steel Steel Alum.	6' 20' 20'	3 3 2-5/8	7-7/8 7-7/8 7-7/8	25' 25' 25'	33-3/8 33-3/8 37-3/4	12-1/4 20-3/8 23-1/2	15-3/4 23-5/8 -	17 17 -	3 11 -	9 9 13	24-7/8 24-7/8 24-7/8	15 15 15	10@1.594# 4@1.772# 4@1.663#
28'		GLCSL1000-28 (S or AL)-28	1000	Steel	25'	3	7-7/8	25'	33-3/8	23-1/4	26-1/2	17	3	13-7/8	13	24-7/8	4@1.904#	
33'		GLC1000-28 (S or AL)-33 GLCS1000-28 (S or AL)-33 AL1000-28-33	1000 1000 1000	Steel Steel Alum.	6' 20' 20'	3 3 2-5/8	7-7/8 7-7/8 7-7/8	25' 25' 25'	33-3/8 33-3/8 37-3/4	12-1/4 20-3/8 23-1/2	15-3/4 23-5/8 -	17 17 -	3 11 -	13 13 19	24-7/8 24-7/8 24-7/8	15 15 15	14@1.594# 6@1.797# 6@1.663#	
34'		GLCSLX1000-28 (S or AL)-34	1000	Steel	30'	3	7-7/8	25'	33-3/8	26-3/8	29-5/8	17	3	17	13	24-7/8	4@2.029#	
43'		GLC1000-28 (S or AL)-43 GLCS1000-28 (S or AL)-43 AL1000-28-43	1000 1000 1000	Steel Steel Alum.	6' 20' 20'	3 3 2-5/8	7-7/8 7-7/8 7-7/8	25' 25' 25'	33-3/8 33-3/8 37-3/4	12-1/4 20-3/8 23-1/2	15-3/4 23-5/8 -	17 17 -	3 11 -	19 19 26	24-7/8 24-7/8 24-7/8	15 15 15	18@1.594# 6@1.797# 6@1.663#	
53'		GLC1000-28 (S or AL)-53 GLCS1000-28 (S or AL)-53 AL1000-28-53 GLCSL1000-28 (S or AL)-53	1000 1000 1000 1000	Steel Steel Alum. Steel	6' 20' 20' 25'	3 3 2-5/8 3	7-7/8 7-7/8 7-7/8 7-7/8	25' 25' 25' 25'	33-3/8 33-3/8 37-3/4 33-3/8	12-1/4 20-3/8 23-1/2 23-1/4	15-3/4 23-5/8 -	17 17 -	3 11 -	19 19 30 30	24-7/8 24-7/8 24-7/8 24-7/8	15 15 15 15	22@1.594# 8@1.797# 8@1.663# 6@1.904#	
63'		GLC1000-28 (S or AL)-63 GLCS1000-28 (S or AL)-63 AL1000-28-63	1000 1000 1000	Steel Steel Alum.	6' 20' 20'	3 3 2-5/8	7-7/8 7-7/8 7-7/8	25' 25' 25'	33-3/8 33-3/8 37-3/4	12-1/4 20-3/8 23-1/2	15-3/4 23-5/8 -	17 17 -	3 11 -	26 26 36	24-7/8 24-7/8 24-7/8	15 15 15	26@1.594# 10@1.797# 8@1.663#	
64'		GLCSLX1000-28 (S or AL)-64	1000	Steel	30'	3	7-7/8	25'	37-3/4	26-3/8	29-5/8	17	3	17	36	24-7/8	6@2.029#	
78'		GLCSL1000-28 (S or AL)-78	1000	Steel	25'	3	7-7/8	25'	37-3/4	23-1/4	26-1/2	17	3	13-7/8	46	24-7/8	8@1.904#	
83'		GLC1000-28 (S or AL)-83 GLCS1000-28 (S or AL)-83 AL1000-28-83	1000 1000 1000	Steel Steel Alum.	6' 20' 20'	3 3 2-5/8	7-7/8 7-7/8 7-7/8	25' 25' 25'	37-3/4 37-3/4 37-3/4	12-1/4 20-3/8 23-1/2	15-3/4 23-5/8 -	17 17 -	3 11 -	46 46 46	24-7/8 24-7/8 24-7/8	15 15 15	34@1.594# 10@1.663# 10@1.797#	
94'		GLCSLX1000-28 (S or AL)-94	1000	Steel	30'	3	7-7/8	25'	37-3/4	26-3/8	29-5/8	17	3	17	54	24-7/8	8@2.029#	
103'		GLC1000-28 (S or AL)-103 GLCS1000-28 (S or AL)-103 AL1000-23-103 GLCSL1000-28 (S or AL)-103	1000 1000 1000 1000	Steel Steel Alum. Steel	6' 20' 20' 25'	3 3 2-5/8 3	7-7/8 7-7/8 7-7/8 7-7/8	25' 25' 25' 25'	37-3/4 37-3/4 37-3/4 37-3/4	12-1/4 20-3/8 23-1/2 23-1/4	15-3/4 23-5/8 -	17 17 -	3 11 -	54 54 54 54	24-7/8 24-7/8 24-7/8 24-7/8	15 15 15 15	42@1.594# 12@1.797# 12@1.663# 10@1.904#	
124'		GLCSLX1000-28 (S or AL)-124	1000	Steel	30'	3	7-7/8	25'	37-3/4	26-3/8	29-5/8	17	3	17	54	24-7/8	10@2.029#	

*This column provides the total number of support hangers with the corresponding vertical load applied by each support hanger (in pounds) based on the "L1" dimensions shown. Up to a 20" hanger drop will be provided by Gorbel. Additional hanger points or longer drops can be provided at an additional charge.

Gorbel® Work Station Bridge Crane kits include: bridge, runways, hoist trolley, end trucks, end stops, flat wire festooning, festoon gliders (festoon trolleys on steel runway lengths greater than 63' and all aluminum systems), festoon stack-up section, splice joints and hanger brackets. Sway bracing is required on all systems except flush mounted systems (by others). Sway bracing kits are available but are not included in the crane kit.

Dimensions are for reference only and are subject to change without notice.

CEILING MOUNTED WORK STATION BRIDGE CRANES - 1000# CAPACITY

BRIDGE LENGTH (L)	RUNWAY LENGTH	MODEL NUMBER	TRACK SERIES	TRACK MATL.	MAX. L1	BRIDGE								RUNWAY				
						T1	L3	L4	L6	H3	H3A	H4	H2	H1	L7	L8	HANGERS	
						in	in	ft	in	in	in	in	in	in	in	in	(See Note)*	
34'	28'	GLCSL1000-34 (S or AL)-28	1000	Steel	25'	3	7-7/8	30'	39-3/8	23-1/4	26-1/2	20-1/8	3	13-7/8	13	24-7/8	4@1.968#	
	33'	GLC1000-34 (S or AL)-33	1000	Steel	6'	3	7-7/8	30'	39-3/8	12-1/4	14-1/8	20-1/8	3	-	13	24-7/8	14@1.646#	
		GLCS1000-34 (S or AL)-33 AL1000-34-33	1000 1000	Steel Alum.	20' 20'	3 2-5/8	7-7/8 7-7/8	30' 30'	39-3/8 44-1/2	20-3/8 23-1/2	23-5/8 -	20-1/8 16-3/4	3 14-1/8	11 -	13 19	24-7/8 24-7/8	6@1.848# 6@1.663#	
	34'	GLCSLX1000-34 (S or AL)-34	1000	Steel	30'	3	7-7/8	30'	39-3/8	26-3/8	29-5/8	20-1/8	3	17	13	24-7/8	4@2.093#	
	43'	GLC1000-34 (S or AL)-43	1000	Steel	6'	3	7-7/8	30'	39-3/8	12-1/4	14-1/8	20-1/8	3	-	19	24-7/8	18@1.646#	
		GLCS1000-34 (S or AL)-43 AL1000-34-43	1000 1000	Steel Alum.	20' 20'	3 2-5/8	7-7/8 7-7/8	30' 30'	39-3/8 44-1/2	20-3/8 23-1/2	23-5/8 -	20-1/8 16-3/4	3 14-1/8	11 -	19 26	24-7/8 24-7/8	6@1.848# 6@1.663#	
	53'	GLC1000-34 (S or AL)-53	1000	Steel	6'	3	7-7/8	30'	39-3/8	12-1/4	14-1/8	20-1/8	3	-	19	24-7/8	22@1.646#	
		GLCS1000-34 (S or AL)-53	1000	Steel	20'	3	7-7/8	30'	39-3/8	20-3/8	23-5/8	20-1/8	3	11	19	24-7/8	8@1.848#	
		GLCSL1000-34 (S or AL)-53	1000	Steel	20'	2-5/8	7-7/8	30'	44-1/2	23-1/2	-	16-3/4	14-1/8	-	30	24-7/8	8@1.663#	
	63'	GLC1000-34 (S or AL)-63	1000	Steel	25'	3	7-7/8	30'	39-3/8	23-1/4	26-1/2	20-1/8	3	13-7/8	19	24-7/8	6@1.968#	
		GLCS1000-34 (S or AL)-63	1000	Steel	6'	3	7-7/8	30'	39-3/8	12-1/4	14-1/8	20-1/8	3	-	26	24-7/8	26@1.646#	
		AL1000-34-63	1000	Alum.	20'	2-5/8	7-7/8	30'	44-1/2	23-1/2	-	16-3/4	14-1/8	11	26	24-7/8	8@1.848#	
	64'	GLCSLX1000-34 (S or AL)-64	1000	Steel	20'	3	7-7/8	30'	44-1/2	26-3/8	29-5/8	20-1/8	3	17	36	24-7/8	6@2.093#	
	78'	GLCSL1000-34 (S or AL)-78	1000	Steel	30'	3	7-7/8	30'	44-1/2	26-3/8	29-5/8	20-1/8	3	13-7/8	46	24-7/8	8@1.968#	
	83'	GLC1000-34 (S or AL)-83	1000	Steel	25'	3	7-7/8	30'	44-1/2	23-1/4	26-1/2	20-1/8	3	-	46	24-7/8	34@1.646#	
		GLCS1000-34 (S or AL)-83 AL1000-34-83	1000 1000	Steel Alum.	20' 20'	3 2-5/8	7-7/8 7-7/8	30' 30'	44-1/2 44-1/2	20-3/8 23-1/2	23-5/8 -	20-1/8 16-3/4	3 14-1/8	11 -	46 46	24-7/8 24-7/8	10@1.848# 10@1.663#	
94'	GLCSLX1000-34 (S or AL)-94	1000	Steel	20'	3	7-7/8	30'	44-1/2	26-3/8	29-5/8	20-1/8	3	17	54	24-7/8	8@2.093#		
103'	GLC1000-34 (S or AL)-103	1000	Steel	6'	3	7-7/8	30'	44-1/2	12-1/4	14-1/8	20-1/8	3	-	54	24-7/8	42@1.646#		
	GLCS1000-34 (S or AL)-103	1000	Steel	20'	3	7-7/8	30'	44-1/2	20-3/8	23-5/8	20-1/8	3	11	54	24-7/8	12@1.848#		
	AL1000-23-103	1000	Alum.	20'	2-5/8	7-7/8	30'	44-1/2	23-1/2	-	16-3/4	14-1/8	-	54	24-7/8	12@1.663#		
124'	GLCSL1000-34 (S or AL)-103	1000	Steel	25'	3	7-7/8	30'	44-1/2	23-1/4	26-1/2	20-1/8	3	13-7/8	54	24-7/8	10@1.968#		
124'	GLCSLX1000-34 (S or AL)-124	1000	Steel	30'	3	7-7/8	30'	44-1/2	26-3/8	29-5/8	20-1/8	3	17	54	24-7/8	10@2.093#		

*This column provides the total number of support hangers with the corresponding vertical load applied by each support hanger (in pounds) based on the "L1" dimensions shown. Up to a 20" hanger drop will be provided by Gorbel. Additional hanger points or longer drops can be provided at an additional charge.

Gorbel® Work Station Bridge Crane kits include: bridge, runways, hoist trolley, end trucks, end stops, flat wire festooning, festoon gliders (festoon trolleys on steel runway lengths greater than 63' and all aluminum systems), festoon stack-up section, splice joints and hanger brackets. Sway bracing is required on all systems except flush mounted systems (by others). Sway bracing kits are available but are not included in the crane kit.

Dimensions are for reference only and are subject to change without notice.

CEILING MOUNTED WORK STATION BRIDGE CRANES - 2000# CAPACITY

BRIDGE LENGTH (L)	RUNWAY LENGTH	MODEL NUMBER	TRACK SERIES	TRACK MATL.	MAX. L1	BRIDGE								RUNWAY				
						T1	L3	L4	L6	H3	H3A	H4	H2	H1	L7	L8	HANGERS (See Note)*	
						in	in	ft	in	in	in	in	in	in	in	in		
8'	11' 6"	GLC2000-8 (S or AL)-11.5 GLCS2000-8 (S or AL)-11.5 AL2000-8-11.5	2000 2000 2000	Steel Steel Alum.	6' 20' 20'	2-7/8 2-7/8 2-5/8	8-1/8 8-1/8 8-1/8	6.5' 6.5' 6.5'	11-1/2 11-1/2 14-1/4	11-1/8 11-1/8 25-3/8	15-3/4 24-1/4 -	7-7/8 7-7/8 8-1/4	3-1/2 3-1/2 5-5/8	- 12 -	9 9 9	16-1/8 16-1/8 17	6@2.894# 4@3.137# 4@3.046#	
	23'	GLC2000-8 (S or AL)-23 GLCS2000-8 (S or AL)-23 AL2000-8-23	2000 2000 2000	Steel Steel Alum.	6' 20' 20'	2-7/8 2-7/8 2-5/8	8-1/8 8-1/8 8-1/8	6.5' 6.5' 6.5'	11-1/2 11-1/2 14-1/4	11-1/8 11-1/8 25-3/8	15-3/4 24-1/4 -	7-7/8 7-7/8 8-1/4	3-1/2 3-1/2 5-5/8	- 12 -	9 9 13	16-1/8 16-1/8 17	10@2.894# 4@3.137# 4@3.046#	
	28'	GLCSL2000-8 (S or AL)-28	2000	Steel	25'	2-7/8	8-1/8	6.5'	11-1/2	23	27-5/8	7-7/8	3-1/2	15-3/8	13	16-1/8	4@3.308#	
	33'	GLC2000-8 (S or AL)-33 GLCS2000-8 (S or AL)-33 AL2000-8-33	2000 2000 2000	Steel Steel Alum.	6' 20' 20'	2-7/8 2-7/8 2-5/8	8-1/8 8-1/8 8-1/8	6.5' 6.5' 6.5'	11-1/2 11-1/2 14-1/4	11-1/8 11-1/8 25-3/8	15-3/4 24-1/4 -	7-7/8 7-7/8 8-1/4	3-1/2 3-1/2 5-5/8	- 12 -	13 13 19	16-1/8 16-1/8 17	14@2.894# 6@3.137# 6@3.046#	
	34'	GLCSLX2000-8 (S or AL)-34	2000	Steel	30'	2-7/8	8-1/8	6.5'	11-1/2	25-5/8	30-1/4	7-7/8	3-1/2	18	13	16-1/8	4@3.402#	
	43'	GLC2000-8 (S or AL)-43 GLCS2000-8 (S or AL)-43 AL2000-8-43	2000 2000 2000	Steel Steel Alum.	6' 20' 20'	2-7/8 2-7/8 2-5/8	8-1/8 8-1/8 8-1/8	6.5' 6.5' 6.5'	11-1/2 11-1/2 14-1/4	11-1/8 11-1/8 25-3/8	15-3/4 24-1/4 -	7-7/8 7-7/8 8-1/4	3-1/2 3-1/2 5-5/8	- 12 -	19 19 26	16-1/8 16-1/8 17	18@2.894# 6@3.137# 6@3.046#	
	53'	GLC2000-8 (S or AL)-53 GLCS2000-8 (S or AL)-53 AL2000-8-53 GLCSL2000-8 (S or AL)-53	2000 2000 2000 2000	Steel Steel Alum. Steel	6' 20' 20' 25'	2-7/8 2-7/8 2-5/8 2-7/8	8-1/8 8-1/8 8-1/8 8-1/8	6.5' 6.5' 6.5' 6.5'	11-1/2 11-1/2 14-1/4 11-1/2	11-1/8 11-1/8 25-3/8 23	15-3/4 24-1/4 - 27-5/8	7-7/8 7-7/8 8-1/4 7-7/8	3-1/2 3-1/2 5-5/8 3-1/2	- 12 -	19 19 30 19	16-1/8 16-1/8 17 16-1/8	22@2.894# 8@3.137# 8@3.046# 6@3.308#	
	63'	GLC2000-8 (S or AL)-63 GLCS2000-8 (S or AL)-63 AL2000-8-63	2000 2000 2000	Steel Steel Alum.	6' 20' 20'	2-7/8 2-7/8 2-5/8	8-1/8 8-1/8 8-1/8	6.5' 6.5' 6.5'	11-1/2 11-1/2 14-1/4	11-1/8 11-1/8 25-3/8	15-3/4 24-1/4 -	7-7/8 7-7/8 8-1/4	3-1/2 3-1/2 5-5/8	- 12 -	26 26 36	16-1/8 16-1/8 17	26@2.894# 8@3.137# 8@3.046#	
	64'	GLCSLX2000-8 (S or AL)-64	2000	Steel	30'	2-7/8	8-1/8	6.5'	24	25-5/8	30-1/4	7-7/8	3-1/2	18	36	16-1/8	6@3.402#	
	78'	GLCSL2000-8 (S or AL)-78	2000	Steel	25'	2-7/8	8-1/8	6.5'	24	23	27-5/8	7-7/8	3-1/2	15-3/8	46	16-1/8	8@3.308#	
	83'	GLC2000-8 (S or AL)-83 GLCS2000-8 (S or AL)-83 AL2000-8-83	2000 2000 2000	Steel Steel Alum.	6' 20' 20'	2-7/8 2-7/8 2-5/8	8-1/8 8-1/8 8-1/8	6.5' 6.5' 6.5'	24 24 14-1/4	11-1/8 11-1/8 25-3/8	15-3/4 24-1/4 -	7-7/8 7-7/8 8-1/4	3-1/2 3-1/2 5-5/8	- 12 -	46 46 46	16-1/8 16-1/8 17	34@2.894# 10@3.137# 10@3.046#	
	94'	GLCSLX2000-8 (S or AL)-94	2000	Steel	30'	2-7/8	8-1/8	6.5'	24	25-5/8	30-1/4	7-7/8	3-1/2	18	54	16-1/8	8@3.402#	
	103'	GLC2000-8 (S or AL)-103 GLCS2000-8 (S or AL)-103 AL2000-8-103 GLCSL2000-8 (S or AL)-103	2000 2000 2000 2000	Steel Steel Alum. Steel	6' 20' 20' 25'	2-7/8 2-7/8 2-5/8 2-7/8	8-1/8 8-1/8 8-1/8 8-1/8	6.5' 6.5' 6.5' 6.5'	24 24 14-1/4 24	11-1/8 11-1/8 25-3/8 23	15-3/4 24-1/4 - 27-5/8	7-7/8 7-7/8 8-1/4 7-7/8	3-1/2 3-1/2 5-5/8 3-1/2	- 12 -	54 54 54 54	16-1/8 16-1/8 17 16-1/8	42@2.894# 12@3.137# 12@3.046# 10@3.308#	
	124'	GLCSLX2000-8 (S or AL)-124	2000	Steel	30'	2-7/8	8-1/8	6.5'	24	25-5/8	30-1/4	7-7/8	3-1/2	18	54	16-1/8	10@3.402#	
10'	11' 6"	GLC2000-10 (S or AL)-11.5 GLCS2000-10 (S or AL)-11.5 AL2000-10-11.5	2000 2000 2000	Steel Steel Alum.	6' 20' 20'	2-7/8 2-7/8 2-5/8	8-1/8 8-1/8 8-1/8	8' 8' 8'	24 24 17-5/8	11-1/8 19-5/8 25-3/8	15-3/4 24-1/4 -	8-7/8 8-7/8 13-5/8	3-1/2 3-1/2 11	- 12 -	9 9 9	16-1/8 16-1/8 17	6@2.903# 4@3.147# 4@3.056#	
	23'	GLC2000-10 (S or AL)-23 GLCS2000-10 (S or AL)-23 AL2000-10-23	2000 2000 2000	Steel Steel Alum.	6' 20' 20'	2-7/8 2-7/8 2-5/8	8-1/8 8-1/8 8-1/8	8' 8' 8'	24 24 17-5/8	11-1/8 19-5/8 25-3/8	15-3/4 24-1/4 -	8-7/8 8-7/8 13-5/8	3-1/2 3-1/2 11	- 12 -	9 9 13	16-1/8 16-1/8 17	10@2.903# 4@3.147# 4@3.056#	
	28'	GLCSL2000-10 (S or AL)-28	2000	Steel	25'	2-7/8	8-1/8	8'	24	23	27-5/8	8-7/8	3-1/2	15-3/8	13	16-1/8	4@3.336#	
	33'	GLC2000-10 (S or AL)-33 GLCS2000-10 (S or AL)-33 AL2000-10-33	2000 2000 2000	Steel Steel Alum.	6' 20' 20'	2-7/8 2-7/8 2-5/8	8-1/8 8-1/8 8-1/8	8' 8' 8'	24 24 17-5/8	11-1/8 19-5/8 25-3/8	15-3/4 24-1/4 -	8-7/8 8-7/8 13-5/8	3-1/2 3-1/2 11	- 12 -	13 13 19	16-1/8 16-1/8 17	14@2.903# 6@3.147# 6@3.056#	
	34'	GLCSLX2000-10 (S or AL)-34	2000	Steel	30'	2-7/8	8-1/8	8'	24	25-5/8	30-1/4	8-7/8	3-1/2	18	13	16-1/8	4@3.435#	
	43'	GLC2000-10 (S or AL)-43 GLCS2000-10 (S or AL)-43 AL2000-10-43	2000 2000 2000	Steel Steel Alum.	6' 20' 20'	2-7/8 2-7/8 2-5/8	8-1/8 8-1/8 8-1/8	8' 8' 8'	24 24 17-5/8	11-1/8 19-5/8 25-3/8	15-3/4 24-1/4 -	8-7/8 8-7/8 13-5/8	3-1/2 3-1/2 11	- 12 -	19 19 26	16-1/8 16-1/8 17	18@2.903# 6@3.147# 6@3.056#	
	53'	GLC2000-10 (S or AL)-53 GLCS2000-10 (S or AL)-53 AL2000-10-53 GLCSL2000-10 (S or AL)-53	2000 2000 2000 2000	Steel Steel Alum. Steel	6' 20' 20' 25'	2-7/8 2-7/8 2-5/8 2-7/8	8-1/8 8-1/8 8-1/8 8-1/8	8' 8' 8' 8'	24 24 17-5/8 24	11-1/8 19-5/8 25-3/8 23	15-3/4 24-1/4 -	8-7/8 8-7/8 13-5/8 8-7/8	3-1/2 3-1/2 11 3-1/2	- 12 -	19 19 30 19	16-1/8 16-1/8 17 16-1/8	22@2.903# 8@3.147# 8@3.056# 6@3.336#	
	63'	GLC2000-10 (S or AL)-63 GLCS2000-10 (S or AL)-63 AL2000-10-63	2000 2000 2000	Steel Steel Alum.	6' 20' 20'	2-7/8 2-7/8 2-5/8	8-1/8 8-1/8 8-1/8	8' 8' 8'	24 24 17-5/8	11-1/8 19-5/8 25-3/8	15-3/4 24-1/4 -	8-7/8 8-7/8 13-5/8	3-1/2 3-1/2 11	- 12 -	26 26 36	16-1/8 16-1/8 17	26@2.903# 8@3.147# 8@3.056#	
	64'	GLCSLX2000-10 (S or AL)-64	2000	Steel	30'	2-7/8	8-1/8	8'	24	25-5/8	30-1/4	8-7/8	3-1/2	18	36	16-1/8	6@3.435#	
	78'	GLCSL2000-10 (S or AL)-78	2000	Steel	25'	2-7/8	8-1/8	8'	24	23	27-5/8	8-7/8	3-1/2	15-3/8	46	16-1/8	8@3.336#	
	83'	GLC2000-10 (S or AL)-83 GLCS2000-10 (S or AL)-83 AL2000-10-83	2000 2000 2000	Steel Steel Alum.	6' 20' 20'	2-7/8 2-7/8 2-5/8	8-1/8 8-1/8 8-1/8	8' 8' 8'	24 24 17-5/8	11-1/8 19-5/8 25-3/8	15-3/4 24-1/4 -	8-7/8 8-7/8 13-5/8	3-1/2 3-1/2 11	- 12 -	46 46 46	16-1/8 16-1/8 17	34@2.903# 10@3.147# 10@3.056#	
	94'	GLCSLX2000-10 (S or AL)-94	2000	Steel	30'	2-7/8	8-1/8	8'	24	25-5/8	30-1/4	8-7/8	3-1/2	18	54	16-1/8	8@3.435#	
	103'	GLC2000-10 (S or AL)-103 GLCS2000-10 (S or AL)-103 AL2000-10-103 GLCSL2000-10 (S or AL)-103	2000 2000 2000 2000	Steel Steel Alum. Steel	6' 20' 20' 25'	2-7/8 2-7/8 2-5/8 2-7/8	8-1/8 8-1/8 8-1/8 8-1/8	8' 8' 8' 8'	24 24 17-5/8 24	11-1/8 19-5/8 25-3/8 23	15-3/4 24-1/4 -	8-7/8 8-7/8 13-5/8 8-7/8	3-1/2 3-1/2 11 3-1/2	- 12 -	54 54 54 54	16-1/8 16-1/8 17 16-1/8	42@2.903# 12@3.147# 12@3.056# 10@3.336#	
	124'	GLCSLX2000-10 (S or AL)-124	2000	Steel	30'	2-7/8	8-1/8	8'	24	25-5/8	30-1/4	8-7/8	3-1/2	18	54	16-1/8	10@3.435#	

*This column provides the total number of support hangers with the corresponding vertical load applied by each support hanger (in pounds) based on the "L1" dimensions shown. Up to a 20" hanger drop will be provided by Gorbel. Additional hanger points or longer drops can be provided at an additional charge.

Gorbel® Work Station Bridge Crane kits include: bridge, runways, hoist trolley, end trucks, end stops, flat wire festooning, festoon gliders (festoon trolleys on steel runway lengths greater than 63' and all aluminum systems), festoon stack-up section, splice joints and hanger brackets. Sway bracing is required on all systems except flush mounted systems (by others). Sway bracing kits are available but are not included in the crane kit.

Dimensions are for reference only and are subject to change without notice.

CEILING MOUNTED WORK STATION BRIDGE CRANES - 2000# CAPACITY

BRIDGE LENGTH (L)	RUNWAY LENGTH	MODEL NUMBER	TRACK SERIES	TRACK MATL.	MAX. L1	BRIDGE								RUNWAY				
						T1	L3	L4	L6	H3	H3A	H4	H2	H1	L7	L8	HANGERS	
						in	in	ft	in	in	in	in	in	in	in	in	(See Note)*	
15'	23'	GLC2000-15 (S or AL)-23 GLCS2000-15 (S or AL)-23 AL2000-15-23	2000 2000 2000	Steel Steel Alum.	6' 20' 20'	2-7/8 2-7/8 2-5/8	8-1/8 8-1/8 8-1/8	13' 13' 13'	24 24 24-3/8	11-1/8 19-5/8 25-3/8	15-3/4 24-1/4 -	14-7/8 24-1/4 13-5/8	3-1/2 3-1/2 11	- 12 -	9 9 13	16-1/8 16-1/8 17	10@2,960# 4@3,203# 4@3,082#	
	28'	GLCSL2000-15 (S or AL)-28	2000	Steel	25'	2-7/8	8-1/8	13'	24	23	27-5/8	14-7/8	3-1/2	15-3/8	13	16-1/8	4@3,382#	
	33'	GLC2000-15 (S or AL)-33 GLCS2000-15 (S or AL)-33 AL2000-15-33	2000 2000 2000	Steel Steel Alum.	6' 20' 20'	2-7/8 2-7/8 2-5/8	8-1/8 8-1/8 8-1/8	13' 13' 13'	24 24 24-3/8	11-1/8 19-5/8 25-3/8	15-3/4 24-1/4 -	14-7/8 24-1/4 13-5/8	3-1/2 3-1/2 11	- 12 -	13 13 19	16-1/8 16-1/8 17	14@2,960# 6@3,203# 6@3,082#	
	34'	GLCSLX2000-15 (S or AL)-34	2000	Steel	30'	2-7/8	8-1/8	13'	24	25-5/8	30-1/4	14-7/8	3-1/2	18	13	16-1/8	4@3,377#	
	43'	GLC2000-15 (S or AL)-43 GLCS2000-15 (S or AL)-43 AL2000-15-43	2000 2000 2000	Steel Steel Alum.	6' 20' 20'	2-7/8 2-7/8 2-5/8	8-1/8 8-1/8 8-1/8	13' 13' 13'	24 24 24-3/8	11-1/8 19-5/8 25-3/8	15-3/4 24-1/4 -	14-7/8 24-1/4 13-5/8	3-1/2 3-1/2 11	- 12 -	19 19 26	16-1/8 16-1/8 17	18@2,960# 6@3,203# 6@3,082#	
	53'	GLC2000-15 (S or AL)-53 GLCS2000-15 (S or AL)-53 AL2000-15-53 GLCSL2000-15 (S or AL)-53	2000 2000 2000 2000	Steel Steel Alum. Steel	6' 20' 20' 25'	2-7/8 2-7/8 2-5/8 2-7/8	8-1/8 8-1/8 8-1/8 8-1/8	13' 13' 13' 13'	24 24 24-3/8 24	11-1/8 19-5/8 25-3/8 23	15-3/4 24-1/4 25-3/8 27-5/8	14-7/8 24-1/4 13-5/8 14-7/8	3-1/2 3-1/2 11 3-1/2	- 12 -	19 19 30 19	16-1/8 16-1/8 17 16-1/8	22@2,960# 8@3,203# 8@3,082# 6@3,382#	
	63'	GLC2000-15 (S or AL)-63 GLCS2000-15 (S or AL)-63 AL2000-15-63	2000 2000 2000	Steel Steel Alum.	6' 20' 20'	2-7/8 2-7/8 2-5/8	8-1/8 8-1/8 8-1/8	13' 13' 13'	24 24 24-3/8	11-1/8 19-5/8 25-3/8	15-3/4 24-1/4 -	14-7/8 24-1/4 13-5/8	3-1/2 3-1/2 11	- 12 -	26 26 36	16-1/8 16-1/8 17	26@2,960# 6@3,203# 8@3,082#	
	64'	GLCSLX2000-15 (S or AL)-64	2000	Steel	30'	2-7/8	8-1/8	13'	24-3/8	25-5/8	30-1/4	14-7/8	3-1/2	18	36	16-1/8	6@3,477#	
	78'	GLCSL2000-15 (S or AL)-78	2000	Steel	25'	2-7/8	8-1/8	13'	24-3/8	23	27-5/8	14-7/8	3-1/2	15-3/8	46	16-1/8	8@3,382#	
	83'	GLC2000-15 (S or AL)-83 GLCS2000-15 (S or AL)-83 AL2000-15-83	2000 2000 2000	Steel Steel Alum.	6' 20' 20'	2-7/8 2-7/8 2-5/8	8-1/8 8-1/8 8-1/8	13' 13' 13'	24-3/8 24-3/8 24-3/8	11-1/8 19-5/8 25-3/8	15-3/4 24-1/4 -	14-7/8 24-1/4 13-5/8	3-1/2 3-1/2 11	- 12 -	46 46 46	16-1/8 16-1/8 17	34@2,960# 10@3,203# 10@3,082#	
	94'	GLCSLX2000-15 (S or AL)-94	2000	Steel	30'	2-7/8	8-1/8	13'	24-3/8	25-5/8	30-1/4	14-7/8	3-1/2	18	54	16-1/8	8@3,477#	
	103'	GLC2000-15 (S or AL)-103 GLCS2000-15 (S or AL)-103 AL2000-15-103 GLCSL2000-15 (S or AL)-103	2000 2000 2000 2000	Steel Steel Alum. Steel	6' 20' 20' 25'	2-7/8 2-7/8 2-5/8 2-7/8	8-1/8 8-1/8 8-1/8 8-1/8	13' 13' 13' 13'	24-3/8 24-3/8 24-3/8 24-3/8	11-1/8 19-5/8 25-3/8 23	15-3/4 24-1/4 25-3/8 27-5/8	14-7/8 24-1/4 13-5/8 14-7/8	3-1/2 3-1/2 11 3-1/2	- 12 -	54 54 54 54	16-1/8 16-1/8 17 16-1/8	42@2,960# 12@3,203# 12@3,082# 10@3,382#	
	124'	GLCSLX2000-15 (S or AL)-124	2000	Steel	30'	2-7/8	8-1/8	13'	24-3/8	25-5/8	30-1/4	14-7/8	3-1/2	18	54	16-1/8	10@3,477#	
	20'	23'	GLC2000-20 (S or AL)-23 GLCS2000-20 (S or AL)-23 AL2000-20-23	2000 2000 2000	Steel Steel Alum.	6' 20' 20'	2-7/8 2-7/8 2-5/8	8-1/8 8-1/8 8-1/8	18' 18' 18'	24 24 27-3/4	11-1/8 19-5/8 25-3/8	15-3/4 24-1/4 -	14-7/8 24-1/4 13-1/8	3-1/2 3-1/2 13-1/8	- 12 -	9 9 13	16-1/8 16-1/8 17	10@2,973# 4@3,217# 4@3,107#
28'		GLCSL2000-20 (S or AL)-28	2000	Steel	25'	2-7/8	8-1/8	18'	24	23	27-5/8	14-7/8	3-1/2	15-3/8	13	16-1/8	4@3,424#	
33'		GLC2000-20 (S or AL)-33 GLCS2000-20 (S or AL)-33 AL2000-20-33	2000 2000 2000	Steel Steel Alum.	6' 20' 20'	2-7/8 2-7/8 2-5/8	8-1/8 8-1/8 8-1/8	18' 18' 18'	24 24 27-3/4	11-1/8 19-5/8 25-3/8	15-3/4 24-1/4 -	14-7/8 24-1/4 13-5/8	3-1/2 3-1/2 11	- 12 -	13 13 19	16-1/8 16-1/8 17	14@2,973# 6@3,217# 6@3,107#	
34'		GLCSLX2000-20 (S or AL)-34	2000	Steel	30'	2-7/8	8-1/8	18'	24	25-5/8	30-1/4	14-7/8	3-1/2	18	13	16-1/8	4@3,518#	
43'		GLC2000-20 (S or AL)-43 GLCS2000-20 (S or AL)-43 AL2000-20-43	2000 2000 2000	Steel Steel Alum.	6' 20' 20'	2-7/8 2-7/8 2-5/8	8-1/8 8-1/8 8-1/8	18' 18' 18'	24 24 27-3/4	11-1/8 19-5/8 25-3/8	15-3/4 24-1/4 -	14-7/8 24-1/4 13-1/8	3-1/2 3-1/2 13-1/8	- 12 -	19 19 26	16-1/8 16-1/8 17	18@2,973# 6@3,217# 6@3,107#	
53'		GLC2000-20 (S or AL)-53 GLCS2000-20 (S or AL)-53 AL2000-20-53 GLCSL2000-20 (S or AL)-53	2000 2000 2000 2000	Steel Steel Alum. Steel	6' 20' 20' 25'	2-7/8 2-7/8 2-5/8 2-7/8	8-1/8 8-1/8 8-1/8 8-1/8	18' 18' 18' 18'	24 24 27-3/4 24	11-1/8 19-5/8 25-3/8 23	15-3/4 24-1/4 25-3/8 27-5/8	14-7/8 24-1/4 13-1/8 14-7/8	3-1/2 3-1/2 13-1/8 3-1/2	- 12 -	19 19 30 19	16-1/8 16-1/8 17 16-1/8	22@2,973# 8@3,217# 8@3,107# 6@3,424#	
63'		GLC2000-20 (S or AL)-63 GLCS2000-20 (S or AL)-63 AL2000-20-63	2000 2000 2000	Steel Steel Alum.	6' 20' 20'	2-7/8 2-7/8 2-5/8	8-1/8 8-1/8 8-1/8	18' 18' 18'	24 24 27-3/4	11-1/8 19-5/8 25-3/8	15-3/4 24-1/4 -	14-7/8 24-1/4 13-1/8	3-1/2 3-1/2 13-1/8	- 12 -	26 26 36	16-1/8 16-1/8 17	26@2,973# 8@3,217# 8@3,107#	
64'		GLCSLX2000-20 (S or AL)-64	2000	Steel	30'	2-7/8	8-1/8	18'	27-3/4	25-5/8	30-1/4	14-7/8	3-1/2	18	36	16-1/8	6@3,518#	
78'		GLCSL2000-20 (S or AL)-78	2000	Steel	25'	2-7/8	8-1/8	18'	27-3/4	23	27-5/8	14-7/8	3-1/2	15-3/8	46	16-1/8	8@3,424#	
83'		GLC2000-20 (S or AL)-83 GLCS2000-20 (S or AL)-83 AL2000-20-83	2000 2000 2000	Steel Steel Alum.	6' 20' 20'	2-7/8 2-7/8 2-5/8	8-1/8 8-1/8 8-1/8	18' 18' 18'	27-3/4 27-3/4 27-3/4	11-1/8 19-5/8 25-3/8	15-3/4 24-1/4 -	14-7/8 24-1/4 13-1/8	3-1/2 3-1/2 13-1/8	- 12 -	46 46 46	16-1/8 16-1/8 17	34@2,973# 10@3,217# 10@3,107#	
94'		GLCSLX2000-20 (S or AL)-94	2000	Steel	30'	2-7/8	8-1/8	18'	27-3/4	25-5/8	30-1/4	14-7/8	3-1/2	18	54	16-1/8	8@3,518#	
103'		GLC2000-20 (S or AL)-103 GLCS2000-20 (S or AL)-103 AL2000-20-103 GLCSL2000-20 (S or AL)-103	2000 2000 2000 2000	Steel Steel Alum. Steel	6' 20' 20' 25'	2-7/8 2-7/8 2-5/8 2-7/8	8-1/8 8-1/8 8-1/8 8-1/8	18' 18' 18' 18'	27-3/4 27-3/4 27-3/4 27-3/4	11-1/8 19-5/8 25-3/8 23	15-3/4 24-1/4 25-3/8 27-5/8	14-7/8 24-1/4 13-1/8 14-7/8	3-1/2 3-1/2 13-1/8 3-1/2	- 12 -	54 54 54 54	16-1/8 16-1/8 17 16-1/8	42@2,973# 12@3,217# 12@3,107# 10@3,424#	
124'		GLCSLX2000-20 (S or AL)-124	2000	Steel	30'	2-7/8	8-1/8	18'	27-3/4	25-5/8	30-1/4	14-7/8	3-1/2	18	54	16-1/8	10@3,518#	

*This column provides the total number of support hangers with the corresponding vertical load applied by each support hanger (in pounds) based on the "L1" dimensions shown. Up to a 20" hanger drop will be provided by Gorbel. Additional hanger points or longer drops can be provided at an additional charge.

Gorbel® Work Station Bridge Crane kits include: bridge, runways, hoist trolley, end trucks, end stops, flat wire festooning, festoon gliders (festoon trolleys on steel runway lengths greater than 63' and all aluminum systems), festoon stack-up section, splice joints and hanger brackets. Sway bracing is required on all systems except flush mounted systems (by others). Sway bracing kits are available but are not included in the crane kit.

Dimensions are for reference only and are subject to change without notice.

CEILING MOUNTED WORK STATION BRIDGE CRANES - 2000# CAPACITY

BRIDGE LENGTH (L)	RUNWAY LENGTH	MODEL NUMBER	TRACK SERIES	TRACK MATL.	MAX. L1	BRIDGE								RUNWAY			
						T1	L3	L4	L6	H3	H3A	H4	H2	H1	L7	L8	HANGERS (See Note)*
						in	in	ft	in	in	in	in	in	in	in	in	
23'	23'	GLC2000-23 (S or AL)-23 GLCS2000-23 (S or AL)-23 AL2000-23-23	2000 2000 2000	Steel Steel Alum.	6' 20' 20'	2-7/8 2-7/8 2-5/8	8-1/8 8-1/8 8-1/8	21' 21' 20'	24 24 31-1/8	11-1/8 19-5/8 25-3/8	15-3/4 24-1/4 -	14-7/8 14-7/8 15-3/4	3-1/2 3-1/2 13-1/8	- - -	9 9 13	16-1/8 16-1/8 17	10@3,910# 4@3,263# 4@3,123#
	28'	GLCSL2000-23 (S or AL)-28	2000	Steel	25'	2-7/8	8-1/8	21'	24	23	27-5/8	14-7/8	3-1/2	15-3/8	13	16-1/8	4@3,449#
	33'	GLC2000-23 (S or AL)-33 GLCS2000-23 (S or AL)-33 AL2000-23-33	2000 2000 2000	Steel Steel Alum.	6' 20' 20'	2-7/8 2-7/8 2-5/8	8-1/8 8-1/8 8-1/8	21' 21' 20'	24 24 31-1/8	11-1/8 19-5/8 25-3/8	15-3/4 24-1/4 -	14-7/8 14-7/8 15-3/4	3-1/2 3-1/2 13-1/8	- - -	12 13 19	16-1/8 16-1/8 17	14@3,019# 6@3,263# 6@3,123#
	34'	GLCSLX2000-23 (S or AL)-34	2000	Steel	30'	2-7/8	8-1/8	21'	24	25-5/8	30-1/4	14-7/8	3-1/2	18	13	16-1/8	4@3,543#
	43'	GLC2000-23 (S or AL)-43 GLCS2000-23 (S or AL)-43 AL2000-23-43	2000 2000 2000	Steel Steel Alum.	6' 20' 20'	2-7/8 2-7/8 2-5/8	8-1/8 8-1/8 8-1/8	21' 21' 20'	24 24 31-1/8	11-1/8 19-5/8 25-3/8	15-3/4 24-1/4 -	14-7/8 14-7/8 15-3/4	3-1/2 3-1/2 13-1/8	- - -	19 19 26	16-1/8 16-1/8 17	18@3,019# 6@3,263# 6@3,123#
	53'	GLC2000-23 (S or AL)-53 GLCS2000-23 (S or AL)-53 AL2000-23-53 GLCSL2000-23 (S or AL)-53	2000 2000 2000 2000	Steel Steel Alum. Steel	6' 20' 20' 25'	2-7/8 2-7/8 2-5/8 2-7/8	8-1/8 8-1/8 8-1/8 8-1/8	21' 21' 20' 21'	24 24 31-1/8 24	11-1/8 19-5/8 25-3/8 23	15-3/4 24-1/4 -	14-7/8 14-7/8 15-3/4 14-7/8	3-1/2 3-1/2 13-1/8 3-1/2	- - -	19 19 30 19	16-1/8 16-1/8 17 16-1/8	22@3,019# 8@3,263# 8@3,123# 6@3,449#
	63'	GLC2000-23 (S or AL)-63 GLCS2000-23 (S or AL)-63 AL2000-23-63	2000 2000 2000	Steel Steel Alum.	6' 20' 20'	2-7/8 2-7/8 2-5/8	8-1/8 8-1/8 8-1/8	21' 21' 20'	24 24 31-1/8	11-1/8 19-5/8 25-3/8	15-3/4 24-1/4 -	14-7/8 14-7/8 15-3/4	3-1/2 3-1/2 13-1/8	- - -	26 26 36	16-1/8 16-1/8 17	26@3,019# 8@3,263# 8@3,123#
	64'	GLCSLX2000-23 (S or AL)-64	2000	Steel	30'	2-7/8	8-1/8	21'	31-1/8	25-3/8	30-1/4	14-7/8	3-1/2	18	36	16-1/8	6@3,543#
	78'	GLCSL2000-23 (S or AL)-78	2000	Steel	25'	2-7/8	8-1/8	21'	31-1/8	23	27-5/8	14-7/8	3-1/2	15-3/8	46	16-1/8	8@3,449#
	83'	GLC2000-23 (S or AL)-83 GLCS2000-23 (S or AL)-83 AL2000-23-83	2000 2000 2000	Steel Steel Alum.	6' 20' 20'	2-7/8 2-7/8 2-5/8	8-1/8 8-1/8 8-1/8	21' 21' 20'	31-1/8 31-1/8 31-1/8	11-1/8 19-5/8 25-3/8	15-3/4 24-1/4 -	14-7/8 14-7/8 15-3/4	3-1/2 3-1/2 13-1/8	- - -	46 46 46	16-1/8 16-1/8 17	34@3,019# 10@3,263# 10@3,123#
	94'	GLCSLX2000-23 (S or AL)-94	2000	Steel	30'	2-7/8	8-1/8	21'	31-1/8	25-5/8	30-1/4	14-7/8	3-1/2	18	54	16-1/8	8@3,543#
	103'	GLC2000-23 (S or AL)-103 GLCS2000-23 (S or AL)-103 AL2000-23-103 GLCSL2000-23 (S or AL)-103	2000 2000 2000 2000	Steel Steel Alum. Steel	6' 20' 20' 25'	2-7/8 2-7/8 2-5/8 2-7/8	8-1/8 8-1/8 8-1/8 8-1/8	21' 21' 20' 21'	31-1/8 31-1/8 31-1/8 31-1/8	11-1/8 19-5/8 25-3/8 23	15-3/4 24-1/4 -	14-7/8 14-7/8 15-3/4 14-7/8	3-1/2 3-1/2 13-1/8 3-1/2	- - -	54 54 54 54	16-1/8 16-1/8 17 16-1/8	42@3,019# 12@3,263# 12@3,123# 10@3,449#
	124'	GLCSLX2000-23 (S or AL)-124	2000	Steel	30'	2-7/8	8-1/8	21'	31-1/8	25-5/8	30-1/4	14-7/8	3-1/2	18	54	16-1/8	8@3,543#
	28'	23'	GLC2000-28 (S or AL)-23 GLCS2000-28 (S or AL)-23 AL2000-28-23	2000 2000 2000	Steel Steel Alum.	6' 20' 20'	2-7/8 2-7/8 2-5/8	8-1/8 8-1/8 8-1/8	25' 25' 20'	34-1/2 34-1/2 37-7/8	14 22-1/2 26-1/4	17-7/8 26-1/2 -	18-1/4 18-1/4 17-1/4	3-1/2 3-1/2 14-5/8	- - -	9 9 13	33-1/8 33-1/8 33-1/8
28'		GLCSL2000-28 (S or AL)-28	2000	Steel	25'	2-7/8	8-1/8	25'	34-1/2	25-7/8	29-7/8	18-1/4	3-1/2	15-3/8	13	33-1/8	4@3,506#
33'		GLC2000-28 (S or AL)-33 GLCS2000-28 (S or AL)-33 AL2000-28-33	2000 2000 2000	Steel Steel Alum.	6' 20' 20'	2-7/8 2-7/8 2-5/8	8-1/8 8-1/8 8-1/8	25' 25' 20'	34-1/2 34-1/2 37-7/8	14 22-1/2 26-1/4	17-7/8 26-1/2 -	18-1/4 18-1/4 17-1/4	3-1/2 3-1/2 14-5/8	- - -	13 13 19	33-1/8 33-1/8 33-1/8	14@3,092# 6@3,335# 6@3,123#
34'		GLCSLX2000-28 (S or AL)-34	2000	Steel	30'	2-7/8	8-1/8	25'	34-1/2	28-1/2	32-1/2	18-1/4	3-1/2	18	13	33-1/8	4@3,600#
43'		GLC2000-28 (S or AL)-43 GLCS2000-28 (S or AL)-43 AL2000-28-43	2000 2000 2000	Steel Steel Alum.	6' 20' 20'	2-7/8 2-7/8 2-5/8	8-1/8 8-1/8 8-1/8	25' 25' 20'	34-1/2 34-1/2 37-7/8	14 22-1/2 26-1/4	17-7/8 26-1/2 -	18-1/4 18-1/4 17-1/4	3-1/2 3-1/2 14-5/8	- - -	19 19 26	33-1/8 33-1/8 33-1/8	18@3,092# 8@3,335# 6@3,123#
53'		GLC2000-28 (S or AL)-53 GLCS2000-28 (S or AL)-53 AL2000-28-53 GLCSL2000-28 (S or AL)-53	2000 2000 2000 2000	Steel Steel Alum. Steel	6' 20' 20' 25'	2-7/8 2-7/8 2-5/8 2-7/8	8-1/8 8-1/8 8-1/8 8-1/8	25' 25' 20' 25'	34-1/2 34-1/2 37-7/8 34-1/2	14 22-1/2 26-1/4 25-7/8	17-7/8 26-1/2 -	18-1/4 18-1/4 17-1/4 18-1/4	3-1/2 3-1/2 14-5/8 3-1/2	- - -	19 12 30 19	33-1/8 33-1/8 33-1/8 33-1/8	22@3,092# 8@3,335# 8@3,123# 6@3,506#
63'		GLC2000-28 (S or AL)-63 GLCS2000-28 (S or AL)-63 AL2000-28-63	2000 2000 2000	Steel Steel Alum.	6' 20' 20'	2-7/8 2-7/8 2-5/8	8-1/8 8-1/8 8-1/8	25' 25' 20'	34-1/2 34-1/2 37-7/8	14 22-1/2 26-1/4	17-7/8 26-1/2 -	18-1/4 18-1/4 17-1/4	3-1/2 3-1/2 14-5/8	- - -	26 26 36	33-1/8 33-1/8 33-1/8	26@3,092# 8@3,335# 8@3,123#
64'		GLCSLX2000-28 (S or AL)-64	2000	Steel	30'	2-7/8	8-1/8	25'	37-7/8	28-1/2	32-1/2	18-1/4	3-1/2	18	36	33-1/8	6@3,600#
78'		GLCSL2000-28 (S or AL)-78	2000	Steel	25'	2-7/8	8-1/8	25'	37-7/8	25-7/8	29-7/8	18-1/4	3-1/2	15-3/8	46	33-1/8	8@3,506#
83'		GLC2000-28 (S or AL)-83 GLCS2000-28 (S or AL)-83 AL2000-28-83	2000 2000 2000	Steel Steel Alum.	6' 20' 20'	2-7/8 2-7/8 2-5/8	8-1/8 8-1/8 8-1/8	25' 25' 20'	37-7/8 37-7/8 37-7/8	14 22-1/2 26-1/4	17-7/8 26-1/2 -	18-1/4 18-1/4 17-1/4	3-1/2 3-1/2 14-5/8	- - -	46 46 46	33-1/8 33-1/8 33-1/8	34@3,092# 10@3,335# 10@3,123#
94'		GLCSLX2000-28 (S or AL)-94	2000	Steel	30'	2-7/8	8-1/8	25'	37-7/8	28-1/2	32-1/2	18-1/4	3-1/2	18	54	33-1/8	8@3,600#
103'		GLC2000-28 (S or AL)-103 GLCS2000-28 (S or AL)-103 AL2000-28-103 GLCSL2000-28 (S or AL)-103	2000 2000 2000 2000	Steel Steel Alum. Steel	6' 20' 20' 25'	2-7/8 2-7/8 2-5/8 2-7/8	8-1/8 8-1/8 8-1/8 8-1/8	25' 25' 20' 25'	37-7/8 37-7/8 37-7/8 37-7/8	14 22-1/2 26-1/4 25-7/8	17-7/8 26-1/2 -	18-1/4 18-1/4 17-1/4 18-1/4	3-1/2 3-1/2 14-5/8 3-1/2	- - -	54 54 54 54	33-1/8 33-1/8 33-1/8 33-1/8	42@3,092# 12@3,335# 12@3,123# 10@3,506#
124'		GLCSLX2000-28 (S or AL)-124	2000	Steel	30'	2-7/8	8-1/8	25'	37-7/8	28-1/2	32-1/2	18-1/4	3-1/2	18	54	33-1/8	10@3,600#

*This column provides the total number of support hangers with the corresponding vertical load applied by each support hanger (in pounds) based on the "L1" dimensions shown. Up to a 20" hanger drop will be provided by Gorbel. Additional hanger points or longer drops can be provided at an additional charge.

Gorbel® Work Station Bridge Crane kits include: bridge, runways, hoist trolley, end trucks, end stops, flat wire festooning, festoon gliders (festoon trolleys on steel runway lengths greater than 63' and all aluminum systems), festoon stack-up section, splice joints and hanger brackets. Sway bracing is required on all systems except flush mounted systems (by others). Sway bracing kits are available but are not included in the crane kit.

Dimensions are for reference only and are subject to change without notice.

CEILING MOUNTED WORK STATION BRIDGE CRANES - 2000# CAPACITY

BRIDGE LENGTH (L)	RUNWAY LENGTH	MODEL NUMBER	TRACK SERIES	TRACK MATL.	MAX. L1	BRIDGE								RUNWAY				
						T1	L3	L4	L6	H3	H3A	H4	H2	H1	L7	L8	HANGERS (See Note)*	
						in	in	ft	in	in	in	in	in	in	in	in		
34'	28'	GLCSL2000-34 (S or AL)-28	2000	Steel	25'	2-7/8	8-1/8	30'	40-1/2	25-7/8	29-7/8	20-7/8	3-1/2	15-3/8	13	33-1/8	4@3.562#	
	33'	GLC2000-34 (S or AL)-33	2000	Steel	6'	2-7/8	8-1/8	30'	40-1/2	14	17-7/8	20-7/8	3-1/2	-	13	33-1/8	14@3.148#	
		GLCS2000-34 (S or AL)-33 AL2000-34-33	2000 2000	Steel Alum.	20' 20'	2-7/8 2-5/8	8-1/8 8-1/8	30' 20'	40-1/2 44-5/8	22-1/2 26-1/4	26-1/2 -	20-7/8 18-1/8	3-1/2 15-1/2	12 -	13 19	33-1/8 33-1/8	6@3.391# 6@3.123#	
	34'	GLCSLX2000-34 (S or AL)-34	2000	Steel	30'	2-7/8	8-1/8	30'	40-1/2	28-1/2	32-1/2	20-7/8	3-1/2	18	13	33-1/8	4@3.656#	
	43'	GLC2000-34 (S or AL)-43	2000	Steel	6'	2-7/8	8-1/8	30'	40-1/2	14	17-7/8	20-7/8	3-1/2	-	19	33-1/8	18@3.148#	
		GLCS2000-34 (S or AL)-43 AL2000-34-43	2000 2000	Steel Alum.	20' 20'	2-7/8 2-5/8	8-1/8 8-1/8	30' 20'	40-1/2 44-5/8	22-1/2 26-1/4	26-1/2 -	20-7/8 18-1/8	3-1/2 15-1/2	12 -	19 26	33-1/8 33-1/8	6@3.391# 6@3.123#	
	53'	GLC2000-34 (S or AL)-53	2000	Steel	6'	2-7/8	8-1/8	30'	40-1/2	14	17-7/8	20-7/8	3-1/2	-	19	33-1/8	22@3.148#	
		GLCS2000-34 (S or AL)-53	2000	Steel	20'	2-7/8	8-1/8	30'	40-1/2	22-1/2	26-1/2	20-7/8	3-1/2	12	19	33-1/8	8@3.391#	
		GLCSL2000-34 (S or AL)-53	2000	Steel	25'	2-7/8	8-1/8	30'	40-1/2	25-7/8	29-7/8	20-7/8	3-1/2	15-3/8	19	33-1/8	6@3.562#	
	63'	GLC2000-34 (S or AL)-63	2000	Steel	6'	2-7/8	8-1/8	30'	40-1/2	14	17-7/8	20-7/8	3-1/2	-	26	33-1/8	26@3.148#	
		GLCS2000-34 (S or AL)-63 AL2000-34-63	2000 2000	Steel Alum.	20' 20'	2-7/8 2-5/8	8-1/8 8-1/8	30' 20'	40-1/2 44-5/8	22-1/2 26-1/4	26-1/2 -	20-7/8 18-1/8	3-1/2 15-1/2	12 -	26 36	33-1/8 33-1/8	8@3.391# 8@3.123#	
	64'	GLCSLX2000-34 (S or AL)-64	2000	Steel	30'	2-7/8	8-1/8	30'	44-5/8	28-1/2	32-1/2	20-7/8	3-1/2	18	36	33-1/8	6@3.656#	
	78'	GLCSL2000-34 (S or AL)-78	2000	Steel	25'	2-7/8	8-1/8	30'	44-5/8	25-7/8	29-7/8	20-7/8	3-1/2	15-3/8	46	33-1/8	8@3.562#	
	83'	GLC2000-34 (S or AL)-83	2000	Steel	6'	2-7/8	8-1/8	30'	44-5/8	14	17-7/8	20-7/8	3-1/2	-	46	33-1/8	34@3.148#	
GLCS2000-34 (S or AL)-83 AL2000-34-83		2000 2000	Steel Alum.	20' 20'	2-7/8 2-5/8	8-1/8 8-1/8	30' 20'	44-5/8 44-5/8	22-1/2 26-1/4	26-1/2 -	20-7/8 18-1/8	3-1/2 15-1/2	12 -	46 46	33-1/8 33-1/8	10@3.391# 10@3.123#		
94'	GLCSLX2000-34 (S or AL)-94	2000	Steel	30'	2-7/8	8-1/8	30'	44-5/8	28-1/2	32-1/2	20-7/8	3-1/2	18	54	33-1/8	8@3.656#		
103'	GLC2000-34 (S or AL)-103	2000	Steel	6'	2-7/8	8-1/8	30'	44-5/8	14	17-7/8	20-7/8	3-1/2	-	54	33-1/8	42@3.148#		
	GLCS2000-34 (S or AL)-103	2000	Steel	20'	2-7/8	8-1/8	30'	44-5/8	22-1/2	26-1/2	20-7/8	3-1/2	12	54	33-1/8	12@3.391#		
	AL2000-34-103	2000	Alum.	20'	2-5/8	8-1/8	20'	44-5/8	26-1/4	-	18-1/8	15-1/2	-	54	33-1/8	12@3.123#		
124'	GLCSL2000-34 (S or AL)-103	2000	Steel	25'	2-7/8	8-1/8	30'	44-5/8	25-7/8	29-7/8	20-7/8	3-1/2	15-3/8	54	33-1/8	10@3.562#		
124'	GLCSLX2000-34 (S or AL)-124	2000	Steel	30'	2-7/8	8-1/8	30'	44-5/8	28-1/2	32-1/2	20-7/8	3-1/2	18	54	33-1/8	10@3.656#		

*This column provides the total number of support hangers with the corresponding vertical load applied by each support hanger (in pounds) based on the "L1" dimensions shown. Up to a 20" hanger drop will be provided by Gorbel. Additional hanger points or longer drops can be provided at an additional charge.

Gorbel® Work Station Bridge Crane kits include: bridge, runways, hoist trolley, end trucks, end stops, flat wire festooning, festoon gliders (festoon trolleys on steel runway lengths greater than 63' and all aluminum systems), festoon stack-up section, splice joints and hanger brackets. Sway bracing is required on all systems except flush mounted systems (by others). Sway bracing kits are available but are not included in the crane kit.

Dimensions are for reference only and are subject to change without notice.

CEILING MOUNTED WORK STATION BRIDGE CRANES - 4000# CAPACITY

BRIDGE LENGTH (L)	RUNWAY LENGTH	MODEL NUMBER	TRACK SERIES	TRACK MATL.	MAX. L1	BRIDGE								RUNWAY				
						T1	L3	L4	L6	H3	H3A	H4	H2	H1	L7	L8	HANGERS	
						in	in	ft	in	in	in	in	in	in	in	in	(See Note)*	
15'	23'	GLC4000-15 (S or AL)-23 GLCS4000-15 (S or AL)-23	4000 4000	Steel Steel	6' 20'	2-7/8 2-7/8	15-1/8 15-1/8	12-1/2' 12-1/2'	38-1/2' 38-1/2'	13-7/8 28-5/8	18-1/4 32-3/4	21-1/8 21-1/8	3-1/2' 3-1/2'	- 18	9 9	33-1/8 33-1/8	10@5,770# 4@6,084#	
	28'	GLCSL4000-15 (S or AL)-28	4000	Steel	25'	2-7/8	15-1/8	12-1/2'	38-1/2'	30-5/8	34-3/4	21-1/8	3-1/2'	20	13	33-1/8	4@6,311#	
	33'	GLC4000-15 (S or AL)-33 GLCS4000-15 (S or AL)-33	4000 4000	Steel Steel	6' 20'	2-7/8 2-7/8	15-1/8 15-1/8	12-1/2' 12-1/2'	38-1/2' 38-1/2'	13-7/8 28-5/8	18-1/4 32-3/4	21-1/8 21-1/8	3-1/2' 3-1/2'	- 18	13 13	33-1/8 33-1/8	14@5,770# 6@6,084#	
	34'	GLCSLX4000-20 (S or AL)-34	4000	Steel	30'	2-7/8	15-1/8	12-1/2'	38-1/2'	32-5/8	36-3/4	21-1/8	3-1/2'	22	13	33-1/8	4@6,556#	
	43'	GLC4000-15 (S or AL)-43 GLCS4000-15 (S or AL)-43	4000 4000	Steel Steel	6' 20'	2-7/8 2-7/8	15-1/8 15-1/8	12-1/2' 12-1/2'	38-1/2' 38-1/2'	13-7/8 28-5/8	18-1/4 32-3/4	21-1/8 21-1/8	3-1/2' 3-1/2'	- 18	19 19	33-1/8 33-1/8	18@5,770# 6@6,084#	
	53'	GLC4000-15 (S or AL)-53 GLCS4000-15 (S or AL)-53 GLCSL4000-15 (S or AL)-53	4000 4000 4000	Steel Steel Steel	6' 20' 25'	2-7/8 2-7/8 2-7/8	15-1/8 15-1/8 15-1/8	12-1/2' 12-1/2' 12-1/2'	38-1/2' 38-1/2' 38-1/2'	13-7/8 28-5/8 30-5/8	18-1/4 32-3/4 34-3/4	21-1/8 21-1/8 21-1/8	3-1/2' 3-1/2' 3-1/2'	- 18 20	19 19 19	33-1/8 33-1/8 33-1/8	22@5,770# 8@6,084# 6@6,311#	
	63'	GLC4000-15 (S or AL)-63 GLCS4000-15 (S or AL)-63	4000 4000	Steel Steel	6' 20'	2-7/8 2-7/8	15-1/8 15-1/8	12-1/2' 12-1/2'	38-1/2' 38-1/2'	13-7/8 28-5/8	18-1/4 32-3/4	21-1/8 21-1/8	3-1/2' 3-1/2'	- 18	26 26	33-1/8 33-1/8	26@5,770# 8@6,084#	
	64'	GLCSLX4000-15 (S or AL)-64	4000	Steel	30'	2-7/8	15-1/8	12-1/2'	38-1/2'	32-5/8	36-3/4	21-1/8	3-1/2'	22	36	33-1/8	6@6,556#	
	78'	GLCSL4000-15 (S or AL)-78	4000	Steel	25'	2-7/8	15-1/8	12-1/2'	38-1/2'	30-5/8	34-3/4	21-1/8	3-1/2'	20	46	33-1/8	8@6,311#	
	83'	GLC4000-15 (S or AL)-83 GLCS4000-15 (S or AL)-83	4000 4000	Steel Steel	6' 20'	2-7/8 2-7/8	15-1/8 15-1/8	12-1/2' 12-1/2'	38-1/2' 38-1/2'	13-7/8 28-5/8	18-1/4 32-3/4	21-1/8 21-1/8	3-1/2' 3-1/2'	- 18	46 46	33-1/8 33-1/8	34@5,770# 10@6,084#	
	94'	GLCSLX4000-15 (S or AL)-94	4000	Steel	30'	2-7/8	15-1/8	12-1/2'	38-1/2'	32-5/8	36-3/4	21-1/8	3-1/2'	22	54	33-1/8	8@6,556#	
	103'	GLC4000-15 (S or AL)-103 GLCS4000-15 (S or AL)-103 GLCSL4000-15 (S or AL)-103	4000 4000 4000	Steel Steel Steel	6' 20' 25'	2-7/8 2-7/8 2-7/8	15-1/8 15-1/8 15-1/8	12-1/2' 12-1/2' 12-1/2'	38-1/2' 38-1/2' 38-1/2'	13-7/8 28-5/8 30-5/8	18-1/4 32-3/4 34-3/4	21-1/8 21-1/8 21-1/8	3-1/2' 3-1/2' 3-1/2'	- 18 20	54 54 54	33-1/8 33-1/8 33-1/8	42@5,770# 12@6,084# 10@6,311#	
124'	GLCSLX4000-15 (S or AL)-124	4000	Steel	30'	2-7/8	15-1/8	12-1/2'	38-1/2'	32-5/8	36-3/4	21-1/8	3-1/2'	22	54	33-1/8	10@6,556#		
20'	23'	GLC4000-20 (S or AL)-23 GLCS4000-20 (S or AL)-23	4000 4000	Steel Steel	6' 20'	2-7/8 2-7/8	15-1/8 15-1/8	17-1/2' 17-1/2'	38-1/2' 38-1/2'	13-7/8 28-5/8	18-1/4 32-3/4	21-1/8 21-1/8	3-1/2' 3-1/2'	- 18	9 9	33-1/8 33-1/8	10@5,816# 4@6,130#	
	28'	GLCSL4000-20 (S or AL)-28	4000	Steel	25'	2-7/8	15-1/8	17-1/2'	38-1/2'	30-5/8	34-3/4	21-1/8	3-1/2'	20	13	33-1/8	4@6,357#	
	33'	GLC4000-20 (S or AL)-33 GLCS4000-20 (S or AL)-33	4000 4000	Steel Steel	6' 20'	2-7/8 2-7/8	15-1/8 15-1/8	17-1/2' 17-1/2'	38-1/2' 38-1/2'	13-7/8 28-5/8	18-1/4 32-3/4	21-1/8 21-1/8	3-1/2' 3-1/2'	- 18	13 13	33-1/8 33-1/8	14@5,816# 10@6,130#	
	34'	GLCSLX4000-20 (S or AL)-34	4000	Steel	30'	2-7/8	15-1/8	17-1/2'	38-1/2'	32-5/8	36-3/4	21-1/8	3-1/2'	22	13	33-1/8	4@6,602#	
	43'	GLC4000-20 (S or AL)-43 GLCS4000-20 (S or AL)-43	4000 4000	Steel Steel	6' 20'	2-7/8 2-7/8	15-1/8 15-1/8	17-1/2' 17-1/2'	38-1/2' 38-1/2'	13-7/8 28-5/8	18-1/4 32-3/4	21-1/8 21-1/8	3-1/2' 3-1/2'	- 18	19 19	33-1/8 33-1/8	18@5,816# 6@6,130#	
	53'	GLC4000-20 (S or AL)-53 GLCS4000-20 (S or AL)-53 GLCSL4000-20 (S or AL)-53	4000 4000 4000	Steel Steel Steel	6' 20' 25'	2-7/8 2-7/8 2-7/8	15-1/8 15-1/8 15-1/8	17-1/2' 17-1/2' 17-1/2'	38-1/2' 38-1/2' 38-1/2'	13-7/8 28-5/8 30-5/8	18-1/4 32-3/4 34-3/4	21-1/8 21-1/8 21-1/8	3-1/2' 3-1/2' 3-1/2'	- 18 20	19 19 19	33-1/8 33-1/8 33-1/8	22@5,816# 8@6,130# 6@6,357#	
	63'	GLC4000-20 (S or AL)-63 GLCS4000-20 (S or AL)-63	4000 4000	Steel Steel	6' 20'	2-7/8 2-7/8	15-1/8 15-1/8	17-1/2' 17-1/2'	38-1/2' 38-1/2'	13-7/8 28-5/8	18-1/4 32-3/4	21-1/8 21-1/8	3-1/2' 3-1/2'	- 18	26 26	33-1/8 33-1/8	26@5,816# 8@6,130#	
	64'	GLCSLX4000-20 (S or AL)-64	4000	Steel	30'	2-7/8	15-1/8	17-1/2'	38-1/2'	32-5/8	36-3/4	21-1/8	3-1/2'	22	36	33-1/8	6@6,602#	
	78'	GLCSL4000-20 (S or AL)-78	4000	Steel	25'	2-7/8	15-1/8	17-1/2'	38-1/2'	30-5/8	34-3/4	21-1/8	3-1/2'	20	46	33-1/8	8@6,357#	
	83'	GLC4000-20 (S or AL)-83 GLCS4000-20 (S or AL)-83	4000 4000	Steel Steel	6' 20'	2-7/8 2-7/8	15-1/8 15-1/8	17-1/2' 17-1/2'	38-1/2' 38-1/2'	13-7/8 28-5/8	18-1/4 32-3/4	21-1/8 21-1/8	3-1/2' 3-1/2'	- 18	46 46	33-1/8 33-1/8	34@5,816# 10@6,130#	
	94'	GLCSLX4000-20 (S or AL)-94	4000	Steel	30'	2-7/8	15-1/8	17-1/2'	38-1/2'	32-5/8	36-3/4	21-1/8	3-1/2'	22	54	33-1/8	8@6,602#	
	103'	GLC4000-20 (S or AL)-103 GLCS4000-20 (S or AL)-103 GLCSL4000-20 (S or AL)-103	4000 4000 4000	Steel Steel Steel	6' 20' 25'	2-7/8 2-7/8 2-7/8	15-1/8 15-1/8 15-1/8	17-1/2' 17-1/2' 17-1/2'	38-1/2' 38-1/2' 38-1/2'	13-7/8 28-5/8 30-5/8	18-1/4 32-3/4 34-3/4	21-1/8 21-1/8 21-1/8	3-1/2' 3-1/2' 3-1/2'	- 18 20	54 54 54	33-1/8 33-1/8 33-1/8	42@5,816# 12@6,130# 10@6,357#	
124'	GLCSLX4000-20 (S or AL)-124	4000	Steel	30'	2-7/8	15-1/8	17-1/2'	38-1/2'	32-5/8	36-3/4	21-1/8	3-1/2'	22	54	33-1/8	10@6,602#		
23'	23'	GLC4000-23 (S or AL)-23 GLCS4000-23 (S or AL)-23	4000 4000	Steel Steel	6' 20'	2-7/8 2-7/8	15-1/8 15-1/8	20-1/2' 20-1/2'	38-1/2' 38-1/2'	13-7/8 28-5/8	18-1/4 32-3/4	21-1/8 21-1/8	3-1/2' 3-1/2'	- 18	9 9	33-1/8 33-1/8	10@5,843# 4@6,158#	
	28'	GLCSL4000-23 (S or AL)-28	4000	Steel	25'	2-7/8	15-1/8	20-1/2'	38-1/2'	30-5/8	34-3/4	21-1/8	3-1/2'	20	13	33-1/8	4@6,385#	
	33'	GLC4000-23 (S or AL)-33 GLCS4000-23 (S or AL)-33	4000 4000	Steel Steel	6' 20'	2-7/8 2-7/8	15-1/8 15-1/8	20-1/2' 20-1/2'	38-1/2' 38-1/2'	13-7/8 28-5/8	18-1/4 32-3/4	21-1/8 21-1/8	3-1/2' 3-1/2'	- 18	13 13	33-1/8 33-1/8	14@5,843# 6@6,158#	
	34'	GLCSLX4000-23 (S or AL)-34	4000	Steel	30'	2-7/8	15-1/8	20-1/2'	38-1/2'	32-5/8	36-3/4	21-1/8	3-1/2'	22	13	33-1/8	4@6,630#	
	43'	GLC4000-23 (S or AL)-43 GLCS4000-23 (S or AL)-43	4000 4000	Steel Steel	6' 20'	2-7/8 2-7/8	15-1/8 15-1/8	20-1/2' 20-1/2'	38-1/2' 38-1/2'	13-7/8 28-5/8	18-1/4 32-3/4	21-1/8 21-1/8	3-1/2' 3-1/2'	- 18	19 19	33-1/8 33-1/8	18@5,843# 6@6,158#	
	53'	GLC4000-23 (S or AL)-53 GLCS4000-23 (S or AL)-53 GLCSL4000-23 (S or AL)-53	4000 4000 4000	Steel Steel Steel	6' 20' 25'	2-7/8 2-7/8 2-7/8	15-1/8 15-1/8 15-1/8	20-1/2' 20-1/2' 20-1/2'	38-1/2' 38-1/2' 38-1/2'	13-7/8 28-5/8 30-5/8	18-1/4 32-3/4 34-3/4	21-1/8 21-1/8 21-1/8	3-1/2' 3-1/2' 3-1/2'	- 18 20	19 19 19	33-1/8 33-1/8 33-1/8	22@5,843# 8@6,158# 6@6,385#	

*This column provides the total number of support hangers with the corresponding vertical load applied by each support hanger (in pounds) based on the "L1" dimensions shown. Up to a 20" hanger drop will be provided by Gorbel. Additional hanger points or longer drops can be provided at an additional charge.

Gorbel® Work Station Bridge Crane kits include: bridge, runways, hoist trolley, end trucks, end stops, flat wire festooning, festoon gliders (festoon trolleys on steel runway lengths greater than 63' and all aluminum systems), festoon stack-up section, splice joints and hanger brackets. Sway bracing is required on all systems except flush mounted systems (by others). Sway bracing kits are available but are not included in the crane kit.

Dimensions are for reference only and are subject to change without notice.

CEILING MOUNTED WORK STATION BRIDGE CRANES - 4000# CAPACITY

BRIDGE LENGTH (L)	RUNWAY LENGTH	MODEL NUMBER	TRACK SERIES	TRACK MATL.	MAX. L1	BRIDGE								RUNWAY				
						T1	L3	L4	L6	H3	H3A	H4	H2	H1	L7	L8	HANGERS	
						in	in	ft	in	in	in	in	in	in	in	in	(See Note)*	
23'	63'	GLC4000-23 (S or AL)-63 GLCS4000-23 (S or AL)-63	4000 4000	Steel Steel	6' 20'	2-7/8 2-7/8	15-1/8 15-1/8	20-1/2' 20-1/2'	38-1/2' 38-1/2'	13-7/8 28-5/8	18-1/4 32-3/4	21-1/8 21-1/8	3-1/2' 3-1/2'	- 18	26 26	33-1/8 33-1/8	26@5,843# 8@6,158#	
	64'	GLCSLX4000-23 (S or AL)-64	4000	Steel	30'	2-7/8	15-1/8	20-1/2'	38-1/2'	32-5/8	36-3/4	21-1/8	3-1/2'	22	36	33-1/8	6@6,630#	
	78'	GLCSL4000-23 (S or AL)-78	4000	Steel	25'	2-7/8	15-1/8	20-1/2'	38-1/2'	30-5/8	34-3/4	21-1/8	3-1/2'	20	46	33-1/8	8@6,385#	
	83'	GLC4000-23 (S or AL)-83 GLCS4000-23 (S or AL)-83	4000 4000	Steel Steel	6' 20'	2-7/8 2-7/8	15-1/8 15-1/8	20-1/2' 20-1/2'	38-1/2' 38-1/2'	13-7/8 28-5/8	18-1/4 32-3/4	21-1/8 21-1/8	3-1/2' 3-1/2'	- 18	46 46	33-1/8 33-1/8	34@5,843# 10@6,158#	
	94'	GLCSLX4000-23 (S or AL)-94	4000	Steel	30'	2-7/8	15-1/8	20-1/2'	38-1/2'	32-5/8	36-3/4	21-1/8	3-1/2'	22	54	33-1/8	8@6,630#	
	103'	GLC4000-23 (S or AL)-103 GLCS4000-23 (S or AL)-103 GLCSL4000-23 (S or AL)-103	4000 4000 4000	Steel Steel Steel	6' 20' 25'	2-7/8 2-7/8 2-7/8	15-1/8 15-1/8 15-1/8	20-1/2' 20-1/2' 20-1/2'	38-1/2' 38-1/2' 38-1/2'	13-7/8 28-5/8 30-5/8	18-1/4 32-3/4 34-3/4	21-1/8 21-1/8 21-1/8	3-1/2' 3-1/2' 3-1/2'	- 18 20	54 54 54	33-1/8 33-1/8 33-1/8	42@5,843# 12@6,158# 10@6,385#	
	124'	GLCSLX4000-23 (S or AL)-124	4000	Steel	30'	2-7/8	15-1/8	20-1/2'	38-1/2'	32-5/8	36-3/4	21-1/8	3-1/2'	22	54	33-1/8	8@6,630#	
28'	23'	GLC4000-28 (S or AL)-23 GLCS4000-28 (S or AL)-23	4000 4000	Steel Steel	6' 20'	2-7/8 2-7/8	15-1/8 15-1/8	25' 25'	41-1/2' 41-1/2'	14 28-5/8	18-1/4 32-3/4	23-1/8 23-1/8	3-1/2' 3-1/2'	- 18	9 9	33-1/8 33-1/8	10@5,952# 4@6,267#	
	28'	GLCSL4000-28 (S or AL)-28	4000	Steel	25'	2-7/8	15-1/8	25'	41-1/2'	30-5/8	34-3/4	23-1/8	3-1/2'	20	13	33-1/8	4@6,494#	
	33'	GLC4000-28 (S or AL)-33 GLCS4000-28 (S or AL)-33	4000 4000	Steel Steel	6' 20'	2-7/8 2-7/8	15-1/8 15-1/8	25' 25'	41-1/2' 41-1/2'	14 28-5/8	18-1/4 32-3/4	23-1/8 23-1/8	3-1/2' 3-1/2'	- 18	13 13	33-1/8 33-1/8	14@5,952# 6@6,267#	
	34'	GLCSLX4000-28 (S or AL)-34	4000	Steel	30'	2-7/8	15-1/8	25'	41-1/2'	32-5/8	36-3/4	23-1/8	3-1/2'	22	13	33-1/8	4@6,739#	
	43'	GLC4000-28 (S or AL)-43 GLCS4000-28 (S or AL)-43	4000 4000	Steel Steel	6' 20'	2-7/8 2-7/8	15-1/8 15-1/8	25' 25'	41-1/2' 41-1/2'	14 28-5/8	18-1/4 32-3/4	23-1/8 23-1/8	3-1/2' 3-1/2'	- 18	19 19	33-1/8 33-1/8	18@5,952# 6@6,267#	
	53'	GLC4000-28 (S or AL)-53 GLCS4000-28 (S or AL)-53 GLCSL4000-28 (S or AL)-53	4000 4000 4000	Steel Steel Steel	6' 20' 25'	2-7/8 2-7/8 2-7/8	15-1/8 15-1/8 15-1/8	25' 25' 25'	41-1/2' 41-1/2' 41-1/2'	14 28-5/8 30-5/8	18-1/4 32-3/4 34-3/4	23-1/8 23-1/8 23-1/8	3-1/2' 3-1/2' 3-1/2'	- 18 20	19 19 19	33-1/8 33-1/8 33-1/8	22@5,952# 8@6,267# 6@6,494#	
	63'	GLC4000-28 (S or AL)-63 GLCS4000-28 (S or AL)-63	4000 4000	Steel Steel	6' 20'	2-7/8 2-7/8	15-1/8 15-1/8	25' 25'	41-1/2' 41-1/2'	14 28-5/8	18-1/4 32-3/4	23-1/8 23-1/8	3-1/2' 3-1/2'	- 18	26 26	33-1/8 33-1/8	26@5,952# 8@6,267#	
	64'	GLCSLX4000-28 (S or AL)-64	4000	Steel	30'	2-7/8	15-1/8	25'	44-7/8	32-5/8	36-3/4	23-1/8	3-1/2'	22	36	33-1/8	6@6,739#	
	78'	GLCSL4000-28 (S or AL)-78	4000	Steel	25'	2-7/8	15-1/8	25'	44-7/8	30-5/8	34-3/4	23-1/8	3-1/2'	20	46	33-1/8	8@6,494#	
	83'	GLC4000-28 (S or AL)-83 GLCS4000-28 (S or AL)-83	4000 4000	Steel Steel	6' 20'	2-7/8 2-7/8	15-1/8 15-1/8	25' 25'	44-7/8 44-7/8	14 28-5/8	18-1/4 32-3/4	23-1/8 23-1/8	3-1/2' 3-1/2'	- 18	46 46	33-1/8 33-1/8	34@5,952# 10@6,267#	
	94'	GLCSLX4000-28 (S or AL)-94	4000	Steel	30'	2-7/8	15-1/8	25'	44-7/8	32-5/8	36-3/4	23-1/8	3-1/2'	22	54	33-1/8	8@6,739#	
	103'	GLC4000-28 (S or AL)-103 GLCS4000-28 (S or AL)-103 GLCSL4000-28 (S or AL)-103	4000 4000 4000	Steel Steel Steel	6' 20' 25'	2-7/8 2-7/8 2-7/8	15-1/8 15-1/8 15-1/8	25' 25' 25'	44-7/8 44-7/8 44-7/8	14 28-5/8 30-5/8	18-1/4 32-3/4 34-3/4	23-1/8 23-1/8 23-1/8	3-1/2' 3-1/2' 3-1/2'	- 18 20	54 54 54	33-1/8 33-1/8 33-1/8	42@5,952# 12@6,267# 10@6,494#	
	124'	GLCSLX4000-28 (S or AL)-124	4000	Steel	30'	2-7/8	15-1/8	25'	44-7/8	32-5/8	36-3/4	23-1/8	3-1/2'	22	54	33-1/8	10@6,739#	
	34'	28'	GLCSL4000-34 (S or AL)-28	4000	Steel	25'	2-7/8	15-1/8	30'	47-1/2'	30-5/8	34-3/4	25-1/8	3-1/2'	20	13	33-1/8	4@6,617#
33'		GLC4000-34 (S or AL)-33 GLCS4000-34 (S or AL)-33	4000 4000	Steel Steel	6' 20'	2-7/8 2-7/8	15-1/8 15-1/8	30' 30'	47-1/2' 47-1/2'	14 28-5/8	18-1/4 32-3/4	25-1/8 25-1/8	3-1/2' 3-1/2'	- 18	13 13	33-1/8 33-1/8	14@6,075# 6@6,389#	
34'		GLCSLX4000-34 (S or AL)-34	4000	Steel	30'	2-7/8	15-1/8	30'	47-1/2'	32-5/8	36-3/4	25-1/8	3-1/2'	22	13	33-1/8	4@6,861#	
43'		GLC4000-34 (S or AL)-43 GLCS4000-34 (S or AL)-43	4000 4000	Steel Steel	6' 20'	2-7/8 2-7/8	15-1/8 15-1/8	30' 30'	47-1/2' 47-1/2'	14 28-5/8	18-1/4 32-3/4	25-1/8 25-1/8	3-1/2' 3-1/2'	- 18	19 19	33-1/8 33-1/8	18@6,075# 6@6,389#	
53'		GLC4000-34 (S or AL)-53 GLCS4000-34 (S or AL)-53 GLCSL4000-34 (S or AL)-53	4000 4000 4000	Steel Steel Steel	6' 20' 25'	2-7/8 2-7/8 2-7/8	15-1/8 15-1/8 15-1/8	30' 30' 30'	47-1/2' 47-1/2' 47-1/2'	14 28-5/8 30-5/8	18-1/4 32-3/4 34-3/4	25-1/8 25-1/8 25-1/8	3-1/2' 3-1/2' 3-1/2'	- 18 20	19 19 19	33-1/8 33-1/8 33-1/8	22@6,075# 8@6,389# 6@6,617#	
63'		GLC4000-34 (S or AL)-63 GLCS4000-34 (S or AL)-63	4000 4000	Steel Steel	6' 20'	2-7/8 2-7/8	15-1/8 15-1/8	30' 30'	47-1/2' 47-1/2'	14 28-5/8	18-1/4 32-3/4	25-1/8 25-1/8	3-1/2' 3-1/2'	- 18	26 26	33-1/8 33-1/8	26@6,075# 8@6,389#	
64'		GLCSLX4000-34 (S or AL)-64	4000	Steel	30'	2-7/8	15-1/8	30'	51-5/8	32-5/8	36-3/4	25-1/8	3-1/2'	22	36	33-1/8	6@6,861#	
78'		GLCSL4000-34 (S or AL)-78	4000	Steel	25'	2-7/8	15-1/8	30'	51-5/8	30-5/8	34-3/4	25-1/8	3-1/2'	20	46	33-1/8	8@6,617#	
83'		GLC4000-34 (S or AL)-83 GLCS4000-34 (S or AL)-83	4000 4000	Steel Steel	6' 20'	2-7/8 2-7/8	15-1/8 15-1/8	30' 30'	51-5/8 51-5/8	14 28-5/8	18-1/4 32-3/4	25-1/8 25-1/8	3-1/2' 3-1/2'	- 18	46 46	33-1/8 33-1/8	34@6,075# 10@6,389#	
94'		GLCSLX4000-34 (S or AL)-94	4000	Steel	30'	2-7/8	15-1/8	30'	51-5/8	32-5/8	36-3/4	25-1/8	3-1/2'	22	54	33-1/8	8@6,861#	
103'		GLC4000-34 (S or AL)-103 GLCS4000-34 (S or AL)-103 GLCSL4000-34 (S or AL)-103	4000 4000 4000	Steel Steel Steel	6' 20' 25'	2-7/8 2-7/8 2-7/8	15-1/8 15-1/8 15-1/8	30' 30' 30'	51-5/8 51-5/8 51-5/8	14 28-5/8 30-5/8	18-1/4 32-3/4 34-3/4	25-1/8 25-1/8 25-1/8	3-1/2' 3-1/2' 3-1/2'	- 18 20	54 54 54	33-1/8 33-1/8 33-1/8	42@6,075# 12@6,389# 10@6,617#	
124'		GLCSLX4000-34 (S or AL)-124	4000	Steel	30'	2-7/8	15-1/8	30'	51-5/8	32-5/8	36-3/4	25-1/8	3-1/2'	22	54	33-1/8	10@6,861#	

*This column provides the total number of support hangers with the corresponding vertical load applied by each support hanger (in pounds) based on the "L1" dimensions shown. Up to a 20" hanger drop will be provided by Gorbel. Additional hanger points or longer drops can be provided at an additional charge.

Gorbel® Work Station Bridge Crane kits include: bridge, runways, hoist trolley, end trucks, end stops, flat wire festooning, festoon gliders (festoon trolleys on steel runway lengths greater than 63' and all aluminum systems), festoon stack-up section, splice joints and hanger brackets. Sway bracing is required on all systems except flush mounted systems (by others). Sway bracing kits are available but are not included in the crane kit.

Dimensions are for reference only and are subject to change without notice.

Monorails

The Solution for True Linear Movement

Gorbel® Work Station Crane Systems can be readily adapted for more sophisticated applications by the addition of extra tracks, curves, switches, and interlocks (transfers) that can be easily integrated into a total system. The pre-engineered modular designs offer the ultimate in flexibility, in layout, and in design for your manufacturing facility.

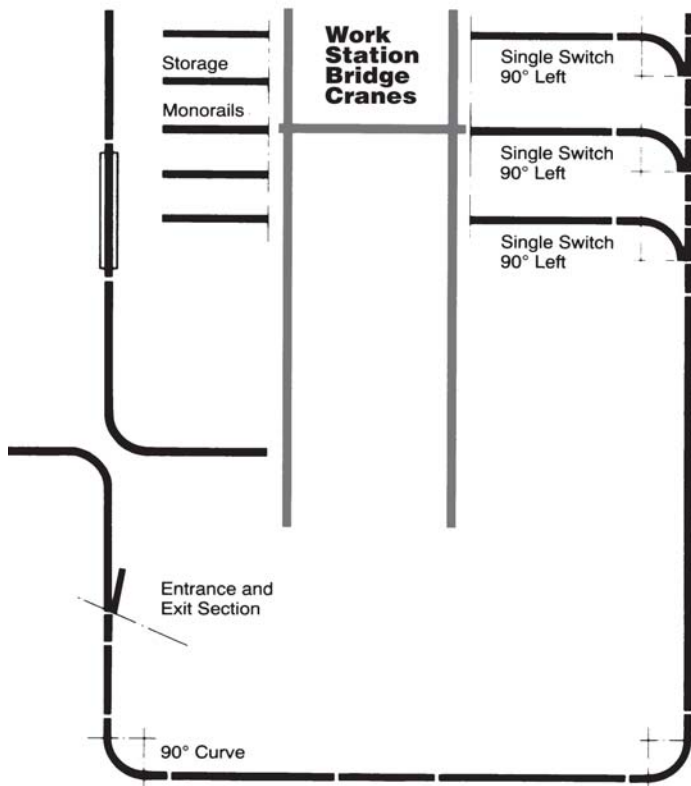

MONORAIL CURVE

The monorail curve is a section of track that is rolled to provide a 90° curve. The curved sections have a straight section which projects beyond the curve. The curve needs to be supported with three hangers, one in the center, one at one end just *outside* the splice joint, and one at the other end just *inside* the splice joint.

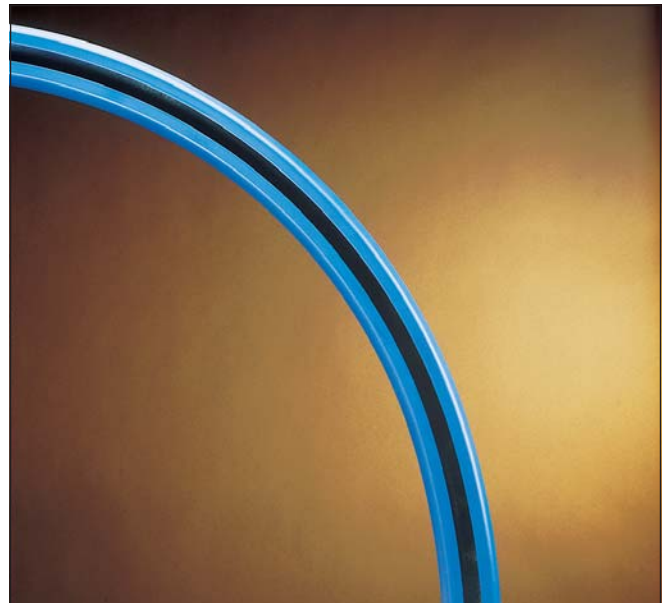

Monorail Curve

INTERLOCKS (TRANSFERS)

Interlocks are used to transfer materials from the working area of the bridge crane to storage monorails, and vice versa. Request the Gorbel® *Interlocks (Transfers)* flyer for additional information.

SWITCHES

Limited sizes of switches can be provided. Please contact the factory for additional information.

CEILING MOUNTED WORK STATION BRIDGE CRANES - MONORAILS

250# CAPACITY	MONORAIL LENGTH (L)	MODEL NUMBER	TRACK SERIES	TRACK MATL.	MAX. L1	T1 in	H1 in	H2 in	L3 in	L7 in	HANGERS (see note)*
	11' 6"	GLM250-11.5	250	Steel	6'	1-1/2	-	1-3/4	5	9	3 @ 365#
		GLMS250-11.5	250	Steel	20'	1-1/2	9	1-3/4	5	9	2 @ 446#
		ALM250-11.5	250	Alum.	20'	2-5/8	-	8	7-1/4	9	2 @ 430#
	23'	GLM250-23	250	Steel	6'	1-1/2	-	1-3/4	5	9	5 @ 365#
		GLMS250-23	250	Steel	20'	1-1/2	9	1-3/4	5	9	2 @ 446#
		ALM250-23	250	Alum.	20'	2-5/8	-	8	7-1/4	13	2 @ 430#
	28'	GLMSL250-28	250	Steel	25'	1-1/2	11	1-3/4	5	9	2 @ 554#
	33'	GLM250-33	250	Steel	6'	1-1/2	-	1-3/4	5	9	7 @ 365#
		GLMS250-33	250	Steel	20'	1-1/2	9	1-3/4	5	9	3 @ 446#
		ALM250-33	250	Alum.	20'	2-5/8	-	8	7-1/4	19	3 @ 430#
	43'	GLM250-43	250	Steel	6'	1-1/2	-	1-3/4	5	13	9 @ 365#
GLMS250-43		250	Steel	20'	1-1/2	9	1-3/4	5	13	3 @ 446#	
ALM250-43		250	Alum.	20'	2-5/8	-	8	7-1/4	26	3 @ 430#	
53'	GLM250-53	250	Steel	6'	1-1/2	-	1-3/4	5	13	11 @ 365#	
	GLMS250-53	250	Steel	20'	1-1/2	9	1-3/4	5	13	4 @ 446#	
	ALM250-53	250	Alum.	20'	2-5/8	-	8	7-1/4	30	4 @ 430#	
	GLMSL250-53	250	Steel	25'	1-1/2	11	1-3/4	5	13	3 @ 554#	
63'	GLM250-63	250	Steel	6'	1-1/2	-	1-3/4	5	19	13 @ 365#	
	GLMS250-63	250	Steel	20'	1-1/2	9	1-3/4	5	19	3 @ 446#	
	ALM250-63	250	Alum.	20'	2-5/8	-	8	7-1/4	36	3 @ 430#	
78'	GLMSL250-78	250	Steel	25'	1-1/2	11	1-3/4	5	46	4 @ 554#	
83'	GLM250-83	250	Steel	6'	1-1/2	-	1-3/4	5	46	17 @ 365#	
	GLMS250-83	250	Steel	20'	1-1/2	9	1-3/4	5	46	5 @ 446#	
	ALM250-83	250	Alum.	20'	2-5/8	-	8	7-1/4	46	5 @ 430#	
103'	GLM250-103	250	Steel	6'	1-1/2	-	1-3/4	5	54	24 @ 365#	
	GLMS250-103	250	Steel	20'	1-1/2	9	1-3/4	5	54	6 @ 446#	
	ALM250-103	250	Alum.	20'	2-5/8	-	8	7-1/4	54	6 @ 430#	
	GLMSL250-103	250	Steel	25'	1-1/2	11	1-3/4	5	54	5 @ 554#	

500# CAPACITY	MONORAIL LENGTH (L)	MODEL NUMBER	TRACK SERIES	TRACK MATL.	MAX. L1	T1 in	H1 in	H2 in	L3 in	L7 in	HANGERS (see note)*
	11' 6"	GLM500-11.5	500	Steel	6'	2-3/4	-	2-3/8	7-1/8	9	3 @ 725#
		GLMS500-11.5	500	Steel	20'	2-3/4	10	2-3/8	7-1/8	9	2 @ 845#
		ALM500-11.5	500	Alum.	20'	2-5/8	-	10	7-1/4	9	2 @ 794#
	23'	GLM500-23	500	Steel	6'	2-3/4	-	2-3/8	7-1/8	9	5 @ 725#
		GLMS500-23	500	Steel	20'	2-3/4	10	2-3/8	7-1/8	9	2 @ 845#
		ALM500-23	500	Alum.	20'	2-5/8	-	10	7-1/4	13	2 @ 794#
	28'	GLMSL500-28	500	Steel	25'	2-3/4	12-3/8	2-3/8	7-1/8	9	2 @ 943#
	33'	GLM500-33	500	Steel	6'	2-3/4	-	2-3/8	7-1/8	9	7 @ 725#
		GLMS500-33	500	Steel	20'	2-3/4	10	2-3/8	7-1/8	9	3 @ 845#
		ALM500-33	500	Alum.	20'	2-5/8	-	10	7-1/4	19	3 @ 794#
	34'	GLMSLX500-34	500	Steel	30'	2-3/4	14-3/8	2-3/8	7-1/8	9	2 @ 991#
43'	GLM500-43	500	Steel	6'	2-3/4	-	2-3/8	7-1/8	13	9 @ 725#	
	GLMS500-43	500	Steel	20'	2-3/4	10	2-3/8	7-1/8	13	3 @ 845#	
	ALM500-43	500	Alum.	20'	2-5/8	-	10	7-1/4	26	3 @ 794#	
53'	GLM500-53	500	Steel	6'	2-3/4	-	2-3/8	7-1/8	13	11 @ 725#	
	GLMS500-53	500	Steel	20'	2-3/4	10	2-3/8	7-1/8	13	4 @ 845#	
	ALM500-53	500	Alum.	20'	2-5/8	-	10	7-1/4	30	4 @ 794#	
	GLMSL500-53	500	Steel	25'	2-3/4	12-3/8	2-3/8	7-1/8	13	3 @ 943#	
63'	GLM500-63	500	Steel	6'	2-3/4	-	2-3/8	7-1/8	19	23 @ 725#	
	GLMS500-63	500	Steel	20'	2-3/4	10	2-3/8	7-1/8	19	4 @ 845#	
	ALM500-63	500	Alum.	20'	2-5/8	-	10	7-1/4	36	4 @ 794#	
64'	GLMSLX500-64	500	Steel	30'	2-3/4	14-3/8	2-3/8	7-1/8	36	3 @ 991#	
78'	GLMSL500-78	500	Steel	25'	2-3/4	12-3/8	2-3/8	7-1/8	46	4 @ 943#	
83'	GLM500-83	500	Steel	6'	2-3/4	-	2-3/8	7-1/8	46	17 @ 725#	
	GLMS500-83	500	Steel	20'	2-3/4	10	2-3/8	7-1/8	46	5 @ 845#	
	ALM500-83	500	Alum.	20'	2-5/8	-	10	7-1/4	46	5 @ 794#	
94'	GLMSLX500-94	500	Steel	30'	2-3/4	14-3/8	2-3/8	7-1/8	54	4 @ 991#	
103'	GLM500-103	500	Steel	6'	2-3/4	-	2-3/8	7-1/8	54	24 @ 725#	
	GLMS500-103	500	Steel	20'	2-3/4	10	2-3/8	7-1/8	54	6 @ 845#	
	ALM500-103	500	Alum.	20'	2-5/8	-	10	7-1/4	54	6 @ 794#	
	GLMSL500-103	500	Steel	25'	2-3/4	12-3/8	2-3/8	7-1/8	54	5 @ 943#	
124'	GLMSLX500-124	500	Steel	30'	2-3/4	14-3/8	2-3/8	7-1/8	54	5 @ 991#	

*This column provides the total number of support hangers with the corresponding vertical load applied by each support hanger (in pounds) based on the "L1" dimensions shown. Up to a 20" hanger drop will be provided by Gorbel. Additional hanger points or longer drops can be provided at an additional charge.

Gorbel® Monorail kits include: monorail track, hoist trolley, end stops, flat wire festooning, festoon gliders (festoon trolleys on steel monorail lengths greater than 63' and all aluminum systems), festoon stack-up section, splice joints and hanger brackets. Sway bracing is required on all systems except flush mounted systems. Sway bracing kits are available but are not included in the crane kit.

Dimensions are for reference only and are subject to change without notice.

CEILING MOUNTED WORK STATION BRIDGE CRANES - MONORAILS

1000# CAPACITY	MONORAIL LENGTH (L)	MODEL NUMBER	TRACK SERIES	TRACK MATL.	MAX. L1	T1 in	H1 in	H2 in	L3 in	L7 in	HANGERS (see note)*
	11' 6"	GLM1000-11.5	1000	Steel	6'	3	-	3	7-7/8	9	3 @ 1,451#
		GLMS1000-11.5	1000	Steel	20'	3	11	3	7-7/8	9	2 @ 1,679#
		ALM1000-11.5	1000	Alum.	20'	2-7/8	-	11	7-7/8	9	2 @ 1,567#
	23'	GLM1000-23	1000	Steel	6'	3	-	3	7-7/8	9	5 @ 1,451#
		GLMS1000-23	1000	Steel	20'	3	11	3	7-7/8	9	2 @ 1,679#
		ALM1000-23	1000	Alum.	20'	2-7/8	-	11	7-7/8	13	2 @ 1,567#
	28'	GLMSL1000-28	1000	Steel	25'	3	13-7/8	3	7-7/8	13	2 @ 1,781#
	33'	GLM1000-33	1000	Steel	6'	3	-	3	7-7/8	13	7 @ 1,451#
		GLMS1000-33	1000	Steel	20'	3	11	3	7-7/8	13	3 @ 1,679#
		ALM1000-33	1000	Alum.	20'	2-7/8	-	11	7-7/8	19	3 @ 1,567#
	34'	GLMSLX1000-34	1000	Steel	30'	3	17	3	7-7/8	13	2 @ 1,915#
43'	GLM1000-43	1000	Steel	6'	3	-	3	7-7/8	19	9 @ 1,451#	
	GLMS1000-43	1000	Steel	20'	3	11	3	7-7/8	19	3 @ 1,679#	
	ALM1000-43	1000	Alum.	20'	2-7/8	-	11	7-7/8	26	3 @ 1,567#	
53'	GLM1000-53	1000	Steel	6'	3	-	3	7-7/8	19	11 @ 1,451#	
	GLMS1000-53	1000	Steel	20'	3	11	3	7-7/8	19	4 @ 1,679#	
	ALM1000-53	1000	Alum.	20'	2-7/8	-	11	7-7/8	30	4 @ 1,567#	
	GLMSL1000-53	1000	Steel	25'	3	13-7/8	3	7-7/8	19	3 @ 1,728#	
63'	GLM1000-63	1000	Steel	6'	3	-	3	7-7/8	26	13 @ 1,451#	
	GLMS1000-63	1000	Steel	20'	3	11	3	7-7/8	26	4 @ 1,679#	
	ALM1000-63	1000	Alum.	20'	2-7/8	-	11	7-7/8	36	4 @ 1,567#	
64'	GLMSLX1000-64	1000	Steel	30'	3	17	3	7-7/8	36	3 @ 1,915#	
78'	GLMSL1000-78	1000	Steel	25'	3	13-7/8	3	7-7/8	46	4 @ 1,781#	
83'	GLM1000-83	1000	Steel	6'	3	-	3	7-7/8	46	17 @ 1,451#	
	GLMS1000-83	1000	Steel	20'	3	11	3	7-7/8	46	5 @ 1,679#	
	ALM1000-83	1000	Alum.	20'	2-7/8	-	11	7-7/8	46	5 @ 1,567#	
94'	GLMSLX1000-94	1000	Steel	30'	3	17	3	7-7/8	54	4 @ 1,915#	
103'	GLM1000-103	1000	Steel	6'	3	-	3	7-7/8	54	24 @ 1,451#	
	GLMS1000-103	1000	Steel	20'	3	11	3	7-7/8	54	6 @ 1,679#	
	ALM1000-103	1000	Alum.	20'	2-7/8	-	11	7-7/8	54	6 @ 1,567#	
	GLMSL1000-103	1000	Steel	25'	3	13-7/8	3	7-7/8	54	5 @ 1,781#	
124'	GLMSLX1000-124	1000	Steel	30'	3	17	3	7-7/8	54	5 @ 1,915#	

2000# CAPACITY	MONORAIL LENGTH (L)	MODEL NUMBER	TRACK SERIES	TRACK MATL.	MAX. L1	T1 in	H1 in	H2 in	L3 in	L7 in	HANGERS (see note)*
	11' 6"	GLM2000-11.5	2000	Steel	6'	2-7/8	-	3-1/2	8-1/8	9	3 @ 2,894#
		GLMS2000-11.5	2000	Steel	20'	2-7/8	12	3-1/2	8-1/8	9	2 @ 3,137#
		ALM2000-11.5	2000	Alum.	20'	2-7/8	-	13-1/4	12-7/8	9	2 @ 3,046#
	23'	GLM2000-23	2000	Steel	6'	2-7/8	-	3-1/2	8-1/8	9	5 @ 2,894#
		GLMS2000-23	2000	Steel	20'	2-7/8	12	3-1/2	8-1/8	9	2 @ 3,137#
		ALM2000-23	2000	Alum.	20'	2-7/8	-	13-1/4	12-7/8	13	2 @ 3,046#
	28'	GLMSL2000-28	2000	Steel	25'	2-7/8	15-3/8	3-1/2	8-1/8	9	2 @ 3,308#
	33'	GLM2000-33	2000	Steel	6'	2-7/8	-	3-1/2	8-1/8	13	7 @ 2,894#
		GLMS2000-33	2000	Steel	20'	2-7/8	12	3-1/2	8-1/8	13	3 @ 3,137#
		ALM2000-33	2000	Alum.	20'	2-7/8	-	13-1/4	12-7/8	19	3 @ 3,046#
	34'	GLMSLX2000-34	2000	Steel	30'	2-7/8	18	3-1/2	8-1/8	13	2 @ 3,402#
43'	GLM2000-43	2000	Steel	6'	2-7/8	-	3-1/2	8-1/8	19	9 @ 2,894#	
	GLMS2000-43	2000	Steel	20'	2-7/8	12	3-1/2	8-1/8	19	3 @ 3,137#	
	ALM2000-43	2000	Alum.	20'	2-7/8	-	13-1/4	12-7/8	26	3 @ 3,046#	
53'	GLM2000-53	2000	Steel	6'	2-7/8	-	3-1/2	8-1/8	19	11 @ 2,894#	
	GLMS2000-53	2000	Steel	20'	2-7/8	12	3-1/2	8-1/8	19	4 @ 3,137#	
	ALM2000-53	2000	Alum.	20'	2-7/8	-	13-1/4	12-7/8	30	4 @ 3,046#	
	GLMSL2000-53	2000	Steel	25'	2-7/8	15-3/8	3-1/2	8-1/8	19	3 @ 3,308#	
63'	GLM2000-63	2000	Steel	6'	2-7/8	-	3-1/2	8-1/8	26	13 @ 2,894#	
	GLMS2000-63	2000	Steel	20'	2-7/8	12	3-1/2	8-1/8	26	4 @ 3,137#	
	ALM2000-63	2000	Alum.	20'	2-7/8	-	13-1/4	12-7/8	36	4 @ 3,046#	
64'	GLMSLX2000-64	2000	Steel	30'	2-7/8	18	3-1/2	8-1/8	36	3 @ 3,402#	
78'	GLMSL2000-78	2000	Steel	25'	2-7/8	15-3/8	3-1/2	8-1/8	46	4 @ 3,308#	
83'	GLM2000-83	2000	Steel	6'	2-7/8	-	3-1/2	8-1/8	46	17 @ 2,894#	
	GLMS2000-83	2000	Steel	20'	2-7/8	12	3-1/2	8-1/8	46	5 @ 3,137#	
	ALM2000-83	2000	Alum.	20'	2-7/8	-	13-1/4	12-7/8	46	5 @ 3,046#	
94'	GLMSLX2000-94	2000	Steel	30'	2-7/8	18	3-1/2	8-1/8	54	4 @ 3,402#	
103'	GLM2000-103	2000	Steel	6'	2-7/8	-	3-1/2	8-1/8	54	24 @ 2,894#	
	GLMS2000-103	2000	Steel	20'	2-7/8	12	3-1/2	8-1/8	54	6 @ 3,137#	
	ALM2000-103	2000	Alum.	20'	2-7/8	-	13-1/4	12-7/8	54	6 @ 3,046#	
	GLMSL2000-103	2000	Steel	25'	2-7/8	15-3/8	3-1/2	8-1/8	54	5 @ 3,308#	
124'	GLMSLX2000-124	2000	Steel	30'	2-7/8	18	3-1/2	8-1/8	54	5 @ 3,402#	

*This column provides the total number of support hangers with the corresponding vertical load applied by each support hanger (in pounds) based on the "L1" dimensions shown. Up to a 20" hanger drop will be provided by Gorbel. Additional hanger points or longer drops can be provided at an additional charge.

Gorbel® Monorail kits include: monorail track, hoist trolley, end stops, flat wire festooning, festoon gliders (festoon trolleys on steel monorail lengths greater than 63' and all aluminum systems), festoon stack-up section, splice joints and hanger brackets. Sway bracing is required on all systems except flush mounted systems. Sway bracing kits are available but are not included in the crane kit.

CEILING MOUNTED WORK STATION BRIDGE CRANES - MONORAILS

4000# CAPACITY	MONORAIL LENGTH (L)	MODEL NUMBER	TRACK SERIES	TRACK MATL.	MAX. L1	T1 in	H1 in	H2 in	L3 in	L7 in	HANGERS (see note)*
	23'	GLM4000-23	4000	Steel	6'	2-7/8	-	3-1/2	15-1/8	9	5 @ 5.664#
		GLMS4000-23	4000	Steel	20'	2-7/8	18	3-1/2	15-1/8	9	2 @ 5.995#
	28'	GLMSL4000-28	4000	Steel	25'	2-7/8	20	3-1/2	15-1/8	13	2 @ 6.093#
		33'	GLM4000-33	4000	Steel	6'	2-7/8	-	3-1/2	15-1/8	13
	GLMS4000-33		4000	Steel	20'	2-7/8	18	3-1/2	15-1/8	13	3 @ 5.995#
	43'	GLM4000-43	4000	Steel	6'	2-7/8	-	3-1/2	15-1/8	19	9 @ 5.664#
		GLMS4000-43	4000	Steel	20'	2-7/8	18	3-1/2	15-1/8	19	3 @ 5.995#
	53'	GLM4000-53	4000	Steel	6'	2-7/8	-	3-1/2	15-1/8	19	11 @ 5.664#
		GLMS4000-53	4000	Steel	20'	2-7/8	18	3-1/2	15-1/8	19	4 @ 5.995#
GLMSL4000-53		4000	Steel	25'	2-7/8	20	3-1/2	15-1/8	19	3 @ 6.093#	
63'	GLM4000-63	4000	Steel	6'	2-7/8	-	3-1/2	15-1/8	26	13 @ 5.664#	
	GLMS4000-63	4000	Steel	20'	2-7/8	18	3-1/2	15-1/8	26	4 @ 5.995#	
78'	GLMSL4000-78	4000	Steel	25'	2-7/8	20	3-1/2	15-1/8	46	4 @ 6.093#	
83'	GLM4000-83	4000	Steel	6'	2-7/8	-	3-1/2	15-1/8	46	17 @ 5.664#	
	GLMS4000-83	4000	Steel	20'	2-7/8	18	3-1/2	15-1/8	46	5 @ 5.995#	
103'	GLM4000-103	4000	Steel	6'	2-7/8	-	3-1/2	15-1/8	54	21 @ 5.664#	
	GLMS4000-103	4000	Steel	20'	2-7/8	18	3-1/2	15-1/8	54	6 @ 5.995#	
	GLMSL4000-103	4000	Steel	25'	2-7/8	20	3-1/2	15-1/8	54	5 @ 6.093#	

*This column provides the total number of support hangers with the corresponding vertical load applied by each support hanger (in pounds) based on the "L1" dimensions shown. Up to a 20" hanger drop will be provided by Gorbel. Additional hanger points or longer drops can be provided at an additional charge.

Gorbel® Monorail kits include: monorail track, hoist trolley, end stops, flat wire festooning, festoon gliders (festoon trolleys on steel monorail lengths greater than 63' and all aluminum systems), festoon stack-up section, splice joints and hanger brackets. Sway bracing is required on all systems except flush mounted systems. Sway bracing kits are available but are not included in the crane kit.

Dimensions are for reference only and are subject to change without notice.

**CEILING MOUNTED WORK STATION
MONORAIL**

**GLM STEEL
MONORAIL**

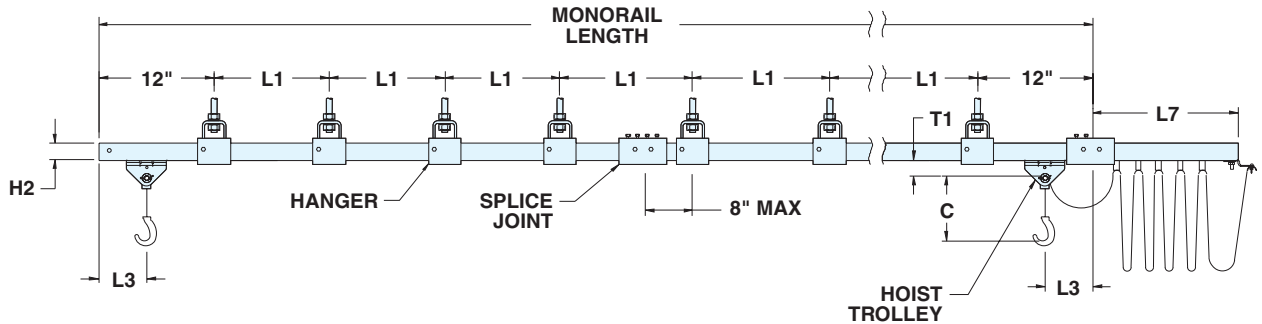

**GLMS, GLMSL,
GLMSLX
STEEL MONORAIL**

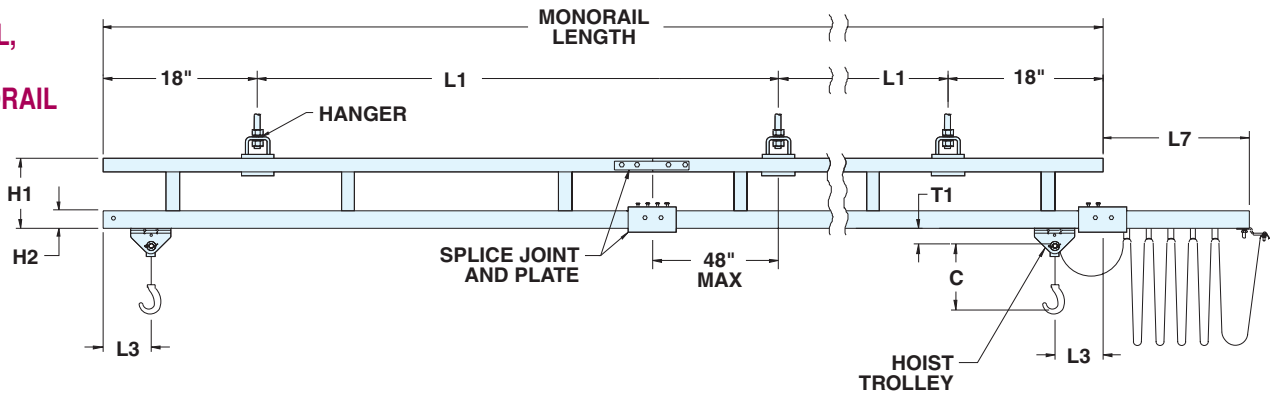

**ALM
ALUMINUM
MONORAIL**

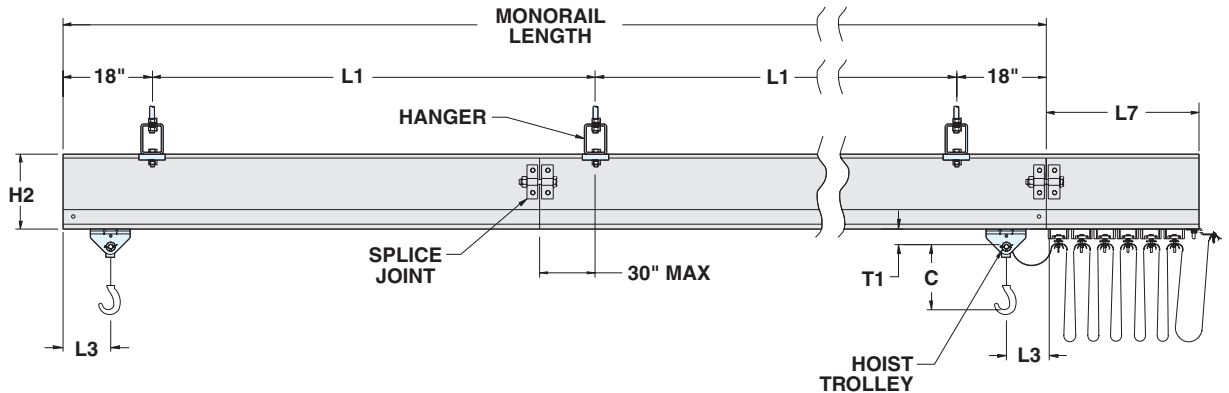

Model Number: _____

Capacity: _____ Pounds

Monorail Length: _____ (OAL)

L1: _____

Are the number of hangers provided sufficient?

(See "HANGERS" column on dimensional chart pages.)

Type of hanger required:

- Standard hanger with up to 20 inch drop.
Support beam flange width _____ inches
- Flush mounted, parallel
Support beam flange width _____ inches
- Flush mounted, perpendicular
Support beam flange width _____ inches
- Special hangers

Note: Sway bracing is required on all systems except flush mounted systems. Sway bracing kits are available but are not included in the crane kit.

C: _____ inches (hoist by others)

GORBEL[®] Monorails include: monorails, hoist trolley, end stops, flat wire festooning, festoon gliders (festoon trolleys on steel monorail lengths greater than 63 feet and all aluminum systems), festoon stack-up section, splice joints and hanger brackets. Additional hanger points or longer drops, in excess of 20 inches, can be provided at an additional cost (hoist and sway bracing by others). Sway bracing kits are available but are not included in the crane kit. Dimension and design details subject to change without notice.

**CEILING MOUNTED WORK STATION MONORAIL
ISOMETRIC VIEW**

**GLM
STEEL MONORAIL**

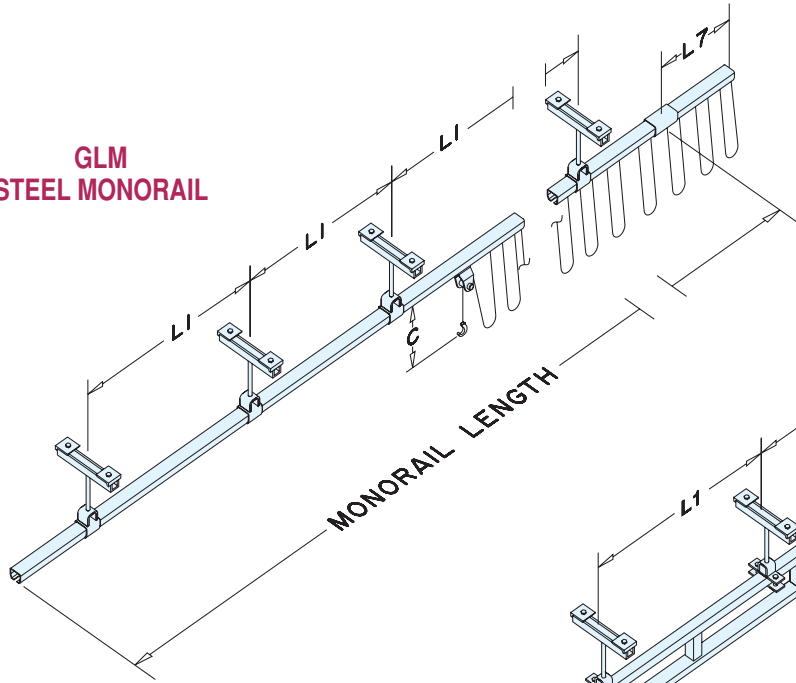

**GLMS(SL,SLX)
STEEL MONORAIL**

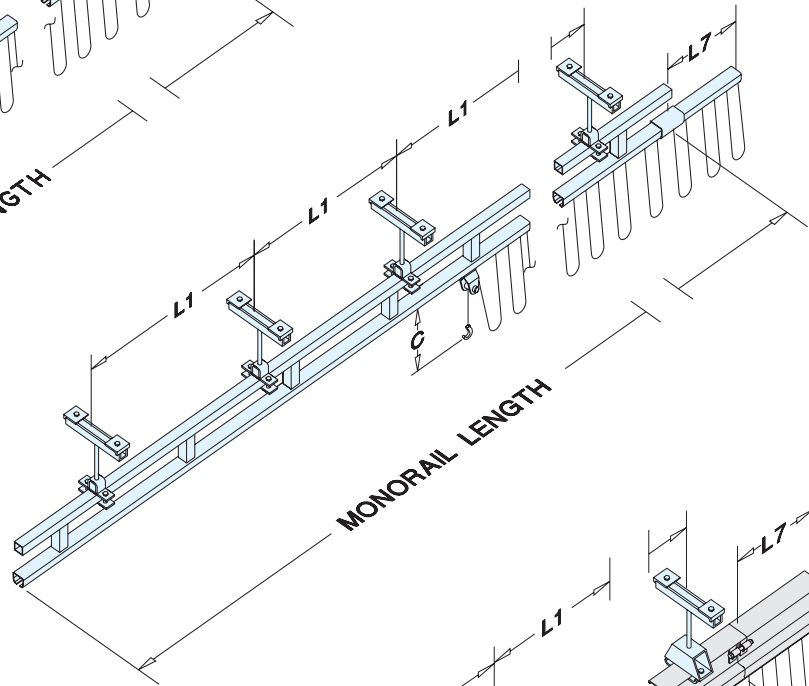

**ALM
ALUMINUM MONORAIL**

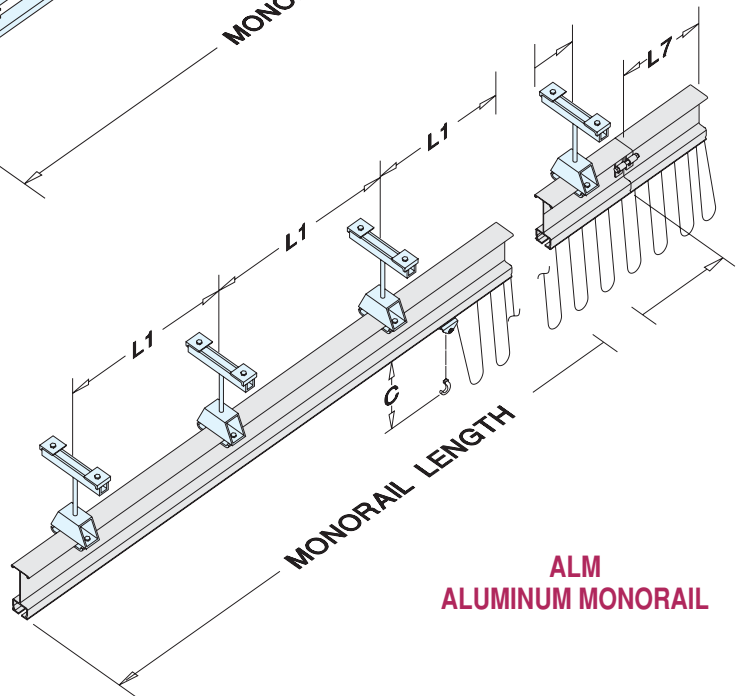

Model Number: _____

Capacity: _____ Pounds

Bridge Length (L): _____ (OAL)

Runway Length: _____ (OAL)

L1: _____ Are the number of hangers provided sufficient?

(See "HANGERS" column on dimensional chart pages.)

Type of hanger required:

- Standard hanger with up to 20 inch drop.
Support beam flange width _____ inches
- Flush mounted, parallel
Support beam flange width _____ inches
- Flush mounted, perpendicular
Support beam flange width _____ inches
- Special hangers

Note: Sway bracing is required on all systems except flush mounted systems. Sway bracing kits are available but are not included in the crane kit.

C: _____ inches (hoist by others)

Gorbel[®] Monorails include: monorails, hoist trolley, end stops, flat wire festooning, festoon gliders (festoon trolleys on steel monorail lengths greater than 63 feet and all aluminum systems), festoon stack-up section, splice joints and hanger brackets. Additional hanger points or longer drops, in excess of 20 inches, can be provided at an additional cost (hoist and sway bracing by others). Sway bracing kits are available but are not included in the crane kit.

Dimension and design details subject to change without notice.

Options When Using Multiple Bridges

What are your options when using multiple bridges? This section addresses the advantages and disadvantages of various multiple bridge system designs.

MIXED CAPACITY SYSTEMS

In mixed capacity systems, each bridge is sized for an individual rated load. Runways, on the other hand, are sized for the *combined* weight of all loads, so they use a heavier track series than any individual bridge.

Advantages:

- There are no “dead” coverage areas (areas with no bridge coverage) along the length of the system, so each bridge can travel the length of the system. (See mixed capacity system diagram)
- There are limited “dead” coverage areas between bridges, so bridges can be used side-by-side. (Compare mixed capacity system diagram with bridge buffer system diagram)
- Bridges weigh less, making the system more ergonomically friendly.

Disadvantages:

- Mixed capacity systems use larger sized runways, so they may cost more than bridge buffer systems or systems that use intermediate stops.

BRIDGE BUFFER SYSTEMS

In bridge buffer systems, bridges are sized for each individual rated load. Runways are sized for the heaviest *individual* load, so the runways are the same size as the largest bridge. Bridges are physically separated by wheeled, movable bridge buffers.

Advantages:

- Bridge buffer systems usually cost less than mixed capacity systems because they typically use smaller sized runways.

Disadvantages:

- The bridge buffers take up space (typically half the distance of the support centers), which creates a moving “dead” space between bridges. (See bridge buffer system diagram)

Note: When using two bridges, the dead space equals half the distance between support centers (L1 from the dimensional charts). When adding a third bridge, the dead space occupied by the additional bridge buffers equals the full distance between support centers.

SYSTEMS WITH INTERMEDIATE STOPS

In systems with intermediate stops, bridges are sized for each individual rated load. Runways are sized for the heaviest *individual* load, so the runways are the same size as the largest bridge. Bridges are physically separated by *internal stops or bumpers*. Extra hangers usually are required to eliminate overload. (See intermediate stops system diagram)

Advantages:

- Systems with intermediate stops use smaller runways, therefore typically cost less than mixed capacity systems.
- There are fewer potential “dead” spots in the system. (Compare intermediate stops system diagram with bridge buffer system diagram)

Disadvantages:

- Each bridge on the system can travel only a portion of the length of the system. (See intermediate stops system diagram)
- Systems with intermediate stops may be more difficult to install, as additional ceiling support points must be available to accommodate the additional hangers required to prevent an overload situation.

MIXED CAPACITY SYSTEM

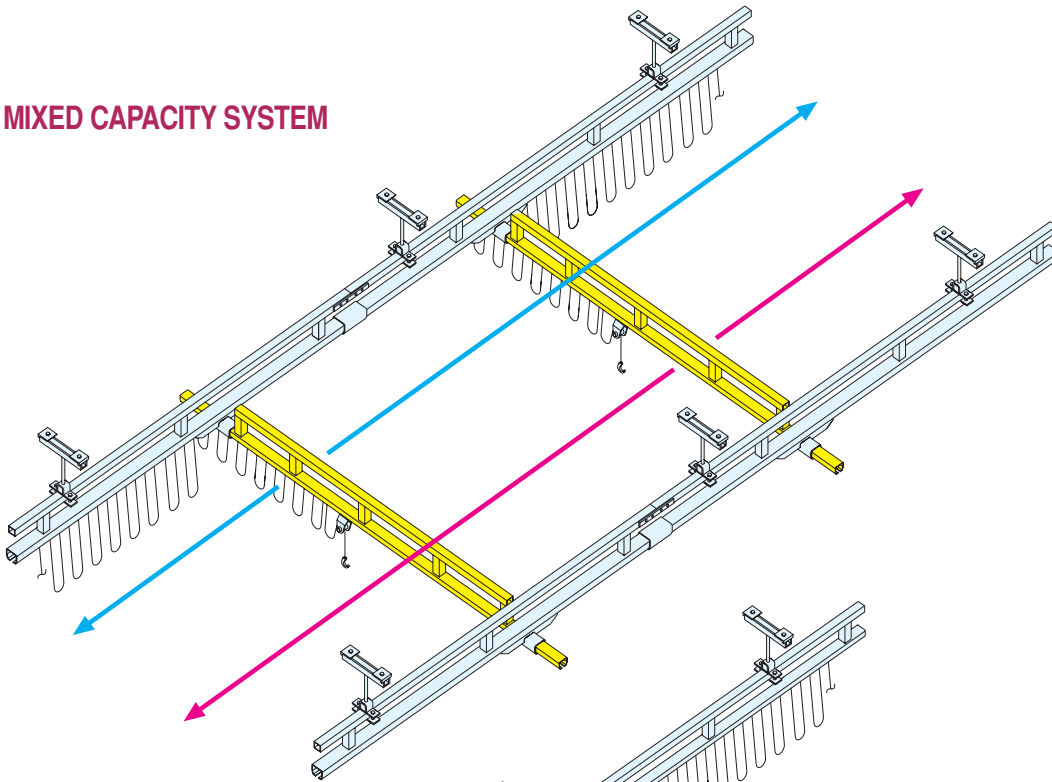

BRIDGE BUFFER SYSTEM

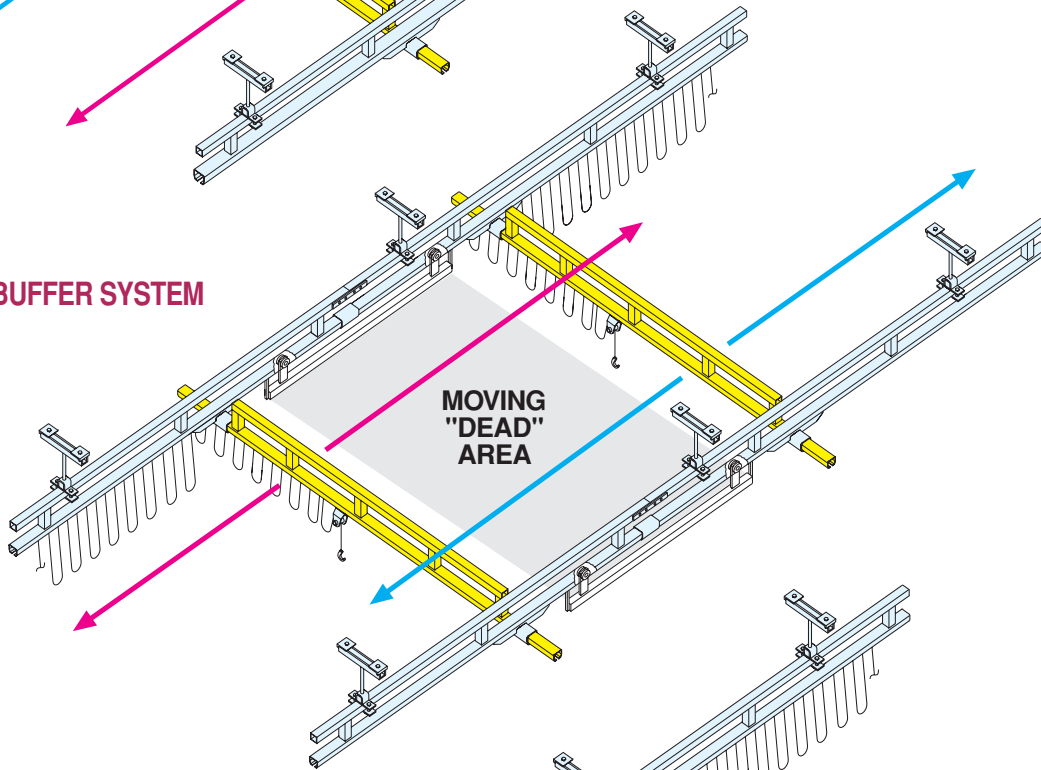

INTERMEDIATE STOPS SYSTEM

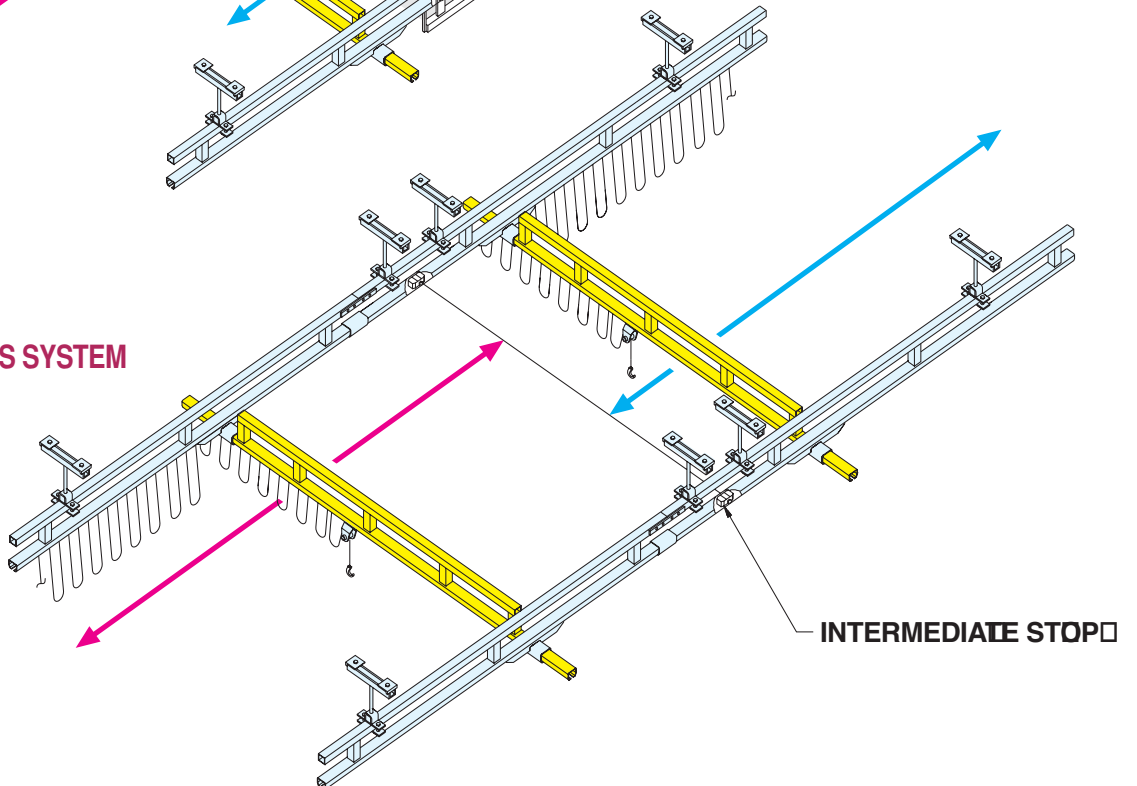

FOR MORE INFORMATION

Your authorized Gorbel® dealer can give you more information on what makes Gorbel's Ergonomic Work Station Cranes and other material handling products "A Class Above."

BRIDGE CRANES



FREE STANDING



CEILING MOUNTED

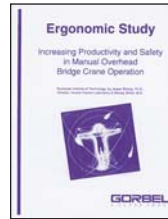

ERGONOMIC STUDY

ERGONOMIC LIFTING



G-FORCE®



EASY ARM™

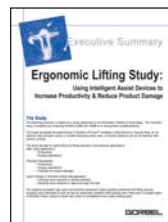

ERGONOMIC STUDY

JIB CRANES



JIB CRANES



GANTRY CRANES



WORK STATION JIBS



ARTICULATING JIBS

SPECIALTY PRODUCTS



SEISMIC ZONE IV



TELESCOPING



TRACTOR DRIVES



INTERLOCK/TRANSFER

GORBEL®
A CLASS ABOVE

www.gorbels.com

GORBEL
600 Fishers Run
PO Box 593
Fishers, NY 14453 USA

T 800.821.0086
T 585.924.6262
F 585.924.6273
E info@gorbel.com

CRANES