

# Installation, Operation, & Maintenance Manual

**TTSA-FS**

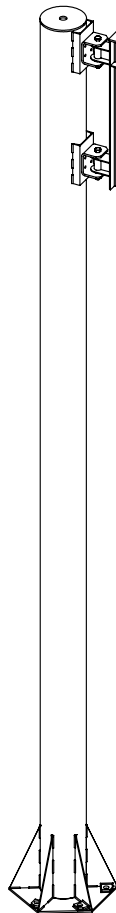

**TTSA**

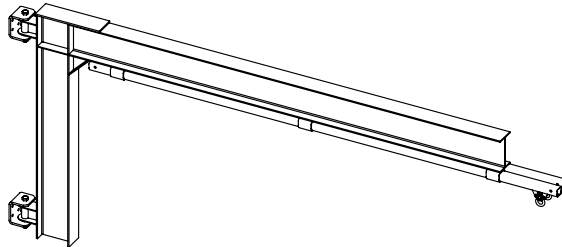

**IMPORTANT!  
DO NOT DESTROY**

## Tether Track® Swing Arm Systems

Gorbel® Customer Order No. / Serial No. \_\_\_\_\_

Gorbel® Dealer \_\_\_\_\_

Date \_\_\_\_\_  
Month Year

# TABLE OF CONTENTS

Introduction.....	1
Application.....	1
Warnings.....	2
Restrictions.....	3
Definition of Terms.....	3
Installation	
Step 1 - Pre-assembly.....	4-6
Step 2 - Wall/Column Swing Arm Installation.....	7
Step 3 - Free Standing Mast Installation.....	8-9
Step 4 - Free Standing Swing Arm Installation.....	10
Step 5 - Tether Track® Installation.....	10
Step 6 - Trolley Installation.....	11
Step 7 - Friction Brake Installation (Optional).....	11-13
Step 8 - Drive Installation (Optional).....	14
Step 9 - Electrification Installation (Optional).....	15
Step 9 - Rotation Stop Installation (Optional).....	16
Step 10 - Final Steps.....	16
Fall Arrest System Requirements.....	17-19
Labels.....	19
Authorized Person Instructions.....	20
General Operational Suggestions.....	21
Limited Warranty.....	22
Inspection and Maintenance Schedule.....	23-26

Questions? Concerns? Comments? Please call (800) 821-0086 (US and Canada) or (585) 924-6262 (outside US).

# INTRODUCTION

Thank you for choosing a Tether Track® Swing Arm by Gorbel to solve your fall protection needs. Tether Track® Swing Arms have been optimally designed to provide maximum protection for workers exposed to a fall hazard. When properly applied, configured and installed under the supervision of a qualified person, Tether Track® Swing Arms will allow the ultimate in user mobility by providing a mobile rigid anchorage for the attachment of a lanyard or self-retracting lanyard (SRL). Using a SRL combined with the engineered cantilever anchorage, provides the superior safety of a rigid system by minimizing fall distance while maximizing energy absorption of the fall arrest force. This reliable performance combined with an ANSI approved Managed Fall Protection Program gives the user the utmost safety assurance and encourages further safe work practices.

Tether Track® Swing Arms are designed using the most current ANSI guidelines and comply with all OSHA requirements for a fall arrest anchorage system. The use of ANSI's Maximum Average Arresting Force (MAAF) has been incorporated into the design standards for the Tether Track® Swing Arm. Tether Track® Swing Arm systems are designed to be statically proof tested up to 125% of the MAAF. If using lanyards or SRLs that are just rated for Maximum Arresting Force (MAF), this MAF rating shall not exceed the MAAF rating of the Tether Track® Swing Arm. When loaded through proof testing or during a fall event, the Tether Track® Swing Arm will not incur any visual permanent deformation and may be placed back into service after performing the inspection requirements detailed in this manual. Tether Track® Swing Arms have additionally been designed and tested to not sustain any visible deformation under the maximum OSHA allowed 1800 lb. dynamic arresting force. All engineered Tether Track® Swing Arm systems comply with OSHA's required safety factor of 2 and are designed in accordance with ANSI Z359.6.

The W-shape jib design provides the best economic flexibility to fit your specific fall zone requirements and provides the best design to allow for the greatest fall clearance height. This combined with a mobile trolley within our enclosed track all mounted on a freely pivoting hinge allows for the maximum ease of movement. These proven designs have been utilized in Gorbel's crane products for many years. Refer to the Introduction to Jib Cranes and Introduction to Work Station Cranes for more details and additional definition of terms.

## APPLICATION

Tether Track® Swing Arms are the best choice for providing coverage to a semi-circular fall zone. The rigid anchorage, maintaining the anchorage trolley overhead and the use of a "Class A" Self Retracting Lanyard provides the best solution to minimize fall distance when fall clearance height is restrictive. Note: specify Class A requirement at time of quote, standard design is for "Class B" SRLs. The pivoting arm can be swung out of the way of overhead cranes or equipment when the system is not in use. Thrust and pull forces are provided to determine the adequacy of the available support structure. These forces are calculated using proof loading requirements of  $1.25 * \text{MAAF}$  and dead weight. When an existing support structure is unavailable or inadequate, Free Standing Tether Track® Swing Arms can be provided. Foundation requirements are provided based on 3000 psi concrete strength and 2500 psi allowable soil bearing strength.

When using a Tether Track® Swing Arm for more than one worker, either the motorized or friction brake option is required. Both of these options, when properly adjusted, prevent excessive movement of the Swing Arm during a fall event while limiting high lateral impact stresses in the swing arm and supporting structure.

This product meets all applicable OSHA and ANSI standard for all protection.

***Dimensions contained in this installation manual are for reference only and may differ for your particular application. Please refer to the enclosed General Arrangement Drawing for actual dimensions.***

**Normal safety precautions:** These include, but are not limited to:

- Checking for obstructions in the fall clearance zone
- Coordinating fall hazard activities with assigned rescue personnel
- Making sure that end stops are in place
- Making sure that trolley freely moves
- For Motorized Swing Arms, verifying that lock out is in place
- When used by more than one worker at the same time, verifying friction brake or motorized clutch restricts Swing Arm rotation

For additional safety precautions, see page 21.

# WARNINGS

1. Do not throw away these instructions.
2. Only competent erection personnel familiar with standard fabrication practices should be employed to assemble these anchor systems. Gorbel is not responsible for the quality of workmanship employed in the installation of an anchor system according to these instructions. Contact Gorbel Inc. at 600 Fishers Run, P.O. Box 593, Fishers, New York 14453-0593, 800-821-0086, for additional information if necessary.
3. Consult a qualified structural engineer to determine if your support structure is adequate to support the loads generated by thrust and pull (wall/column mounted) or anchor bolt force, overturning moment, or axial load (free standing) of your anchor system. Gorbel Inc. assumes no responsibility for the adequacy or integrity of mounting surface.
4. Read and understand this manual before using equipment.
5. This manual should be read and understood in its entirety, and used as part of a training program as required by OSHA or any state and local regulatory agency.
6. This and any other included instructions shall be provided to the users of this equipment. The user shall understand the proper equipment use and limitations.
7. The Tether Track® Swing Arm Anchor System is only to be used as part of a complete fall protection system. The buyer or user is responsible for the safety and compatibility of the complete system.
8. Any component replacement, addition or change to the anchor system or the complete system requires evaluation by a qualified person.
9. Any fall event can result in injuries. The proper use of this equipment can substantially reduce an injury. For maximum safety, the worker shall be trained in the proper use of this equipment and all of the components of the fall arrest system.
10. Before each use, the equipment shall be inspected as outlined in the inspection section of this manual.
11. The rated capacity, the rated maximum average arresting force, and the rated maximum arresting force of the Tether Track® Swing Arm Anchor System shall not be exceeded. If the lanyard or SRL connected to the Tether Track® Swing Arm does not list a maximum average arresting force, the maximum average arresting force rating listed shall not exceed the rated maximum average arresting force of the Tether Track® Swing Arm Anchor System.
12. A managed fall protection program which includes a rescue plan is required for the safe use of this equipment. A worker suspended from this system can lose vital blood flow to the brain as blood pools in the legs. This is referred to as suspension trauma.
13. Reference the American Institute of Steel Construction (AISC) Manual of Steel Construction, Specification for Structural Joints using ASTM A325 or A490 Bolts (section 8.d.2) for the proper procedures to follow when using any torque tightening method.
14. Do not field modify the Tether Track® Swing Arm Anchor System in any way. Any modifications without the written consent of Gorbel Inc. will void warranty.
15. Gorbel has ensured the compatibility of Tether Track® **ONLY** with a Gorbel® approved anchor connector (fall arrest trolley). It is the responsibility of the dealer or end user to ensure proper design, function and compatibility of any trolley used with Tether Track® that has not been validated by Gorbel for a fall arrest application.
16. When using a Tether Track® Swing Arm without any rotation restriction device, do not apply a lateral force of greater than 10 lbs. A lateral force greater than 10 lbs may cause the Swing Arm to move until it reaches its rotation limit and pay out all of the line in the SRL. This may cause the user to be pulled off their working surface.
17. When using a Tether Track® Swing Arm with more than one worker, a rotation restriction device shall be engaged and an SRL with sufficient extra line (see page 16) shall be used. A leading edge fall arrest event may cause the Swing Arm to center over the leading edge.
18. Failure to follow these instructions can result in serious injury or death.

# RESTRICTIONS

1. The Tether Track® Swing Arm Anchor System shall be used as part of a complete active fall arrest system. Neither Gorbel nor its distributor takes responsibility for the system as a whole. The Tether Track® Swing Arm Anchor System is designed and tested by Gorbel in accordance with OSHA and ANSI Z359.1 & Z359.6 requirements using a minimum design factor of two. All components are designed in accordance with AISC guidelines.
2. The end user shall be responsible to make sure that the complete Fall Arrest System shall be designed, installed and used under the supervision of a qualified person in accordance with applicable OSHA regulations and ANSI Z359 Fall Protection Code voluntary consensus standard. State and local jurisdictions may have additional requirements.
3. It is the responsibility of the user to determine the sustainability of equipment and any attachments prior to each use and to have certification inspection on a periodic basis with recurrence not to exceed once per year by a qualified person.
4. Lanyards or self retracting lifelines (SRL) to be used with the Tether Track® Swing Arm Anchor System shall have a maximum arresting force (MAF) equal to or less than 900 lbs or they shall have a maximum average arresting force (MAAF) equal to or less than the MAAF rating of the Swing Arm.
5. Customer chosen lanyards or SRL shall minimize freefall distance.
6. It is the responsibility of the end user to verify that the mounting height of this Tether Track® Swing Arm Anchor System will provide adequate fall clearance when used with the customer chosen lanyard or SRL and harness.
7. Each trolley shall have no more than one person attached.
8. Trolleys are designed to freely move. To prevent a swing fall and the lengthening of the free fall distance, the user shall verify the trolley maintains the closest possible distance to the user whenever he or she changes position.
9. The Fall Clearance Zone shall be free of dangerous obstructions and electrical hazards as the Swing Arm may slowly rotate to its travel limit during a fall arrest event.
10. A friction clutch (motorized) or an engaged friction brake is required when more than one person is using the Swing Arm.
11. Only SRLs with sufficient reserve line shall be used when more than one person is using the Swing Arm. During a leading edge fall event, the Swing Arm may move laterally up to four feet. Extra line is required to prevent the second worker from being dislodged.
12. The Tether Track® Swing Arm Anchor System is intended only for indoor use.
13. The Tether Track® Swing Arm Anchor System shall be installed per the general arrangement drawing without deviation or modification.
14. This system is not designed to be used as a crane.

# DEFINITION OF TERMS

**AUTHORIZED PERSON** - ANSI defines an authorized person as a “person assigned by the employer to perform duties at a location where the person will be exposed to a fall hazard”.

**COMPLETE FALL ARREST SYSTEM** - A complete fall arrest system consists of three main components:

- A) Engineered Anchor System - Gorbel's Tether Track® has been engineered to provide the maximum safety possible. This system allows for the greatest worker mobility through Gorbel's ergonomic enclosed track design. It provides minimal fall distance by keeping the anchor point overhead and rigid.
- B) Body Support - Only a full body harness is allowed for fall arrest systems. Proper fitting and wearing of the harness is critical so that it can evenly dissipate the fall arrest forces to the strongest body parts.
- C) Connecting Means - This is the link between the anchor and body support. A self-retracting lifeline is recommended. This provides maximum mobility and minimum fall distance. An energy absorbing lanyard may also be used. These components have a maximum arresting force rating. Gorbel's standard Tether Track® design is based on a maximum arresting force of 900 lbs. or less.

**FALL CLEARANCE ZONE** - The space below the person where there is a potential to fall. This space must remain clear of obstructions to prevent injury from contact with any objects during a fall event.

**QUALIFIED PERSON** - ANSI defines a qualified person as “A person with a recognized degree or professional certificate and with extensive knowledge, training and experience in the fall protection and rescue field who is capable of designing, analyzing, evaluating and specifying fall protection and rescue systems...”

# INSTALLATION

## STEP 1 - PRE-ASSEMBLY

**TIP:** Packing list can be found in plastic pocket inside hardware box: General Arrangement Drawing can be found inserted in this installation manual.

- 1.1 Read entire manual **before** installing the Swing Arm.
- 1.2 Check packing list to ensure no parts have been lost prior to initiating assembly.
- 1.3 Tools and materials (by others) typically needed to assemble Swing Arm:
  - Torque wrench
  - Hand tools
  - Steel shims
  - Mounting hardware (by others, grade 5 bolts or better) for wall mounted swing arm
  - Anchor bolts (by others, grade 5 bolts or better) for free standing swing arm
  - Grout (Non-Shrink Precision Grout) for free standing swing arm
  - Base plate template for free standing swing arm
  - Leveling tools and plumb bob
  - Lifting device to lift heavy masts and swing arms
  - Heavy duty drill
- 1.4 Identify system type:

### WARNING

Consult a qualified structural engineer to determine that your support structure is adequate to support the loads generated by thrust and pull (wall mounted) or anchor bolt force, overturning moment, and axial load (free standing) of your Tether Track® Swing Arm Anchorage System.

#### Wall Mounted Swing Arm (diagram 1A)

Refer to **Chart 1A** to determine thrust and pull, bracket centers, and bolt pattern and dimensions, then proceed to **Step 2**, page 7.

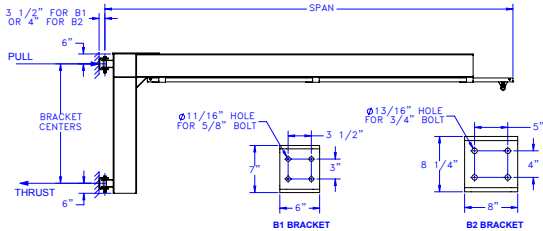

Diagram 1A. Wall Mounted Swing Arm.

#### Free Standing Swing Arm (diagram 1B)

Refer to **Charts 1B and 1C**, on pages 5 and 6, to determine anchor bolt load, footer width and depth and mast size, then proceed to **Step 3**, page 8.

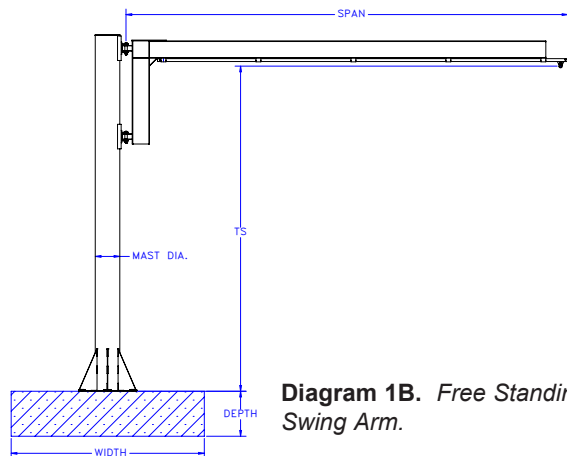

Diagram 1B. Free Standing Swing Arm.

	NUMBER OF WORKERS / TRACK	SPAN (FT)	MODEL NUMBER	BRACKET TYPE	**BRACKET CENTERS (FT)	APPROX WEIGHT (LBS)	***THRUST & PULL (LBS)
1	8	8	TTSA-WC-B1-1P-8	B1	3	215	3106
	10	10	TTSA-WC-B1-1P-10	B1	3	249	3934
	12	12	TTSA-WC-B1-1P-12	B1	3	365	4929
	14	14	TTSA-WC-B1-1P-14	B1	3	410	5839
	16	16	TTSA-WC-B1-1P-16	B1	4	472	5085
	18	18	TTSA-WC-B1-1P-18	B1	4	604	5980
	20	20	TTSA-WC-B1-1P-20	B1	5	681	5409
	22	22	TTSA-WC-B1-1P-22	B1	5	840	6255
	24	24	TTSA-WC-B1-1P-24	B1	6	926	4795
	26	26	TTSA-WC-B1-1P-26	B1	6	1118	6630
	28	28	TTSA-WC-B1-1P-28	B1	6	1672	8310
	30	30	TTSA-WC-B1-1P-30	B2	6	1809	9125
2	8	8	TTSA-WC-B1-2P-8	B1	3	312	6120
	10	10	TTSA-WC-B1-2P-10	B1	4	383	5804
	12	12	TTSA-WC-B1-2P-12	B1	4	441	7031
	14	14	TTSA-WC-B1-2P-14	B1	5	586	6715
	16	16	TTSA-WC-B1-2P-16	B1	6	755	6560
	18	18	TTSA-WC-B1-2P-18	B1	6	824	7460
	20	20	TTSA-WC-B2-2P-20	B2	6	1035	8525
	22	22	TTSA-WC-B2-2P-22	B2	6	1512	10140
	24	24	TTSA-WC-B2-2P-24	B2	6	1619	11240
	26	26	TTSA-WC-B2-2P-26	B2	6	1726	12370
	28	28	TTSA-WC-B2-2P-28	B2	6	1833	13530
	30	30	TTSA-WC-B2-2P-30	B2	6	2129	15118

Chart 1A. Wall Mounted Swing Arm \*Standard Configurations.

\* All Standard Configurations are based on a 900 lb. MAAF (for ANSI Z359.13 or Z359.14 rated lanyard or SRL) or 900 lb. MAF (for other rated lanyard or SRL)  
 \*\* Custom bracket centers are available (will affect loadings).  
 \*\*\* Thrust and pull force is based on proof load (1.25 \* 900 lb (MAAF or MAF) + dead load)

NUMBER OF WORKERS / TRACK	TROLLEY SADDLE (FT)	SPAN (FT)	MODEL NUMBER	MAST DIAMETER (IN)	**FOOTING DEPTH (IN)	**FOOTING WIDTH (IN)	APPROX. WEIGHT (LBS)	***ANCHOR BOLT LOAD (LBS)
1	14	8	TTSA-FS-WC-B1-1P-8-14	8.625	6	6.3	687	2146
		10	TTSA-FS-WC-B1-1P-10-14	12.75	48	4	905	2837
		12	TTSA-FS-WC-B1-1P-12-14	12.75	48	4.25	1028	3626
		14	TTSA-FS-WC-B1-1P-14-14	12.75	48	4.5	1072	4358
		16	TTSA-FS-WC-B1-1P-16-14	12.75	48	4.75	1135	5113
		18	TTSA-FS-WC-B1-1P-18-14	12.75	48	5	1272	6066
		20	TTSA-FS-WC-B1-1P-20-14	12.75	48	5	1349	6906
		22	TTSA-FS-WC-B1-1P-22-14	12.75	48	5.25	1514	8035
		24	TTSA-FS-WC-B1-1P-24-14	14	48	5.5	2018	7123
		26	TTSA-FS-WC-B1-1P-26-14	14	48	5.75	2217	8207
		28	TTSA-FS-WC-B1-1P-28-14	14	48	6.25	2782	10370
		30	TTSA-FS-WC-B1-1P-30-14	16	48	6.5	3129	4475
	16	8	TTSA-FS-WC-B1-1P-8-16	8.625	6	6.3	731	2134
		10	TTSA-FS-WC-B1-1P-10-16	12.75	48	4	972	2819
		12	TTSA-FS-WC-B1-1P-12-16	12.75	48	4.25	1095	3608
		14	TTSA-FS-WC-B1-1P-14-16	12.75	48	4.5	1139	4340
		16	TTSA-FS-WC-B1-1P-16-16	12.75	48	4.5	1201	5095
		18	TTSA-FS-WC-B1-1P-18-16	12.75	48	5	1339	6048
		20	TTSA-FS-WC-B1-1P-20-16	14	48	5	1873	5421
		22	TTSA-FS-WC-B1-1P-22-16	14	48	5.25	2041	6333
		24	TTSA-FS-WC-B1-1P-24-16	14	48	5.5	2128	7095
		26	TTSA-FS-WC-B1-1P-26-16	14	48	5.75	2326	8178
		28	TTSA-FS-WC-B1-1P-28-16	16	48	6.25	3117	4289
		30	TTSA-FS-WC-B1-1P-30-16	16	48	6.5	3254	4739
	18	8	TTSA-FS-WC-B1-1P-8-18	8.625	6	6.3	776	2122
		10	TTSA-FS-WC-B1-1P-10-18	12.75	48	4	1038	2801
		12	TTSA-FS-WC-B1-1P-12-18	12.75	48	4.25	1161	3590
		14	TTSA-FS-WC-B1-1P-14-18	12.75	48	4.5	1206	4322
		16	TTSA-FS-WC-B1-1P-16-18	12.75	48	4.5	1268	5078
		18	TTSA-FS-WC-B1-1P-18-18	14	48	4.75	1905	4713
		20	TTSA-FS-WC-B1-1P-20-18	14	48	5	1982	5393
		22	TTSA-FS-WC-B1-1P-22-18	14	48	5.25	2150	6304
		24	TTSA-FS-WC-B1-1P-24-18	14	48	5.5	2237	7066
		26	TTSA-FS-WC-B1-1P-26-18	16	48	5.75	2676	3368
		28	TTSA-FS-WC-B1-1P-28-18	16	48	6.25	3243	4272
		30	TTSA-FS-WC-B1-1P-30-18	18	48	6.25	3649	4001
	20	8	TTSA-FS-WC-B1-1P-8-20	12.75	6	6.2	1072	2119
		10	TTSA-FS-WC-B1-1P-10-20	12.75	48	4	1105	2783
		12	TTSA-FS-WC-B1-1P-12-20	12.75	48	4.25	1228	3573
		14	TTSA-FS-WC-B1-1P-14-20	12.75	48	4.5	1273	4304
		16	TTSA-FS-WC-B1-1P-16-20	14	48	4.5	1873	3915
		18	TTSA-FS-WC-B1-1P-18-20	14	48	4.75	2014	4684
		20	TTSA-FS-WC-B1-1P-20-20	14	48	5	2091	5364
		22	TTSA-FS-WC-B1-1P-22-20	14	48	5.25	2259	6276
		24	TTSA-FS-WC-B1-1P-24-20	16	48	5.5	2601	2898
		26	TTSA-FS-WC-B1-1P-26-20	16	48	5.75	2801	3352
		28	TTSA-FS-WC-B1-1P-28-20	18	48	6.25	3653	3595
		30	TTSA-FS-WC-B1-1P-30-20	18	48	6.25	3790	3983
	22	8	TTSA-FS-WC-B1-1P-8-22	12.75	6	6.2	1138	2101
		10	TTSA-FS-WC-B1-1P-10-22	12.75	48	4	1172	2765
		12	TTSA-FS-WC-B1-1P-12-22	12.75	48	4.25	1295	3555
		14	TTSA-FS-WC-B1-1P-14-22	12.75	48	4.5	1339	4286
		16	TTSA-FS-WC-B1-1P-16-22	14	48	4.5	1982	3886
		18	TTSA-FS-WC-B1-1P-18-22	14	48	4.75	2123	4655
		20	TTSA-FS-WC-B1-1P-20-22	14	48	5	2200	5335
		22	TTSA-FS-WC-B1-1P-22-22	14	48	5.25	2369	6247
		24	TTSA-FS-WC-B1-1P-24-22	16	48	5.5	2727	2882
		26	TTSA-FS-WC-B1-1P-26-22	16	48	5.75	2926	3335
		28	TTSA-FS-WC-B1-1P-28-22	18	48	6.25	3794	3577
		30	TTSA-FS-WC-B1-1P-30-22	20	48	6.25	4904	3336

**Chart 1B. Single Person, Single Track Free Standing Swing Arm \*Standard Configurations.**

\* All Standard Configurations are based on a 900 lb. MAAF (for ANSI Z359.13 or Z359.14 rated lanyard or SRL) or 900 lb. MAF (for other rated lanyards or SRLs)

\*\* Footing size is based on a 1.5 overturning safety factory of proof loading

\*\*\* Anchor bolt load is based on proof load (1.25 \* 900 lb (MAAF or MAF) + dead load)

NUMBER OF WORKERS / TRACK	TROLLEY SADDLE (FT)	SPAN (FT)	MODEL NUMBER	MAST DIAMETER (IN)	**FOOTING DEPTH (IN)	**FOOTING WIDTH (IN)	APPROX. WEIGHT (LBS)	***ANCHOR BOLT LOAD (LBS)
2	14	8	TTSA-FS-WC-B1-2P-8-14	12.75	48	4.5	974	4481
		10	TTSA-FS-WC-B1-2P-10-14	12.75	48	4.75	1045	5788
		12	TTSA-FS-WC-B1-2P-12-14	12.75	48	5	1103	7113
		14	TTSA-FS-WC-B1-2P-14-14	12.75	48	5.5	1254	8579
		16	TTSA-FS-WC-B1-2P-16-14	14	48	5.75	1847	8035
		18	TTSA-FS-WC-B1-2P-18-14	14	48	6	1916	9224
		20	TTSA-FS-WC-B2-2P-20-14	14	48	6.25	2134	10619
		22	TTSA-FS-WC-B2-2P-22-14	14	48	6.5	2622	12714
		24	TTSA-FS-WC-B2-2P-24-14	14	48	6.75	2729	14173
		26	TTSA-FS-WC-B2-2P-26-14	16	48	7	3046	6522
		28	TTSA-FS-WC-B2-2P-28-14	16	48	7.25	3153	7169
		30	TTSA-FS-WC-B2-2P-30-14	18	48	7.5	3697	6859
	16	8	TTSA-FS-WC-B1-2P-8-16	12.75	48	4.5	1041	4464
		10	TTSA-FS-WC-B1-2P-10-16	12.75	48	4.75	1112	5770
		12	TTSA-FS-WC-B1-2P-12-16	12.75	48	5	1170	7096
		14	TTSA-FS-WC-B1-2P-14-16	12.75	48	5.5	1321	8561
		16	TTSA-FS-WC-B1-2P-16-16	14	48	5.75	1956	8007
		18	TTSA-FS-WC-B1-2P-18-16	14	48	6	2025	9195
		20	TTSA-FS-WC-B2-2P-20-16	14	48	6.25	2243	10590
		22	TTSA-FS-WC-B2-2P-22-16	14	48	6.5	2731	12686
		24	TTSA-FS-WC-B2-2P-24-16	16	48	6.75	3064	5877
		26	TTSA-FS-WC-B2-2P-26-16	16	48	7	3171	6506
		28	TTSA-FS-WC-B2-2P-28-16	18	48	7.25	3531	6089
		30	TTSA-FS-WC-B2-2P-30-16	18	48	7.5	3838	6841
	18	8	TTSA-FS-WC-B1-2P-8-18	12.75	48	4.5	1108	4446
		10	TTSA-FS-WC-B1-2P-10-18	12.75	48	4.75	1179	5752
		12	TTSA-FS-WC-B1-2P-12-18	14	48	5	1733	5537
		14	TTSA-FS-WC-B1-2P-14-18	14	48	5.5	1887	6721
		16	TTSA-FS-WC-B1-2P-16-18	14	48	5.75	2065	7978
		18	TTSA-FS-WC-B1-2P-18-18	14	48	6	2134	9167
		20	TTSA-FS-WC-B2-2P-20-18	14	48	6.25	2352	10562
		22	TTSA-FS-WC-B2-2P-22-18	16	48	6.5	3083	5249
		24	TTSA-FS-WC-B2-2P-24-18	16	48	6.75	3189	5861
		26	TTSA-FS-WC-B2-2P-26-18	18	48	7	3566	5514
		28	TTSA-FS-WC-B2-2P-28-18	18	48	7.25	3673	6071
		30	TTSA-FS-WC-B2-2P-30-18	20	48	7.5	4824	5860
20	8	TTSA-FS-WC-B1-2P-8-20	12.75	48	4.5	1175	4428	
	10	TTSA-FS-WC-B1-2P-10-20	12.75	48	4.75	1246	5734	
	12	TTSA-FS-WC-B1-2P-12-20	14	48	5	1842	5509	
	14	TTSA-FS-WC-B1-2P-14-20	14	48	5.5	1996	6693	
	16	TTSA-FS-WC-B1-2P-16-20	14	48	5.75	2174	7950	
	18	TTSA-FS-WC-B1-2P-18-20	14	48	6	2243	9138	
	20	TTSA-FS-WC-B2-2P-20-20	16	48	6.25	2718	4358	
	22	TTSA-FS-WC-B2-2P-22-20	16	48	6.5	3208	5233	
	24	TTSA-FS-WC-B2-2P-24-20	18	48	6.75	3600	4954	
	26	TTSA-FS-WC-B2-2P-26-20	18	48	7	3707	5496	
	28	TTSA-FS-WC-B2-2P-28-20	20	48	7.25	4720	5175	
	30	TTSA-FS-WC-B2-2P-30-20	20	48	7.5	5032	5833	
22	8	TTSA-FS-WC-B1-2P-8-22	12.75	48	4.25	1241	4410	
	10	TTSA-FS-WC-B1-2P-10-22	12.75	48	4.75	1312	5717	
	12	TTSA-FS-WC-B1-2P-12-22	14	48	5	1951	5480	
	14	TTSA-FS-WC-B1-2P-14-22	14	48	5.5	2106	6664	
	16	TTSA-FS-WC-B1-2P-16-22	14	48	5.75	2284	7921	
	18	TTSA-FS-WC-B1-2P-18-22	16	48	6	2624	3757	
	20	TTSA-FS-WC-B2-2P-20-22	16	48	6.25	2843	4341	
	22	TTSA-FS-WC-B2-2P-22-22	16	48	6.5	3333	5217	
	24	TTSA-FS-WC-B2-2P-24-22	18	48	6.75	3741	4936	
	26	TTSA-FS-WC-B2-2P-26-22	18	48	7	3848	5478	
	28	TTSA-FS-WC-B2-2P-28-22	20	48	7.25	4928	5148	
	30	TTSA-FS-WC-B2-2P-30-22	20	48	7.5	5240	5807	

**Chart 1C. Two Person, Dual Track Free Standing Swing Arm \*Standard Configurations.**

\* All Standard Configurations are based on a 900 lb. MAAF (for ANSI Z359.13 or Z359.14 rated lanyard or SRL) or 900 lb. MAF (for other rated lanyards or SRLs)

\*\* Footing size is based on a 1.5 overturning safety factor of proof loading

\*\*\* Anchor bolt load is based on proof load (1.25 \* 900 lb (MAAF or MAF) + dead load)



## STEP 2 - WALL/COLUMN MOUNTED SWING ARM INSTALLATION

**TIP:** Upper and lower formed channel (brackets) are identical unless a rotation stop is welded to the bracket. In this case, the rotation stop bracket is the upper bracket (refer to Step 10, page 16).

### STOP!

Do not proceed if your support structure does not meet the loading requirements determined in Step 1.4.

- 2.1 Determine position of **upper-formed** channel bracket on support structure. Drill bolt holes (see **chart 1A** and **diagram 1A**, page 4, for bolt diameter and bolt to support structure).
  - 2.2 Determine position of lower formed channel bracket by measuring distance between bracket centers; clamp bracket to support structure. Align brackets by dropping plumb bob (by others) through pivot holes and making sure string is centered in pivot holes (**diagram 2A**). Shim, if necessary, between mounting surface and formed channel brackets (shims by others).
  - 2.3 Drill bolt holes for **lower** bracket (see **chart 1A** and **diagram 1A**, page 4, for bolt diameter) and bolt to support structure. Do not torque bolts until Swing Arm has been checked for drift (Step 2.5).
  - 2.4 Attach Swing Arm assembly to formed channel using hardware provided (**diagram 2B**). Be sure that thrust washers are in position. Tighten nuts on pivot bolt until lockwashers are compressed, being sure boom freely rotates.
  - 2.5 Carefully swing arm through entire travel to ensure boom is clear of obstructions and does not drift.
- If Swing Arm drifts**, support structure may be inadequate and/or shims may be required between mounting surface and channel brackets (refer to **Step 2.2** for pivot mounting assembly alignment).
- 2.6 Torque mounting bolts (grade 5 or better, by others) to manufacturer's specifications.
  - 2.7 Proceed to Step 5 on page 10.

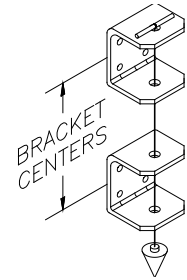

**Diagram 2A.** Plumbing formed channel brackets.

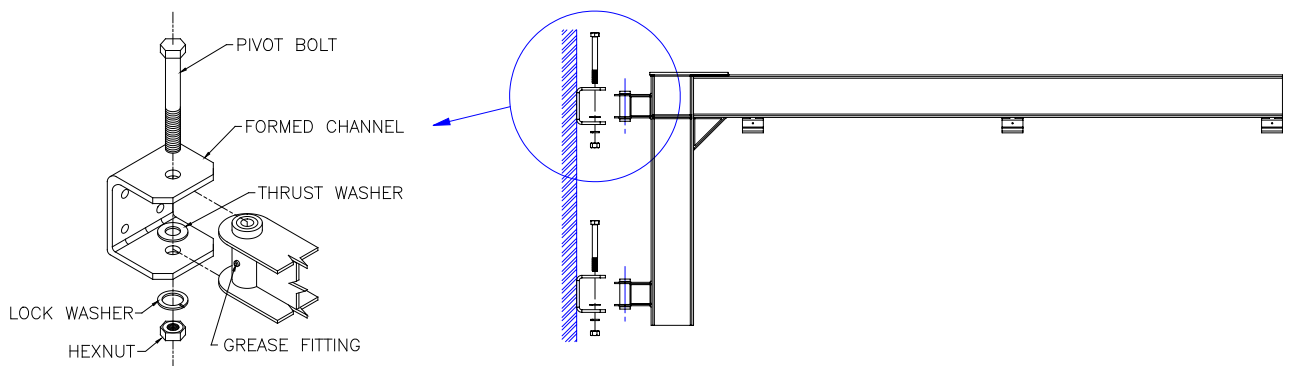

**Diagram 2B.** Attaching Swing Arm assembly to formed channel.

# STEP 3 - FREE STANDING MAST INSTALLATION



**STOP!**

Do not proceed if your foundation does not meet the size and loading requirements identified in **Step 1.4.**

## 3.1 INSTALLING ANCHOR BOLTS

3.1.1 Refer to **diagram 3A** or **3B** and **chart 3A** for bolt hole size and pattern for base plate thickness.

**WARNING**

Consult a qualified structural engineer if you deviate from the recommended dimensions provided in this manual or the General Arrangement Drawing. Gorbel, Inc. is not responsible for any deviation from these foundation recommendations.

### 3.1.2 Cast-in Anchor Bolts with Poured Foundations (6 or 12 bolt pattern):

**TIP:** Cast-in anchor bolts (J bolts) typically protrude 6" above foundation before mast is installed.

A) Anchor bolts (by others) must:

- be 1" diameter for 1-1/4" diameter base plate holes and 1-1/4" diameter for 1-1/2" diameter base plate holes.
- be embedded 3/4 of footer depth (L).
- have **minimum** of two threads above nut after installation.

B) Create steel-reinforced concrete foundation using recommendations shown in **diagram 3C**.

Refer to **chart 1B**, page 5, or **chart 1C**, page 6, for footer depth (L) and footer width (M) in **diagram 3C**.

**Note:** 7/16" thick, wafer board, bolt hole templates are available to facilitate anchor bolt alignment. Foundation requirements are based on soil pressure of 2500# per square foot. Concrete pressure recommended for foundation is 3000# per square inch of compressive force.

**Note:** Foundation/concrete must cure seven (7) days prior to mast installation. Foundation/concrete must cure 28 days prior to using Swing Arm.

C) Proceed to **Step 3.2**, page 9, for mast installation and plumbing.

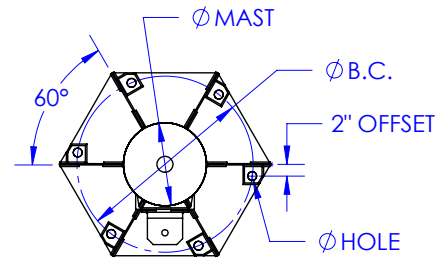

**Diagram 3A.** 6 bolt base bolt pattern.

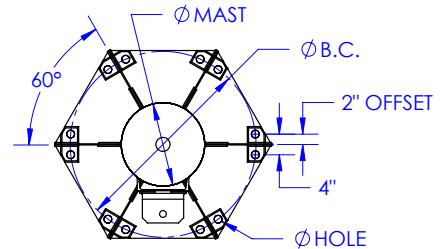

**Diagram 3B.** 12 bolt base bolt pattern.

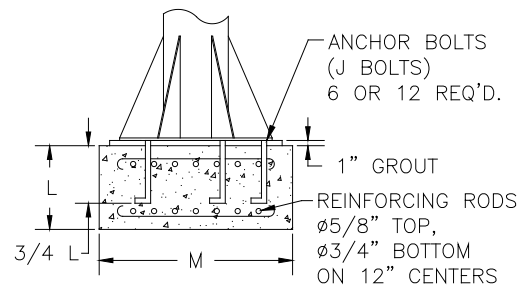

**Diagram 3C.** Poured foundation.

	Mast Diameter					
	8-5/8"	12-3/4"	14"	16"	18"	20"
6 Bolt or 12 Bolt Base	6	6	6	12	12	12
Diameter of Bolt Circle (B.C.)	24"	24"	30"	36"	42"	48"
Diameter of Bolt Hole	1-1/4"	1-1/2"	1-1/2"	1-1/2"	1-1/2"	1-1/2"
Hole Stiffener	No	Yes	Yes	Yes	Yes	Yes
Base Plate Thickness Including Stiffener	1/2"	1-1/4"	1-1/4"	1-1/4"	1-1/4"	1-1/4"

**Chart 3A.** Base plate dimensions.

## STEP 3 - FREE STANDING MAST INSTALLATION (CONTINUED)

### 3.1 INSTALLING ANCHOR BOLTS (CONTINUED)

#### 3.1.3 Post-Installed Anchor Bolts with Shallow Foundations (6 bolt pattern):

### WARNING

Shallow foundations are only appropriate for 8 foot span, one worker Swing Arms.

In addition to the requirements identified in **Step 1.4**, a minimum 6" thick reinforced concrete floor that is free of cracks, seams, expansion joints, and walls is required. Foundation requirements are based on a concrete compressive strength of 3000# per square inch, a soil bearing pressure of 2500# per square foot, and a modulus of subgrade reaction of 150# per square inch per inch.

A) Anchor bolts (by others) must:

- have an ICC-ES listing demonstrating suitability for the application.
- be installed in accordance with the manufacturer's instructions and requirements.

B) Base plate may be used as a template to drill holes in concrete floor. Follow anchor bolt manufacturer's recommendations for drill bit size, depth, and special inspection requirements.

**Note:** Base plates are designed for poured foundations. Hole size may exceed anchor bolt manufacturer's recommendations. Contact Gorbel® Customer Service if a custom base plate is required. Drill bushings or equivalent may also be used to reduce hole clearance. Bushings must not protrude above base plate. If base plate hole diameter is greater than bolt diameter plus 1/4", refer to AISC Design Guide 1 for minimum washer size and thickness recommendations.

C) Install anchor bolts and hardware according to manufacturer's installation instructions. **Diagram 3D** shows a typical installation.

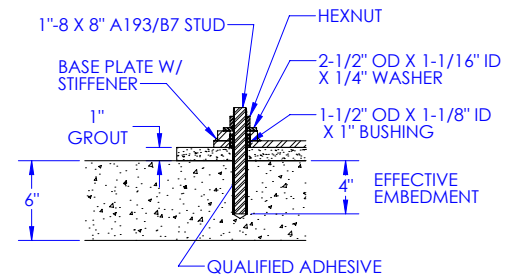

Diagram 3D. Anchor bolt installation.

**Note:** Before tightening hardware, follow instructions in **Step 3.2** for applying and curing grout.

### 3.2 Installing and Plumbing Mast

### WARNING

Mast must be plumb to prevent Swing Arm from drifting.

- Cover entire base plate area with one inch of non-shrink precision grout.
- Set mast into place and make sure that the base plate is completely seated in the grout.
- Thread a plumb line through Swing Arm mounting bracket holes and hole in tapered plug (by others) as shown in **diagram 3E**.
- Adjust mast as required until plumb line is centered in all the mounting hole brackets.
- Once mast is plumb **and grout has cured**, fully tighten anchor bolt hardware.
- Verify mast is still plumb.

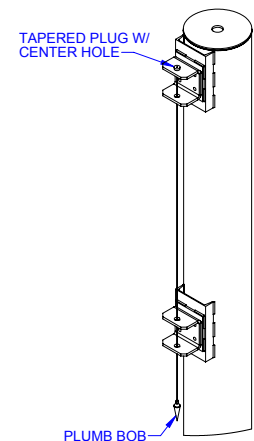

Diagram 3E. Plumbing the mast.

**DO NOT USE A LEVEL TO PLUMB MAST.**



## STEP 4 - FREE STANDING SWING ARM INSTALLATION

- 4.1 Attach Swing Arm to formed channel using hardware provided (*diagram 4A*). Be sure that thrust washers are in position. Tighten nuts on pivot bolt until lockwashers are compressed, being sure boom rotates freely.
- 4.2 Carefully swing arm through entire travel to ensure arm is clear of obstructions and does not drift.

If Swing Arm drifts, check to make sure mast is plumb and/or Swing Arm is squarely supported by both formed channel brackets. Shims may be used between thrust washer and channel bracket.

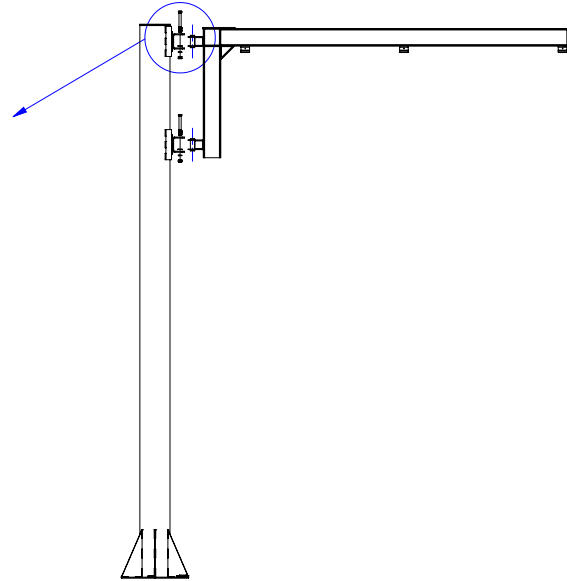
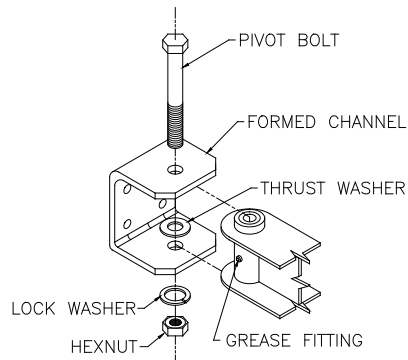

Diagram 4A. Attaching Swing Arm to mast.

## STEP 5 - TETHER TRACK® INSTALLATION

### WARNING

Do not overtighten clamping bolts on track supports: this will cause permanent damage to the Tether Track®.

- 5.1 Slide Tether Track® through all track supports on Swing Arm. Track must not extend further than 18" from the end of the arm.
- 5.2 Thread jam nuts down on clamping bolts (two at each track support). Thread clamping bolts with jam nuts into track supports and tighten until snug against track. Lock clamping bolt into place with jam nut (*diagram 5A*).

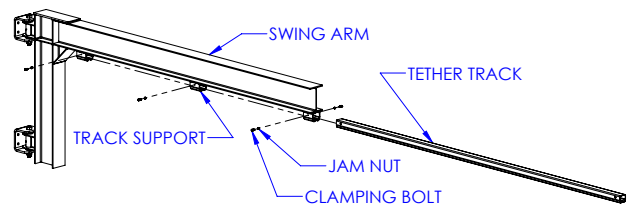

Diagram 5A. Attaching Tether Track® to Swing Arm.

- 5.3 Install end stop (molded bumper with thru bolt) in Tether Track® as shown (*diagram 5B*). Tighten nut on thru bolt until lockwasher is flat.
- 5.4 (**Dual Track Swing Arm only**) Repeat Steps 5.1 through 5.3 for second track.

### WARNING

Always ensure thru bolt is in place when using this product. Thru bolt prevents track from sliding out of track supports as well as capturing trolley in the track.

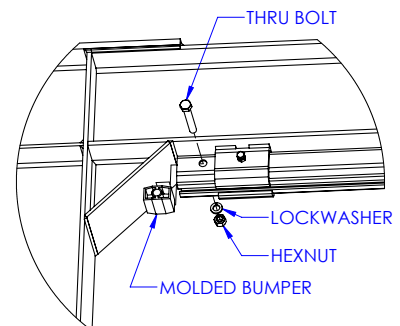

Diagram 5B. End stop installation.

## STEP 6 - TROLLEY INSTALLATION

- 6.1 Clean inside flanges of track with a clean, dry cloth (**do not use any kind of cleaning solution**) to remove grit or debris that may have collected during shipping, storage, or installation.
- 6.2 If using a self-retracting lifeline, attach self-retracting lifeline to trolley eye nut using ANSI approved hardware supplied with lifeline. Refer to the self-retracting lifeline manual.
- 6.3 Roll trolley into open end of track (**diagram 6A**).
- 6.4 Install second end stop per Step 5.3 (**diagram 5B**, page 10).
- 6.5 (**Dual Track Swing Arm only**) Repeat Steps 6.1 through 6.4 for second track.

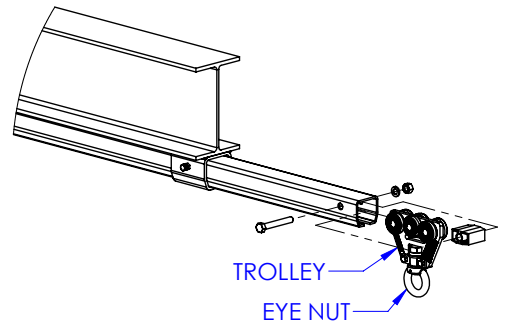

Diagram 6A. Trolley installation.

## STEP 7 - FRICTION BRAKE INSTALLATION (OPTIONAL)

### Brake Caliper Installation

- 7.1 If brake caliper lever is not assembled in orientation show (**diagram 7A**), remove cotter pin, adjuster nut, flat washer, lever mounting bolts and lock washers. Orient lever 60 degrees and reassemble.
- 7.2 Attach caliper to bracket (**diagram 7B**).
- 7.3 Attach spring seat to bracket. Route cable over pulley and install pulley to bracket (**diagram 7C**).

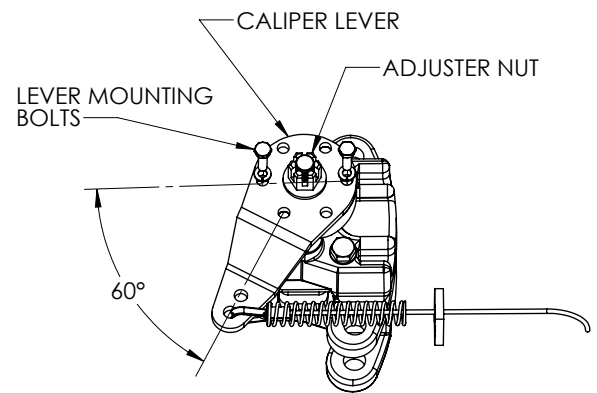

Diagram 7A. Brake caliper assembly.

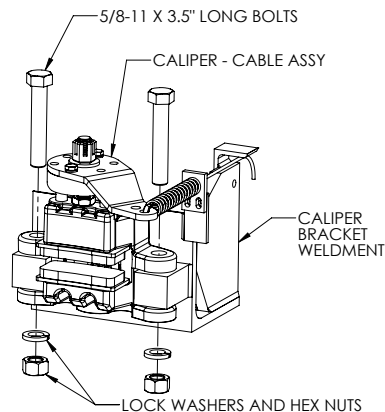

Diagram 7B. Attaching caliper to bracket.

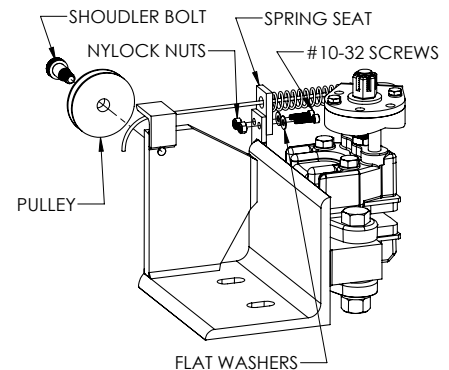

Diagram 7C. Assembling spring seat and pulley to bracket.

## STEP 7 - FRICTION BRAKE INSTALLATION (OPTIONAL) (CONTINUED)

### Brake Caliper Installation (continued)

- 7.4 Using pre-drilled holes in jib, attach bracket to jib (**diagram 7D**). Alternatively, bracket may be welded to jib following step 7.6. At this time, clamp in place as follows:
- distance from bracket to end of jib top plate =  $7\text{-}3/16"$  for 20" diameter rotor
  - distance from bracket to end of jib top plate =  $10\text{-}3/16"$  for 26" diameter rotor

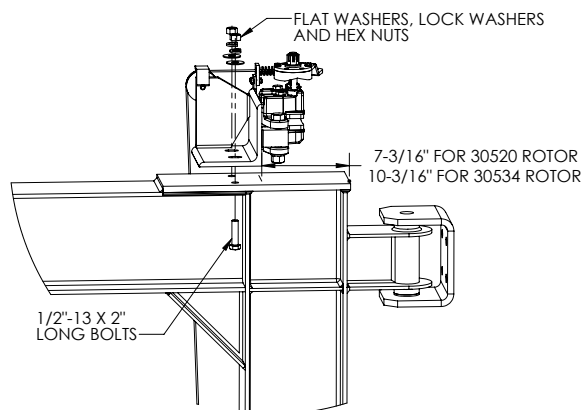

Diagram 7D. Attaching bracket to jib.

### Rotor Installation

- 7.5 Attach brake rotor to the wall mounting bracket using three  $3/8\text{-}16$ ,  $2\text{-}1/2"$  long hex bolts, nuts and lock washers (**diagram 7E**).
- 7.6 Slide rotor between brake pads as shown in **diagram 7F**. Loosen  $1/2"$  caliper bracket mounting bolts and position caliper so that rotor overlaps brake pads by  $1/16"$ . Tighten  $1/2"$  bolts to 50 ft.-lbs. of torque. Shims may be used on caliper and/or rotor bracket to properly align rotor and pads. Rotate boom to ensure no contact between caliper body and rotor.

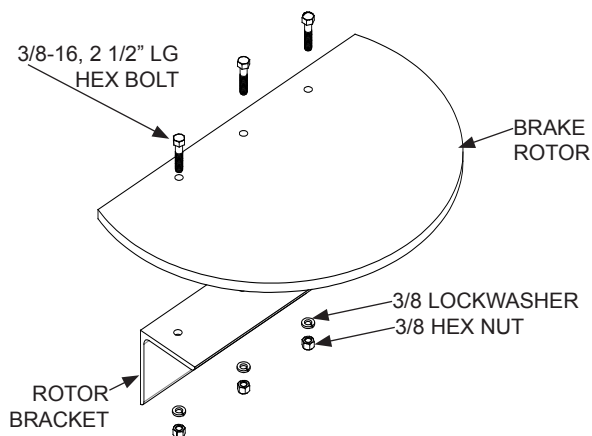

Diagram 7E. Attaching brake rotor to bracket.

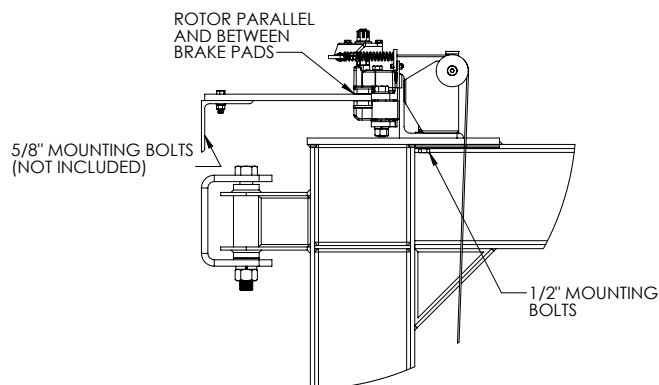
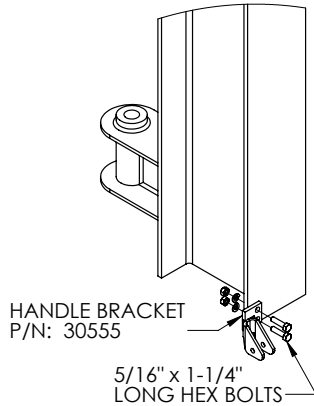

Diagram 7F. Installing rotor between brake pads.

# STEP 7 - FRICTION BRAKE INSTALLATION (OPTIONAL) (CONTINUED)

## Lever Bracket Installation

7.7 For beam depths 12" or less using rotor P/N 30520 and for beam depths 14" or less using rotor P/N 30534, locate lever bracket as shown in **diagram 7G**. For all other beam depths, locate lever bracket as shown in **diagram 7H**. Attach bracket to beam using 5/16" x 1-1/4" long hex bolts or weld brackets on both sides.



**Diagram 7G.** Lever bracket location.

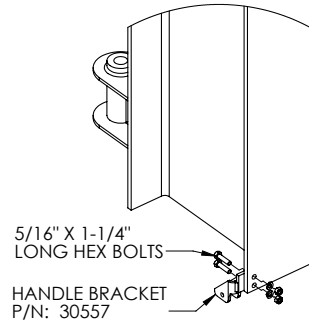
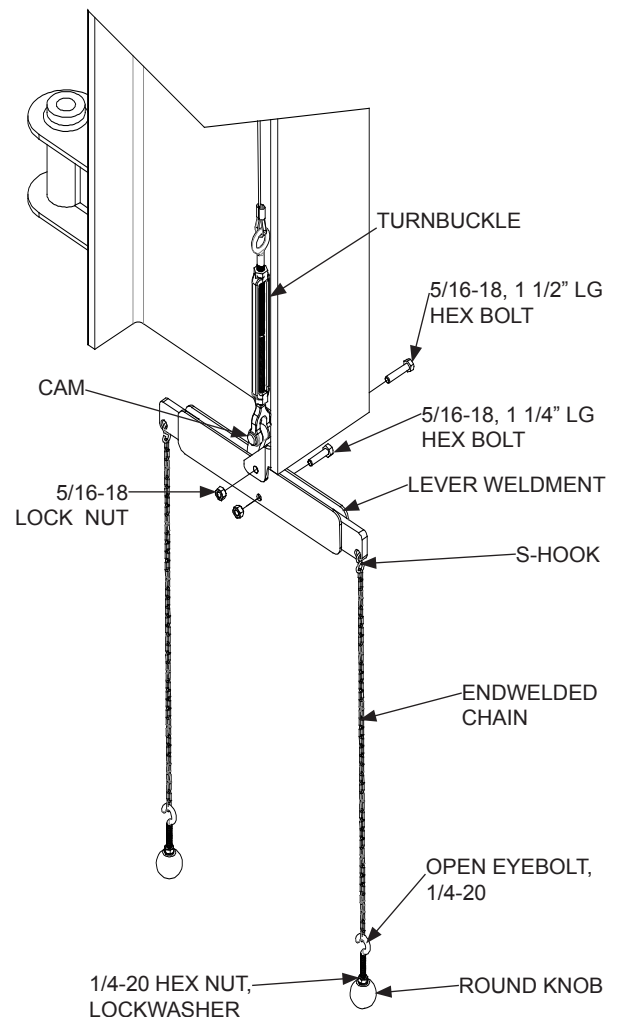

**Diagram 7H.** Lever bracket location.

## Lever Installation

7.8 Attach cam to turnbuckle and to the bottom hole of the lever weldment using 5/16-18, 1.25" long hex bolt and lock nut. Use 5/16-18, 1.5" long hex bolt and lock nut to attach lever weldment to the brake release bracket. Attach pull chains to the lever weldment using hardware show in **diagram 7J**.

7.9 Use turnbuckle to adjust cable tension and brake release lever action. When brake is properly adjusted it requires a minimum of 40 lbs. of horizontal force applied at the end of the boom to rotate.



**Diagram 7J.** Lever installation.

## STEP 8 - DRIVE INSTALLATION (WALL MOUNTED) (OPTIONAL)

Holes must be drilled in wall column to mount reducer assembly (refer to General Arrangement Drawing for hole pattern, bolt size, and pattern location). Spacer plates (when required) are shipped loose.

8.1 The clutch is pre-tightened by Gorbel. If any additional clutch adjustment is required, refer to the friction clutch instructions below. *If the clutch is not tightened properly, the lever arm may slip and the Swing Arm may not rotate properly.*

8.2 Layout reducer mounting location on support structure. Ensure that mounting surface of support structure is plumb along the plane comprising upper and lower pivot mounts and drive mount. Locate and drill holes.

8.3 Install swing arm according to instructions in Step 2 on page 7 or Step 4 on page 10. Hardware by others (grade 5 or better).

8.4 Lower drive assembly into place with lever arm engaged on pivot block and install mounting hardware (grade 5 or better, by others) but do not tighten. Verify that the drive is aligned with the axis of rotation of the swing arm and that there is approximately a 1" gap between the bottom of the lever arm and the top plate of the Swing Arm (**diagram 8B**). Torque drive mounting bolts (refer to **chart 8A** for proper torque rating).

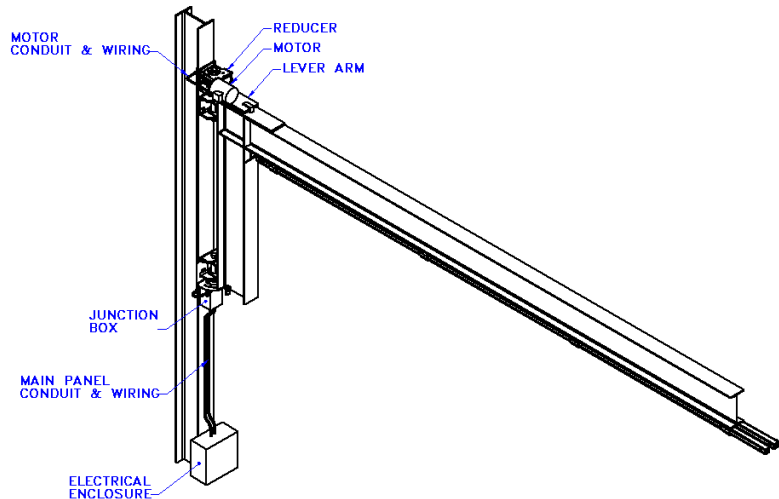

Diagram 8A. Drive installation.

Bolt Dia.	Torque
1/2"	50 ft.-lbs.
5/8"	95 ft.-lbs.
3/4"	175 ft.-lbs.
7/8"	300 ft.-lbs.
1"	450 ft.-lbs.

Chart 8A. Torque ratings.

### Friction Clutch Installation

During normal operation, adjustment to compensate for friction lining wear may be necessary. The frequency of these adjustments will be dependent on the frequency of overloads occurring.

8.5 **CLUTCH TORQUE ADJUSTMENT - SYSTEMS USED INDOORS**  
Loosen the locking screw on the adjusting nut. Using the hook wrench provided, turn the adjusting nut counterclockwise until the drive sprocket can turn freely in the clutch. The clutch can now be retightened to the proper torque setting. Turn the adjusting nut clockwise until it is hand tight. Using the hook wrench provided, tighten the adjusting nut an additional two full revolutions. After the adjustment is made, tighten the locking screw to ensure that the adjusting nut doesn't loosen. The proper torque setting is achieved when the drive sprocket will not slip under *normal* operating conditions (**diagram 8C**).

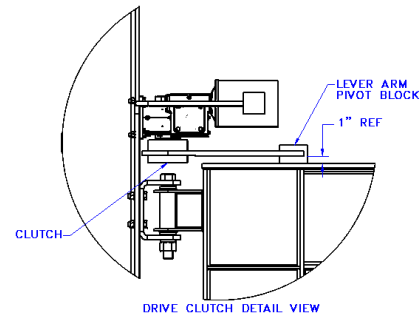

Diagram 8B. Drive clutch detail.

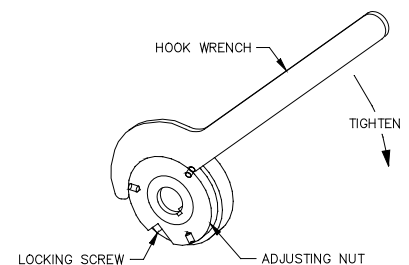

Diagram 8C. Indoor clutch torque adjustment.

**TIP:** The friction clutch is shipped **pretightened** by Gorbel. If the clutch begins to slip during initial use, allow the clutch to slip several times then retighten the clutch per the instructions below. The purpose for allowing the clutch to slip several times is to establish a uniform surface on the friction linings.



## STEP 9 - ELECTRIFICATION INSTALLATION (OPTIONAL)

9.1 When ordered with a motorized Fall Arrest system, an electrical control enclosure with pendant, junction box, wire and conduit will be included (shipped loose). Hardware to mount these components is supplied by others.

9.2 Enclosure must be mounted on a rigid structure away from all moving components and within reach of user to allow access to pendant and electrical disconnect. Typically it will be mounted on same wall/structure that the Swing Arm is located on.

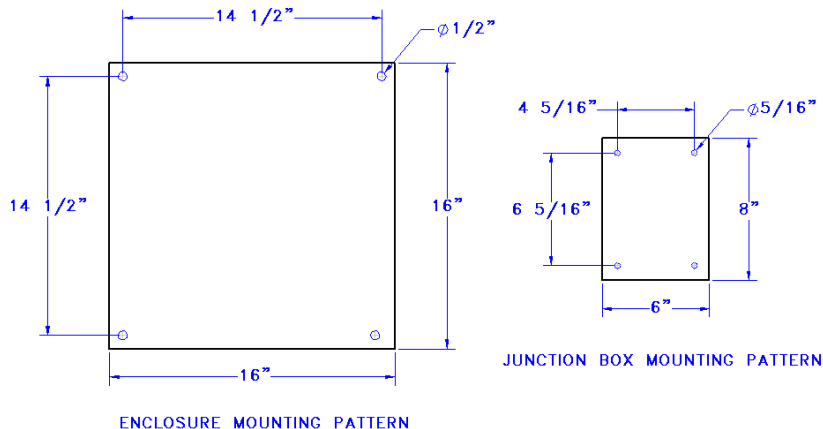

Diagram 9A. Mounting detail.

9.3 Level enclosure and mount to structure (hardware by others). For hole pattern, reference **diagram 9A**. Mount junction box (hardware by others) below vertical member of Swing Arm, **diagram 9A**.

9.4 If not already connected, wire limit switches into top of junction box (**diagram 9B**).

9.5 Connect power cable from motor to terminal in junction box. Ensure that conduit is located such that it will not be crushed by rotating Swing Arm.

9.6 Connect conduit and wire from junction box to main enclosure and make motor and limit switch connections.

9.7 Customer is responsible for providing incoming power to match required voltage of motor.

9.8 Reference **drawing E** and **E-1** for pendant and enclosure schematics when required.

9.9 Attach limit switch tab to bottom of vertical member of Swing Arm (**diagram 9C**) so that it does not interfere with the limit switch mount plate. Adjust limit switch lever arms to make contact with limit switch tab (**diagram 9D**). Position limit switches such that the Swing Arm is prevented from making contact with any object and the fall zone is away from dangerous machinery or conditions. **Ensure that limit switch mounting hardware is tightened.**

**Note:** Limit switch should be adjusted with power supply due to deceleration once the switch has been activated.

### WARNING

Only qualified personnel that are familiar with following local electrical codes and procedures are permitted to install these motorized systems. Gorbel is not responsible for the quality of workmanship employed in the installation of motorized assemblies.

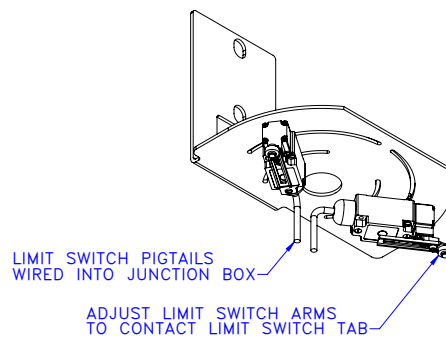

Diagram 9B. Limit switch assembly.

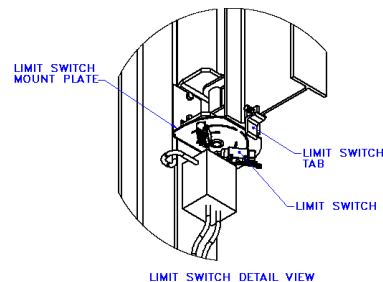

Diagram 9C. Limit switch detail.

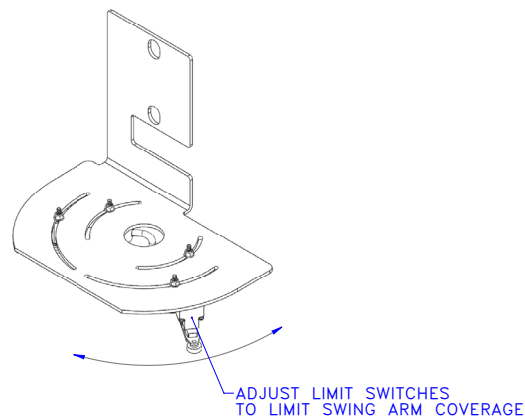
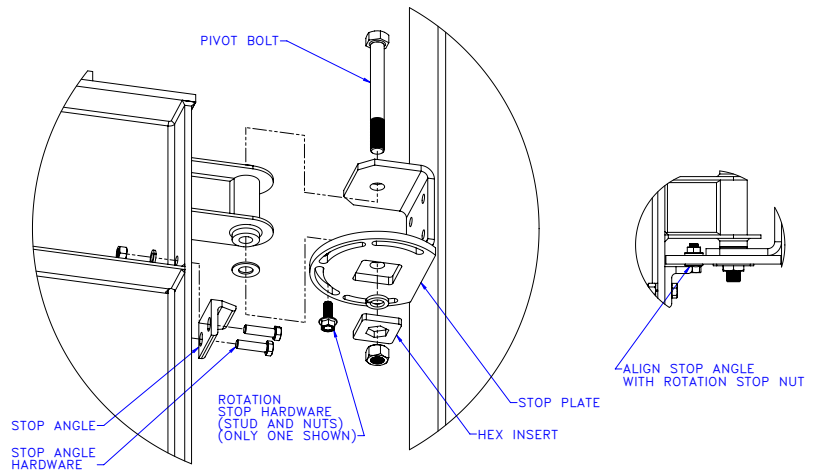

Diagram 9D. Limit switch adjustment.

## STEP 10 - ROTATION STOP INSTALLATION (OPTIONAL)

**10.1** When ordered with a rotation stop, one bracket will have a plate welded to it with slots to accept rotation stop bolts. This bracket must be installed as the upper bracket. Additionally, an angle with mounting hardware is included to be installed on the vertical member of the Swing Arm. Refer to **diagram 10A** for the following steps.

**10.2** Follow Swing Arm installation instructions in Step 2 on page 7 or Step 4 on page 10. When tightening the top pivot bolt, use the included insert as a socket to hold the nut while tightening the bolt (a deep socket or other method may be used at the installer's discretion). Once the bolt is tight, the insert may be removed but should be kept in the event the bolt ever needs to be removed.



**Diagram 10A.** Rotation stop installation.

**10.3** Install the rotation stop studs and nuts in the stop plate but do not fully tighten yet. Install the stop angle with included hardware and adjust vertically so the bottom of the angle is even with the top of the flange on the stop nut (**diagram 10A**). Torque hardware per **chart 8A**, page 14.

**10.4** Locate rotation stop hardware in the stop plate such that when the nut hits the stop angle, the Swing Arm is prevented from hitting any obstruction and that the fall zone is away from any dangerous machinery or conditions. Orient the nuts so the flat of the hex contacts the flat of the stop angle. Torque stop hardware per **chart 8A**, page 14.

## STEP 11 - FINAL STEPS

**TIP:** Do not throw away this manual: the maintenance schedule is on the back cover.

**11.1** Check to make sure all bolts are tight and lockwashers are compressed.

**11.2** Grease all fittings (use Lubriplate #630-AA or equivalent).

**11.3** If necessary, touch up system with paint provided.

**11.4** Install yellow rubber tracdoms on open ends of steel track.

**11.5** Verify capacity labels are legible from the ground or egress location.

**11.6** For more than a one worker system, verify that the required brake or drive is installed and verify that only a SRL with sufficient extra payout is being used. Additional line is required to allow the Swing Arm to move during a fall event without the SRL reaching its maximum length which may cause the second worker to lose his or her balance.

**11.7** Proof testing may be performed if required by state or local jurisdictions. The qualified person responsible for this fall arrest system may also request a proof load test. The Swing Arm Anchorage System has been designed to withstand a static proof load test not to exceed 125% of the rated MAAF with no visible permanent deformation. The trolley shall be slowly loaded to avoid additional dynamic loads. The proof load should be applied for a minimum of one minute. After this test is complete, the Swing Arm Anchorage System shall be inspected as if a fall event had occurred.

**11.8** Keep Packing List, Installation Manual, General Arrangement Drawing, and any other inserts filed together in a safe place.

# FALL ARREST SYSTEM REQUIREMENTS

**Vertical Fall Clearance:** The Tether Track® trolley will follow a worker along the length of the Swing Arm and remain overhead as long as the worker remains directly under the Swing Arm. However, as the worker moves horizontally away from the Swing Arm, the arm will likely remain until the worker gently moves it or a fall event occurs and the arm moves to the leading edge. If a SRL is being used, the extra payout of the lifeline must be accounted for in the fall clearance calculation. The worker must never exceed a 30 degree vertical offset angle with the trolley. The extra fall clearance distanced required is provided in the following calculation:

$$ODH = (TS - WS - DR) * (1/\cos\theta - 1) \text{ (diagram 1)}$$

Where: ODH = the offset distance height required to be included in the fall clearance calculation

TS = the trolley saddle height

WS = the working surface height

DR = the lowest height of worker's harness dorsal D-ring from working surface

$\theta$  = the vertical offset angle the worker is allowed (30 degrees maximum)

Here's a typical example:

- Worker Height (WH) = 6 ft.
- Minimum SRL Length including connectors (SL) = 2 ft.
- ANSI Z359.14 Class B SRL, Maximum Activation and Deceleration Distance (Arrest Distance, AD) = 4.5 ft.
- Safety Factor used in this example (SF) = 1.5 ft.
- Working Surface Height above nearest obstruction, ground or floor in this case (WS) = 10 ft.
- Worker may be required to kneel or crouch.
- Worker is allowed to work with a vertical offset angle of 20 degrees of his or her SRL line.

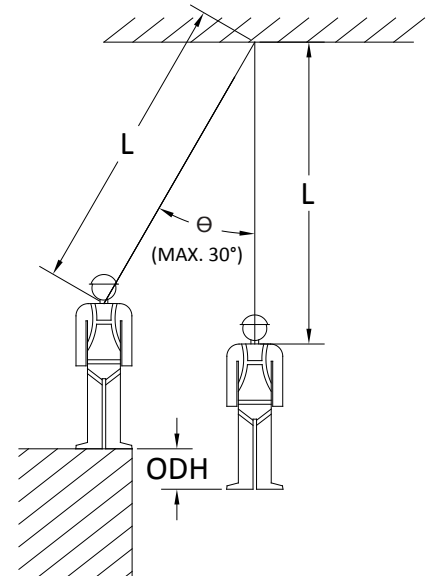

Diagram 1.

What is the lowest Trolley Saddle the Swing Arm may have? SRL's typically require that there be no slack in the line (see manufacturer's specific usage requirements). To achieve this, the trolley saddle must be the minimum SRL length above the workers dorsal ring.

$$\text{Minimum TS} = WS + WH - 1 \text{ ft} + SL = 10 + 6 - 1 + 2 = 17 \text{ ft.}$$

- Here 1 ft is taken as the distance from the dorsal ring to the worker's full height.

The trolley saddle may also be calculated to limit the worker's horizontal travel away from being directly under the Swing Arm. Additional information is SRL has a maximum length (SML) = 8 ft.

$$TS = WS + DR + SML * \cos\theta = 10 + 3 + 8 * \cos(20 \text{ degrees}) = 20.5 \text{ ft.}$$

- Here 3 ft is used as the minimum height of the dorsal ring above the working surface for a worker that is crouching or kneeling (DR = 3).

Is there sufficient clearance below the working surface to arrest a fall?

$$ODH = (TS - WS - DR) * (1/\cos\theta - 1) = (20.5 - 10 - 3) * (1/\cos(20 \text{ degrees}) - 1) = .5 \text{ ft.}$$

Required Clearance below working surface (RC)

$$RC = ODH + AD + SF + 1 + .33 + 2$$

- Here 1 ft is allowed for harness stretch, .33 ft or 4" is maximum allowed deflection for a rigid system, and 2 ft is allowed for additional leg clearance for a crouching person.

$$RC = .5 + 4.5 + 1.5 + 1 + .33 + 2 = 9.83 \text{ ft}$$

- 9.83 feet is less than 10 ft, therefore there is sufficient clearance for this application.

This example shows the importance of including the additional clearance requirements for allowing work horizontally away from the Tether Track® trolley. If the maximum allowed offset from vertical angle of 30 degrees was used, the required clearance would have exceeded the available clearance.

It is recommended to work directly below the anchorage trolley. However for some applications this may be difficult to achieve. The above calculation is identical to a swing fall calculation. However, in this case the Swing Arm will move to keep the lifeline vertical instead of the worker swinging. **Note:** even with the drive or friction brake option, the Swing Arm may move to the vertical lifeline position during a fall event.

## WARNING

A worker must not travel beyond the length of the Swing Arm.

# FALL ARREST SYSTEM REQUIREMENTS (CONT.)

**Horizontal Fall Clearance:** The Swing Arm, without the drive or friction brake, is designed to freely pivot so that a small gently applied force will allow the Swing Arm to be slowly moved into a directly overhead position.

## WARNING

Sudden movements or hard pulls on the lanyard or lifeline must be avoided. For Swing Arms without a friction brake or drive, a large force applied horizontally perpendicular to the Swing Arm will create inertia forces that may be difficult to resist and may cause a fall event.

The freely pivoting Swing Arm will reduce impact forces on the worker through the inertial acceleration of the Swing Arm for an offset from vertical fall. The Swing Arm may slowly rotate until an obstruction is encountered or the swing reaches its rotation limit (Swing Arm's full rotation is 210 degrees). If any dangerous obstructions are within the fall clearance zone, optional rotation stops are required to limit the fall clearance zone and keep it free of dangerous obstructions.

**Multiple User Systems:** If a single Swing Arm is to be used by more than one worker, the Swing Arm must have an optional friction brake or drive. In addition to this, only SRLs with extra available line shall be used. In the event of a fall, the Swing Arm must be restricted from movement so as to prevent a second worker from being pulled off his/her work surface. If the Swing Arm is equipped with the optional drive, it must be moved into the desired position and the drive electrical enclosure properly locked out prior to anyone working at height and using this system. If the Swing Arm is equipped with the optional friction brake, it must be moved into the desired position and the brake properly engaged prior to anyone working at height and using the system.

The brake and drive rely on friction to hold the Swing Arm in position. In the event of a fall, the Swing Arm may move to vertically align the activated lifeline and may rotate up to an additional 10 degrees. To reduce the potential of a second worker from falling, extra payout line is required in the SRL.

The worst case would occur when the falling worker is located near the pivot point and is at the maximum allowable vertical offset distance, and the second worker is located at the end of the boom and is at the maximum allowable vertical offset distance in the opposite direction. The following calculation is provided to determine the additional line required.

$$\text{Horizontal Offset Distance (HOD)} = (\text{TS} - \text{WS} - \text{WH} + 1) * \sin\theta$$

- Rotation of Swing Arm to align with leading edge at 4 ft from pivot (RSA) =  $\text{arc tan}(\text{HOD}/4)$
- Possible Horizontal Movement at end of Swing Arm (HM) =  $\text{SPAN} * \tan(\text{RSA} + 10 \text{ degrees})$
- Required SRL Length (RSL) =  $((\text{TS} - \text{WS} - \text{WH} + 1)^2 + (\text{HM} + \text{HOD})^2)^{.5}$

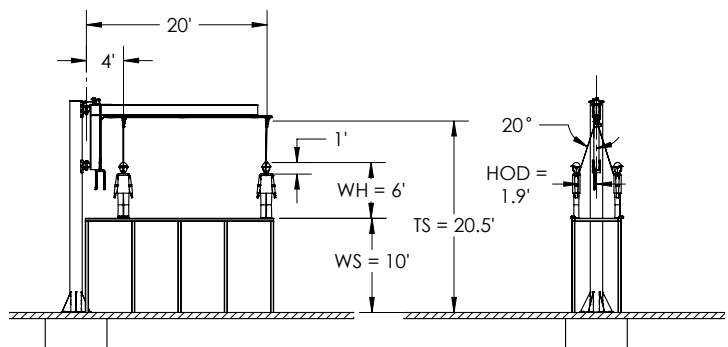

Here's an example using the values in the previous example and the Swing Arm span is 20 ft.

$$\begin{aligned} \text{HOD} &= (20.5 - 10 - 6 + 1) * \sin 20 = 1.9 \text{ ft.} \\ \text{RSA} &= \text{arc tan}(1.9/4) = 25.4 \text{ degrees} \\ \text{HM} &= 20 * \tan(25.4 + 10) = 14.2 \text{ ft.} \\ \text{RSL} &= ((20.5 - 10 - 6 + 1)^2 + (14.2 + 1.9)^2)^{.5} = 17 \text{ ft.} \end{aligned}$$

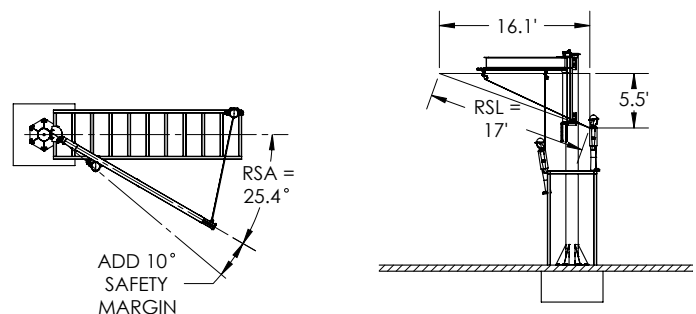

For this example, the maximum length of the SRL should be at least 17 feet. Further restrictions (other than a maximum offset angle of 20 degrees) may be enforced. For example, if the workers must remain 6 feet from each other, the maximum length of the SRL should be at least 10.5 ft. It is recommended to remain directly under the Swing Arm.

# FALL ARREST SYSTEM REQUIREMENTS (CONT.)

**Ratings:** Swing Arm labels contain the following four ratings:

- 1) Maximum number of workers. This will typically be 1 or 2 and represents the total number of workers that may simultaneously use the Swing Arm.  
**Note:** Each Tether Track® trolley may have only one worker attached.
- 2) Maximum worker weight. This is limited to 310 pounds and represents the maximum combined tool and body weight of each worker. Using fall arrest equipment has an inherent risk of injury. When used properly, a SRL and a Swing Arm will greatly minimize impact forces experienced by the worker. However, if there are any concerns that a user may not be able to tolerate the shock load during a fall arrest, they must not use this equipment. Concerns with exceeding this capacity are due to the higher internal forces that larger mass organs will generate and the increased risk of suspension trauma from the larger quantity of stale blood that the body must reprocess.
- 3) Maximum average arresting force. This is typically 900 pounds. This must be greater than or equal to the MAAF rating of an ANSI Z359.13 lanyard or a Z359.14 SRL that is being connected to the Swing Arm. For other lanyards and SRLs, the Swing Arm's maximum average arresting force rating must be greater than or equal to the maximum arresting force rating of the connected lanyard or SRL. **Note:** the static proof test load must be based on the maximum average arresting force rating of the Swing Arm multiplied by the maximum number of workers. Each trolley must have only one worker's MAAF applied to it.
- 4) Maximum arresting force of 1800 lbs. This is rated in conjunction with the maximum average arresting force rating used in ANSI Z359.13 and .14. **Note:** this rating can only be dynamically proof tested without causing permanent deformation to the Swing Arm.

## LABELS

### Swing Arm Labels



One worker Swing Arm label



Two worker Swing Arm label



Swing Arm one worker warning label



Swing Arm two worker warning label

### Trolley Labels



Trolley label

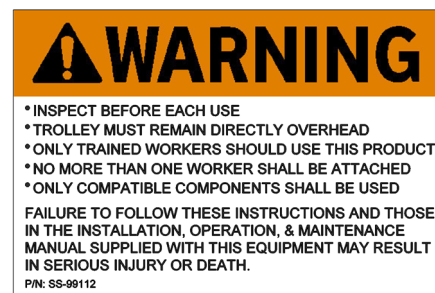

Trolley warning label

# AUTHORIZED PERSON INSTRUCTIONS

Performing duties where a fall hazard exists can be dangerous. Therefore, it is important for the Authorized Person to be instructed in the use of their Complete Fall Arrest System and to understand the severe consequences of careless use. It is not intended that these suggestions take precedence over existing plant safety rules and regulations or OSHA regulations. However, a thorough study of the following information should provide a better understanding of safe use and afford a greater margin of safety. It must be recognized that these are suggestions for the authorized person working in the presence of a fall hazard. It is the responsibility of the owner to make personnel aware of all federal, state and local rules and codes, and to make certain authorized persons are properly trained.

## Qualifications

Working while being exposed to a fall hazard, to be safe and efficient, requires skill: the exercise of extreme care and good judgment, alertness and concentration, and rigid adherence to proven safety rules and practices as outlined in applicable and current ANSI and OSHA safety standards. In general practice, no person should be authorized to work while being exposed to a fall hazard:

- Who cannot speak the appropriate language or read and understand the printed instructions.
- Who is not of legal age to work while being exposed to a fall hazard.
- Whose hearing or eyesight is impaired (unless suitably corrected with good depth perception).
- Who may be suffering from heart or other ailments which might interfere with their safe performance.
- Who may be pregnant or have any condition where the exposure to maximum arresting force of a fall event may be a health risk.
- Unless the person has carefully read and studied this operation manual.
- Unless the person has been properly instructed.
- Unless there is a rescue plan in place and at least one additional authorized person that has been instructed in the implementation of the rescue plan.
- Unless the person has demonstrated his or her instructions through practical use of the Complete Fall Arrest System.
- Unless the person is familiar with fall protection equipment and the safe use of this equipment.

## Handling the Swing Arm Motion for a One Worker System

Before using the Swing Arm of the Tether Track® Anchorage System, the Authorized Person should be sure that the Swing Arm is clear of any obstructions that would prevent it from freely rotating and that the fall zone, beneath where the work will be performed, is clear of any obstructions that would decrease the required fall clearance height. During use, the Swing Arm should be brought into position so that it is directly over the Authorized Person. The Authorized Person needs to become familiar with the force required to move the Swing Arm. Gentle application of force through the lanyard, locked SRL or a tagline will begin to rotate the Swing Arm. Allow the Swing Arm to continue to rotate until it is near the overhead position and then gently apply a braking force. The Swing Arm is designed to freely pivot and excessive force is not required. The force required to move the Swing Arm will depend on the size of the Swing Arm, the position of the trolley along the arm and the height the arm is above the user. While not exposed to a fall hazard, practicing moving and stopping the Swing Arm and varying the position of the trolley will aid the user in becoming familiar with the amount of force required. The Swing Arm has a large inertial mass. Sudden movements and/or excessive force may cause the Swing Arm to rapidly move and require braking forces that may cause loss of balance. The Authorized Person should only attempt to move the swing if he or she can easily control these inertial forces.

## Handling the Swing Arm Motion for a Two Worker System

Before using the Swing Arm of the Tether Track® Anchorage System, the Authorized Person needs to rotate the Swing Arm until it will be directly over the working surface. Once in position, the Swing Arm must be prevented from rotating. If the Swing Arm has the optional brake installed, the brake must be engaged prior to using the Swing Arm. If the Swing Arm has an electrical drive, the electrical enclosure must be locked out. The Swing Arm should be checked to verify it cannot be moved. The Authorized Person should verify that the fall zone, beneath where the work is to be performed, is clear of any obstructions that would decrease the required fall clearance height. In the event of a fall, the Swing Arm will slowly move until the fallen worker's lifeline is vertical. The second worker should brace himself or herself when this is noticed. The second worker's SRL must have additional line to payout so that the worker will not be tugged off balance.

## Handling the Trolley Motion

Before using the trolley of the Swing Arm Tether Track® Anchorage System, the Authorized Person should be sure that the trolley is clear of any obstructions that would prevent it from freely traveling along the Tether Track®. During use, the trolley should be brought into position so that it is directly over the Authorized Person. The trolley should follow the user's movement and remain overhead. Failure to keep the trolley overhead may cause a pendulum motion during a fall event that will increase fall distance and may expose the user to a side impact with any obstructions. A maximum off vertical angle of 30 degrees is allowed for the Swing Arm systems where the pendulum motion would be restricted by a vertical face. In this application, the top leading edge of the vertical face must not be sharp enough to cause damage to the lanyard or self retracting lifeline web or cable. Travel beyond the end of the Swing Arm is not allowed.

# GENERAL OPERATIONAL SUGGESTIONS

## Know Your Environment and Your Complete Fall Arrest System

Authorized persons should be familiar with the principal parts of the Fall Arrest System and have a thorough knowledge of the safe use, inspection, and limitations of this equipment. The authorized person should be required to know the procedure to rescue a person after a fall event and be trained to rapidly implement this procedure. The authorized person(s) should be aware of any condition that may change while they are exposed to a fall hazard that may jeopardize the integrity of the fall arrest system and the rescue plan. For example, obstructions moving into a fall clearance zone.

## Responsibility

Each authorized person(s) should be held directly responsible for the safe use of the Fall Arrest System. Whenever there is any doubt as to SAFETY, the authorized person should remove themselves from exposure to the fall hazard and refuse to re-expose themselves until safety has been assured. It is the responsibility of the employer to train the authorized person(s) in the safe use of the Fall Arrest System and to have managed Fall Protection in place.

Do not permit **ANYONE** to use this equipment unless they are authorized, there is at least one other authorized person within visual range, and there is a rescue plan in place.

## Inspection

Test the Tether Track® Anchorage System movement and any attachments and connections before each use. Whenever the authorized person(s) finds anything wrong or apparently wrong, the problem should be reported immediately to the proper supervisor and appropriate corrective action taken.

## Suggestions for the use of the Tether Track® Anchorage System

The authorized person should know and follow these suggestions for safe use of this protection equipment.

1. The trolley should move smoothly and gradually as the user moves. If a self retracting lifeline is being used and the retraction tension is not great enough to move the trolley, the SRL should be replaced.
2. The trolley should be located above the user and as close to the user as possible to minimize freefall distance. The user should verify that the trolley moves as close as possible to the user whenever he or she moves. In the event of a fall, this will help to prevent swinging. The user must not work outside of the designed fall zone.
3. For Swing Arm systems, lanyards and lifelines should be kept as close to vertical as possible. Offset falls will increase the freefall distance. This extra distance must be accounted for in the fall clearance calculations.
4. Be sure everyone in the immediate area is aware of your use of fall protection equipment and that the fall zone remains clear. Confirm that there is at least one person visually aware of your activities and that there is an authorized fall rescue person on-site.
5. Do not exceed the rated load capacity, number of workers, or maximum average arresting force of the Swing Arm Tether Track® Anchor System. Labels with this information are located on either side of the Swing Arm.
6. Make certain that before exposing yourself to a fall hazard, components are properly connected, connectors are properly oriented and latches are fully closed and locked.
7. Check to be sure that all trip hazards are removed and that the fall protection zone is clear of dangerous obstructions when moving to a new location on the Tether Track® Anchor System. Be aware of the boundaries of the fall protection zone. This is detailed on your General Arrangement Drawing supplied with the manual at the time of shipment.
8. At no time should the authorized person be working alone while exposed to a fall hazard. In the event of a fall, a worker left suspended will lose the ability to circulate blood by the contractions of muscles in their legs. This combined with being suspended vertically will eventually result in lack of blood flow to the brain can lead to death.
9. Do not use equipment with unused Y-lanyard webs, straps or taglines hanging loose. These should be properly stored to prevent tripping hazards and the possibility of snagging during a fall event that may cause an excessive arresting force.
10. This equipment should not be used for any purpose other than fall protection unless it has been specifically designed for multiple purposes.
11. When multiple trolleys are being used on the same Swing Arm, the Swing Arm must be locked to prevent excessive rotation of the Swing Arm that may dislodge a second worker during a fall event.
12. Whenever the authorized person leaves the Tether Track® Anchorage System the following procedure should be followed:
  - Verify that you are removed from the fall hazard or that you have another method of fall protection.
  - Remove your lifeline from the body harness D-ring or remove the lanyard from the trolley eye nut.
  - If using a self retracting lifeline, securely attach a tagline to the lifeline and allow it to slowly retract.
  - Remove lanyard and harness and clean any grease or dirt per manufacturer's instructions. Allow to drip dry and store in a cool, clean, dry environment out of direct sunlight.
  - Make a visual check before leaving anchor system.
  - Notify appropriate person that you are no longer using the fall arrest system.
13. After a fall event or if a safety concern is uncovered during inspection, an "out-of-service" warning sign or signal should be displayed at the access and egress point to this equipment until the system can be inspected and repaired or replaced.
14. ANY SAFETY FEATURES AND MECHANISMS BUILT-IN OR OTHERWISE PROVIDED WITH THE TETHER TRACK® ANCHOR SYSTEM BY GORBEL ARE REQUIRED FOR THE SAFE USE OF THIS EQUIPMENT. DO NOT, UNDER ANY CIRCUMSTANCES, REMOVE OR OTHERWISE IMPAIR OR DISABLE THE PROPER FUNCTIONING OF ANY SAFETY MECHANISMS OR FEATURES BUILT-IN OR OTHERWISE PROVIDED BY GORBEL FOR SAFE OPERATION OF THIS EQUIPMENT. ANY REMOVE, IMPAIRMENT OR DISABLING OF ANY SUCH SAFETY MECHANISMS OR FEATURES OR OTHER OPERATION OF THE TETHER TRACK® ANCHOR SYSTEM WITHOUT THE COMPLETE AND PROPER FUNCTIONING OF ANY SUCH SAFETY MECHANISMS OR FEATURES AUTOMATICALLY AND IMMEDIATELY VOIDS ANY AND ALL EXPRESS AND IMPLIED WARRANTIES OF ANY KIND OR NATURE.

## LIMITED WARRANTY

It is agreed that the equipment purchased hereunder is subject to the following LIMITED warranty and no other. Gorbel Incorporated ("Gorbel") warrants the manual push-pull Work Station Cranes, Jib Crane, and Gantry Crane products to be free from defects in material or workmanship for a period of ten years or 20,000 hours use from date of shipment. Gorbel warrants the Motorized Work Station Cranes and Jib Crane products to be free from defects in material or workmanship for a period of two years or 4,000 hours use from the date of shipment. Gorbel warrants the G-Force® and Easy Arm™ products to be free from defects in material or workmanship for a period of one year or 2,000 hours use from the date of shipment. This warranty does not cover Gantry Crane wheels. This warranty shall not cover failure or defective operation caused by operation in excess of recommended capacities, misuses, negligence or accident, and alteration or repair not authorized by Gorbel. No system shall be field modified after manufacture without the written authorization of Gorbel, Inc. Any field modification made to the system without the written authorization of Gorbel, Inc. shall void Gorbel's warranty obligation. OTHER THAN AS SET FORTH HEREIN, NO OTHER EXPRESS WARRANTIES, AND NO IMPLIED WARRANTIES, ORAL OR WRITTEN, INCLUDING BUT NOT LIMITED TO THE WARRANTIES OF MERCHANTABILITY OR FITNESS FOR PARTICULAR PURPOSE, ARE MADE BY GORBEL WITH RESPECT TO ITS PRODUCTS AND ALL SUCH WARRANTIES ARE HEREBY SPECIFICALLY DISCLAIMED. GORBEL SHALL NOT BE LIABLE UNDER ANY CIRCUMSTANCES FOR ANY INCIDENTAL, SPECIAL AND/OR CONSEQUENTIAL DAMAGES WHATSOEVER, WHETHER OR NOT FORESEEABLE, INCLUDING BUT NOT LIMITED TO DAMAGES FOR LOST PROFITS AND ALL SUCH INCIDENTAL, SPECIAL AND/OR CONSEQUENTIAL DAMAGES ARE HEREBY ALSO SPECIFICALLY DISCLAIMED. Gorbel's obligation and Purchaser's or end user's sole remedy under this warranty is limited to the replacement or repair of Gorbel's products at the factory, or at the discretion of Gorbel, at a location designated by Gorbel. Purchaser or end user shall be solely responsible for all freight and transportation costs incurred in connection with any warranty work provided by Gorbel hereunder. Gorbel will not be liable for any loss, injury or damage to persons or property, nor for damages of any kind resulting from failure or defective operation of any materials or equipment furnished hereunder. Components and accessories not manufactured by Gorbel are not included in this warranty. Purchaser's or end user's remedy for components and accessories not manufactured by Gorbel is limited to and determined by the terms and conditions of the warranty provided by the respective manufacturers of such components and accessories.

**A) DISCLAIMER OF IMPLIED WARRANTY OF MERCHANTABILITY**

Gorbel and Purchaser agree that any claim made by Purchaser which is inconsistent with Gorbel's obligations and the warranty remedies provided with Gorbel's products, and in particular, special, incidental and consequential damages, are expressly excluded.

**B) DISCLAIMER OF IMPLIED WARRANTY OF FITNESS FOR PARTICULAR PURPOSE**

Gorbel and Purchaser agree that the implied warranty of fitness for particular purpose is excluded from this transaction and shall not apply to the goods involved in this transaction.

**C) DISCLAIMER OF EXPRESS WARRANTY**

Gorbel's agents, or dealer's agents, or distributor's agents may have made oral statements about the machinery and equipment described in this transaction. Such statements do not constitute warranties, and Purchaser agrees not to rely on such statements. Purchaser also agrees that such statements are not part of this transaction.

**D) DISCLAIMER OF SPECIAL, INCIDENTAL AND CONSEQUENTIAL DAMAGES**

Gorbel and Purchaser agree that any claim made by Purchaser which is inconsistent with Gorbel's obligations and the warranty remedies provided with Gorbel's products, and in particular, special, incidental and consequential damages, are expressly excluded.

**E) DEALER OR DISTRIBUTOR NOT AN AGENT**

Gorbel and Purchaser agree that Purchaser has been put on notice that dealer or distributor is not Gorbel's agent in any respect for any reason. Gorbel and Purchaser also agree that Purchaser has been put on notice that dealer or distributor is not authorized to incur any obligations or to make any representations or warranties on Gorbel's behalf other than those specifically set forth in Gorbel's warranty provided in connection with its product.

**F) MERGER**

This warranty agreement constitutes a final and complete written expression of all the terms and conditions of this warranty and is a complete and exclusive statement of those terms.

**G) PAINTING**

Every crane (excluding components) receives a quality paint job before leaving the factory. Unfortunately, no paint will protect against the abuses received during the transportation process via common carrier. We have included at least one (1) twelve ounce spray can for touchup with each crane ordered (unless special paint was specified). If additional paint is required, contact a Gorbel® Customer Service Representative at 1-800-821-0086 or 1-585-924-6262.

**Title and Ownership:**

Title to the machinery and equipment described in the foregoing proposal shall remain with Gorbel and shall not pass to the Purchaser until the full amount herein agreed to be paid has been fully paid in cash.

**Claims and Damages:**

Unless expressly stated in writing, goods and equipment shall be at Purchaser's risk on and after Seller's delivery in good shipping order to the Carrier. Gorbel shall in no event be held responsible for materials furnished or work performed by any person other than it or its authorized representative or agent.

**Cancellations:**

If it becomes necessary for the purchaser to cancel this order wholly or in part, he shall at once so advise Gorbel in writing. Upon receipt of such written notice all work will stop immediately. If the order entails only stock items, a flat restocking charge of 15% of the purchase price will become due and payable by Purchaser to Gorbel. Items purchased specifically for the canceled order shall be charged for in accordance with the cancellation charges of our supplier plus 15% for handling in our factory. The cost of material and/or labor expended in general fabrication for the order shall be charged for on the basis of total costs to Gorbel up to the time of cancellation plus 15%.

**Returns:**

No equipment, materials or parts may be returned to Gorbel without express permission in writing to do so.

Extra Charge Delay: If Purchaser delays or interrupts progress of Seller's performance, or causes changes to be made, Purchaser agrees to reimburse Gorbel for expense, if any, incident to such delay.

**Changes and Alterations:**

Gorbel reserves the right to make changes in the details of construction of the equipment, as in its judgment, will be in the interest of the Purchaser; will make any changes in or additions to the equipment which may be agreed upon in writing by the Purchaser; and Gorbel is not obligated to make such changes in products previously sold any customer.

**Third Party Action:**

Should Gorbel have to resort to third party action to collect any amount due after thirty (30) days from date of invoice, the Purchaser agrees to pay collection costs, reasonable attorney's fees, court costs and legal interest.

**OSHA Responsibilities:**

Gorbel agrees to fully cooperate with Purchaser in the design, manufacture or procurement of safety features or devices that comply with OSHA regulations. In the event additional equipment or labor shall be furnished by Gorbel, it will be at prices and standard rates then in effect, or as may be mutually agreed upon at the time of the additional installation.

**Equal Employment Opportunity:**

Gorbel agrees to take affirmative action to ensure equal employment opportunity for all job applicants and employees without regard to race, color, age, religion, sex, national origin, handicap, veteran, or marital status. Gorbel agrees to maintain non-segregated work facilities and comply with rules and regulations of the Secretary of Labor or as otherwise provided by law or Executive Order.



# INSPECTION AND MAINTENANCE SCHEDULE

## GORBEL® TETHER TRACK® SWING ARM ANCHOR SYSTEMS: INSPECTION BEFORE EACH USE

OSHA and ANSI require an inspection of the entire fall protection system before each use. The Tether Track® Anchor System is a vital component of the complete fall protection system. Checking for the proper functioning of this system is essential. These pre-use checks are intended to be tactile and visual.

Verify the required maintenance procedures have been properly followed. Any extreme conditions that you are aware of that may have occurred since the last maintenance procedure should be reported to the proper supervisor and an evaluation made to determine if the maintenance schedule requires modification. Some examples of extreme conditions are: a fall arrest event, excessive vibration in the system or structure, swaying of the support structure, an impact to the system or support structure, or an unauthorized person working on the system.

The previous sections, Authorized Person Instructions and General Operational Suggestions, provide important pre-use and in-use instructions and inspection guidance. The following provides a suggested checklist divided into the six main components of the Tether Track® Swing Arm System. Components not listed require pre-use inspection as detailed by their manufacturers.

	YES	NO!
<b>AUTHORIZED PERSON</b>		
Are you authorized by your employer to perform work at height?		
Are you aware of a written procedure for the use of this equipment and does it include a rescue plan?		
Have you been trained in the use of this equipment?		
<b>SURROUNDING ENVIRONMENT</b>		
Is this system being used as approved by a qualified person?		
Is there adequate clearance to arrest a fall?		
Will you remain in the fall zone area allowed by this system?		
Are dangerous obstructions removed from the fall zone?		
Are nearby people aware of your pending work at height?		
Is there an authorized person within sight that has been trained in the rescue procedure?		
<b>SUPPORTING STRUCTURE</b>		
Is the integrity of the structure adequate?		
<b>CONNECTIONS TO TETHER TRACK® AND SWING ARM</b>		
Has scheduled maintenance been appropriately performed?		
<b>TETHER TRACK® AND SWING ARM</b>		
Is track horizontal?		
Are track and Swing Arm free of deformed, bent or damaged members?		
Are endstops in place?		
Is the Tether Track® Anchor System rated for the capacity and number of people using it?		
Does Swing Arm drift from desired position?		
If more than one worker is using the Swing Arm, has it been locked in the desired position?		
<b>TROLLEY</b>		
Is there only one lanyard or SRL attached to the trolley?		
Is lanyard or SRL compatibly attached to trolley eye nut?		
Does trolley freely roll and remain overhead?		

If the answer to any of these questions on the checklist is no, remove yourself from the fall hazard and report the issue to the proper supervisor.

# INSPECTION AND MAINTENANCE SCHEDULE (CONT.)

## GORBEL® TETHER TRACK® SWING ARM ANCHOR SYSTEMS: INSPECTION AFTER A FALL ARREST EVENT

### Supporting Structure (Wall Mounted)

- Inspect connections of formed channel brackets to the support. If there is any loose hardware, this may indicate that bolts have been stretched. Replace hardware if this is suspected or any damage is present.
- Inspect support structure mounting surface for damage or deformation. If there is visual damage or any reason to suspect damage, have qualified installers take the Swing Arm down. Repair the damage and re-install the Swing Arm.

### Supporting Structure (Free Standing)

- Inspect foundation and grout for any signs of damage or cracking. Repair as required.
- Inspect mast connections to foundations. Check torque requirements per anchor bolt manufacturer's instructions.
- Inspect mast for any visual cracking in welds and/or any permanent deformation around the channel brackets and base gussets. Repair or replace as required.

### Swing Arm

- Inspect formed channel brackets for deformation and cracks at formed bends. Repair or replace as required.
- Verify Swing Arm freely moves without drifting. Check pivot points for being out of plumb and shim as necessary.
- For drive option, verify normal operation. Check clutch slippage by applying a horizontal 40 pound force at the end of the Swing Arm. Tighten clutch as required so it does not slip at 40 pounds.
- For brake option, check rotation of Swing Arm with brake disengaged. If there is any binding, check rotor and caliper mounting and adjust for clearance as required. Engage brake and check turnbuckle adjustment by applying a horizontal 40 pound force at the end of the Swing Arm. Adjust as required to prevent slippage.

### Trolley

- Roll trolley in track listening for abnormal thumping noise. If heard, this indicates there may be debris sticking to wheel(s) or a flat spot on wheel(s) and wheel replacement is required.
- Remove endstop and carefully remove trolley from track section.
- Inspect trolley wheels for debris. clean off if any debris is found with clean dry cloth.
- Inspect black polyurethane washer between bolt head and metal washer for deformity. If bolt head is wedged into washer, press up on eyebolt while pulling down with hands until black washer and bolt head have separated.
- Further, visually inspect trolley wheels for flat spots and/or fractures. If any are found, specific wheel replacement is necessary.
- Place trolley back into track and secure with endstop and hardware.

# INSPECTION AND MAINTENANCE SCHEDULE (CONT.)

## GORBEL® TETHER TRACK® SWING ARM ANCHOR SYSTEMS: INSPECTION AFTER A FALL ARREST EVENT

### Tether Track®

- Loosen clamping bolts at track supports. This will relieve any stress and misalignment in the track that may be retained by the hardware. Re-tighten clamping bolts per instructions in Step 5 of this manual.
- At the location in the track where the fall arrest incident took place, measure the track opening and compare to the dimension and tolerance shown in **diagram A**. Replace track if measurement is not within the tolerance.
- Verify the Tether Track® has not undergone any other permanent deformation. This can be achieved by measuring the camber and bow (**diagram B**) of the track.
  - Using a string (kite), two clamps, and a measuring device (ruler, tape measure, etc.), measure from support to support (covering track area where arrest took place).
  - Clamp one end of string to the concave face of track, at the support. Travel to the other support pulling the string taut, not allowing it to sag, and clamp it in same location on track at the support.
  - Measure the distance from the string to the track face where the distance is greatest (usually at mid-span).
  - If this measurement is greater than  $.125'' \times \text{length of track in feet between supports} / 10'$  then replacement of track section is required.
  - Repeat this for both bow and camber.
  - If arrest took place on cantilevered portion of track, measurement will be from end of track to first support.
- Visually inspect endstops for fractures or deformation, replace if any are found.

### WARNING

All other components are to be inspected per their manufacturer's instructions.

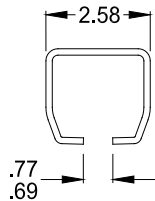

Diagram A. Track Opening Specification.

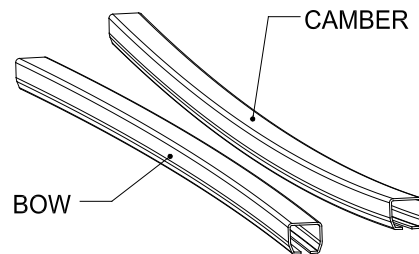

Diagram B. Camber and Bow.

# INSPECTION AND MAINTENANCE SCHEDULE

GORBEL® TETHER TRACK® SWING ARM INSPECTION AND MAINTENANCE SCHEDULE			
ITEM	COMPONENT	MAINTENANCE	FREQUENCY*
1	Mounting Bolts	Check that lockwashers are compressed and nuts tightened to manufacturers specifications.	Every 500 hours or 3 months
2	Pivot Assemblies	Check that lockwashers are compressed. Check for wear on thrust washers. Grease fittings (use Lubriplate #630-AA or equivalent).	Every 1000 hours or 6 months
3	End Stops	Check for full compression of lockwasher. If thru-bolt is exposed, replace endstops.	Every 2000 hours or yearly
4	Tether Trolley™ Connector	Check eyenut for wear. Check that clamp plate lockwashers are compressed. Check that black spring washer is not deformed. Check for smooth rolling action.	Every 2000 hours or yearly
5	Wheels	Check for cracks, pits and/or grooves: all of these increase pull forces. If any of these conditions exist, wheels should be replaced.	Every 2000 hours or yearly
6	Accessory Items	Conduct a general inspection of all accessory items.	Every 1000 hours or 6 months
7	Tether Track® Swing Arm	Conduct a visual inspection of wall cantilever Swing Arm weldment, Tether Track® and mast weldment.	Every 1000 hours or 6 months
8	Capacity and Warning Labels	Check that all labels are in place and legible. Replace labels if damaged or illegible.	Every 2000 hours or yearly
9	Connecting Equipment	Inspect all protective equipment connected to the Tether Track® Anchorage System following the operation and maintenance manuals provided for each piece of equipment.	As required by manufacturer

\*Federal, state and local codes may require inspection and maintenance checks more often. Please check the federal, state and local code manuals in your area. Gorbel recommends a certification inspection interval of no more than one year by a qualified person.

## WARNING

Any changes in rolling effort or unusual noises must be immediately identified and corrected. It is not necessary to lubricate the track or bearings. Lubricating may attract airborne particles and may increase the rolling resistance. **Do not use such substances as WD40®, silicone sprays, oil or grease.**

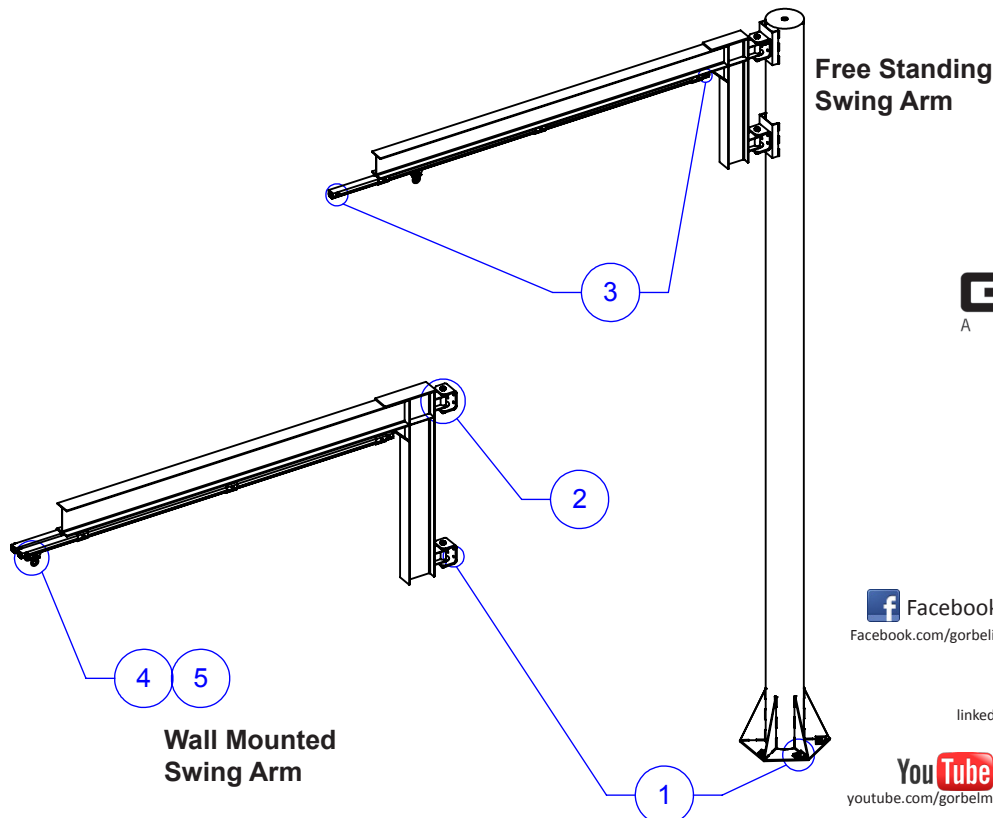

**GORBEL®**  
A CLASS ABOVE

600 Fishers Run, P.O. Box 593  
Fishers, NY 14453-0593  
Phone: (800) 821-0086  
Fax: (800) 828-1808  
E-Mail: info@gorbel.com  
http://www.gorbel.com

© 2012 Gorbel Inc.  
All Rights Reserved

Facebook  
facebook.com/gorbelinc

Twitter  
twitter.com/gorbelinc

LinkedIn  
linkedin.com/company/gorbel

YouTube  
youtube.com/gorbelmarketing

RSS  
gorbel.com/blog