

Moving Electrification *Forward*

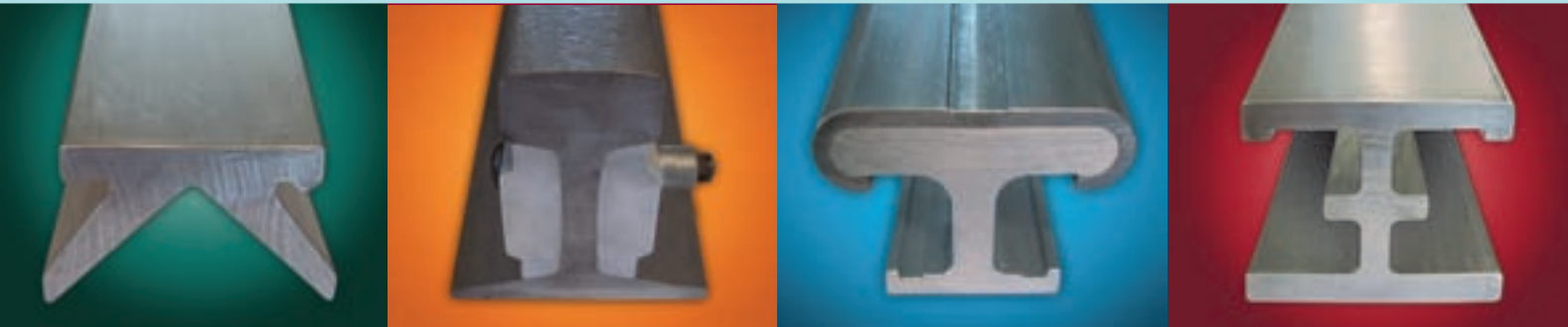

ENGINEERED CONDUCTOR SYSTEMS & COMPONENTS

For Electrification of Cranes, Hoists, Conveyors and Other Applications



Table of Contents

Section I - Insulators

Section II - Accessories

Section III - Collectors

Section IV - C-Bar

Section V - H-Bar

Section VI - V-Bar

Section VII - HV-Bar

Section VIII - HJ-Bar

Section IX - HC-Bar

Section X - Lec-Trol-Feed

Section XI - Transductor

Section XII - High Bay Reflector Bracket

Section XIII - Engineers Reference Material

Table of Contents



Insulators - Molded

Features

Molded fiberglass reinforced polyester insulators have found wide acceptance in industrial insulation systems because of their superior mechanical strength, toughness, excellent electrical characteristics even under high humidity conditions and good weatherability and corrosion resistance. These materials are thermosetting exhibiting high heat resistance, flame retardance, excellent mechanical and thermal shock resistance, track resistance, and will not shatter if dropped.

TransTech insulators are molded of premium grade polyester compounds which have been tested and recognized by Underwriters Laboratory.* The materials used in these insulators are designed for NEMA Class B insulation applications. The insulators are self-extinguishing per ASTM D635 with flame resistance of 153 seconds to ignition and 25 seconds burning per FTMS-S-406,2023.2.

All molded insulators are 100% inspected and hi-pot withstand tested up to 25 kV for 10 seconds.

Applications

Recommended applications include bus and switch support, contact rail and wire supports, panel and switchboard insulators, or any application requiring combined structural support and electrical insulation.

References

U.L. Material-Recognition Number E27875-E36714 Patented: U.S. No. 3,098,894

Insulators - Molded Polyester Fiberglass

Mechanical and Electrical Properties

Tensile Strength (Pounds).....	7,000
Cantilever Strength (Inch Pounds).....	12,000
Compression Strength (Pounds).....	65,000
Torsional Strength (Ft. Pounds).....	150+
Tracking Resistance (Arc, ASTM D495) (Sec.)	190
Flame Resistance (ASTM D635)	Self-Ext.
(ASTM D757) (Inch/Min.).....	0.264
(Federal Std. 406).....	12 ⁹ / ₅₄
Creep Distance (Inches) Plate to Plate	1/4 + "H"
Insert to insert.....	1 ³ / ₁₆ + "H"
Water Absorption (% in 24 hrs.) (ASTM D570)	0.28
Height Tolerance.....	±0.015
Maximum Service Temp., Continuous.....	300° F.
Intermittent.....	400° F.
Hi-Pot Withstand Test (100%) — KV.....	25

Corrugated Insulators

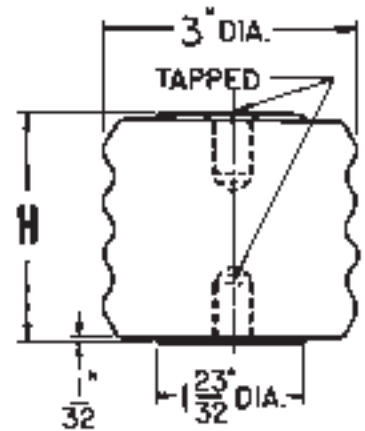

Catalog Information

Tap Size UNC - 2B	"H" = Height - Inches						
	2 ⁵ / ₈	2 ³ / ₄	2 ⁷ / ₈	3	3 ¹ / ₈	3 ¹ / ₄	3 ³ / ₈
1/2 - 13	88677	106600	106589	106590	106591	106592	106593
5/8 - 11	88678	106601	106594	106348	106595	106596	105960
3/4 - 10	89791	106602	106597	106349	106598	106599	105961

H = Height	2 ⁵ / ₈	2 ³ / ₄	2 ⁷ / ₈	3	3 ¹ / ₈	3 ¹ / ₄	3 ³ / ₈
Average Flashover Strength — Dry (K.V., S.T.)	40	40	45	45	50	50	55
Average Dew Flashover Strength (K.V., S.T.)	19	19.5	20	20.5	21	21.5	22
Impulse (K.V., 1.5 x 40 WAVE) WS*	80	84	88	92	96	100	104
Weight — Lbs.	1.75	1.8	1.85	1.9	1.95	2.0	2.05

Material:

Fiberglass reinforced polyester, electrical grade, corrosion resistant, red-poly standard grade #1. Color red.

*ASA C29.1 — 1951 American Standard Test Method Electrical Power Insulators

Insulators - Molded Red-Poly For Electrical Systems

Features

Featuring an all new self-cleaning configuration,* TransTech's new line of polyester fiberglass standoff insulators are offered in 69 standard size and shape varieties. All heights in either diameter also can be had with molded petticoat as illustrated. The petticoat will double the creepage distance and wet-flashover value. The flame retardance and track resistance ability of RED-POLY Insulators, plus the mechanical strength to withstand high shock and vibration, allow almost unrestricted application within the rated voltage.

The wide range of stock sizes and shapes enable the electrical system designer to use standard insulators for almost any space problem encountered. However, for special space problems, TransTech can supply insulators to exact heights required at a very small extra cost. Economical product of "specials" is a result of uniquely flexible and advanced manufacturing processes.

Material Grade

TransTech's Material Grades are engineered for use as structural insulating members in equipment designed to meet NEMA Class B Requirements.

Each item as catalogued is made of electrical grade corrosion and track resistant fiberglass reinforced polyester. This is a high strength material with superior weather-resistant characteristics.

Petticoats

The Petticoat provides a "Leakage Current Barrier" by effectively increasing the leakage distance, and is desirable for applications under conditions of excessive moisture, air contamination, etc.

Petticoat is available, as an integral part of any insulator size listed (See Ordering Directions).

Inserts

All inserts are corrosion resistant plated steel with NC-class 2 threads.

*Patent No. 3,098,894

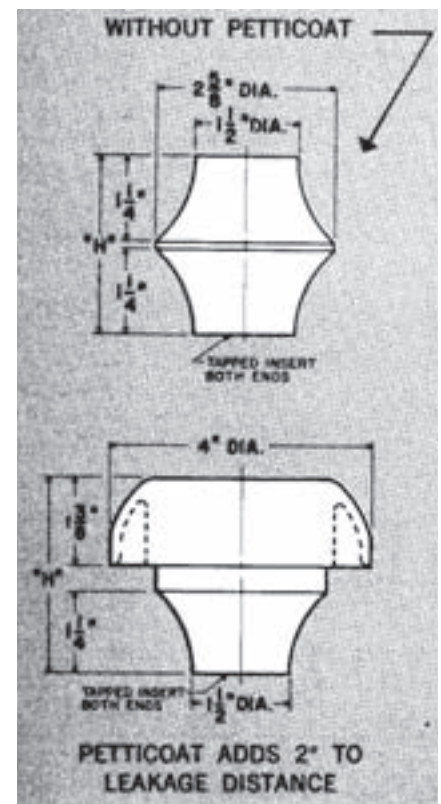
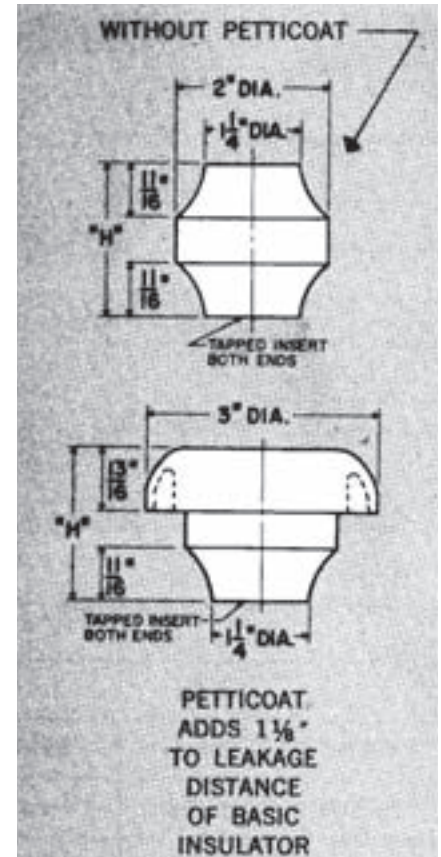
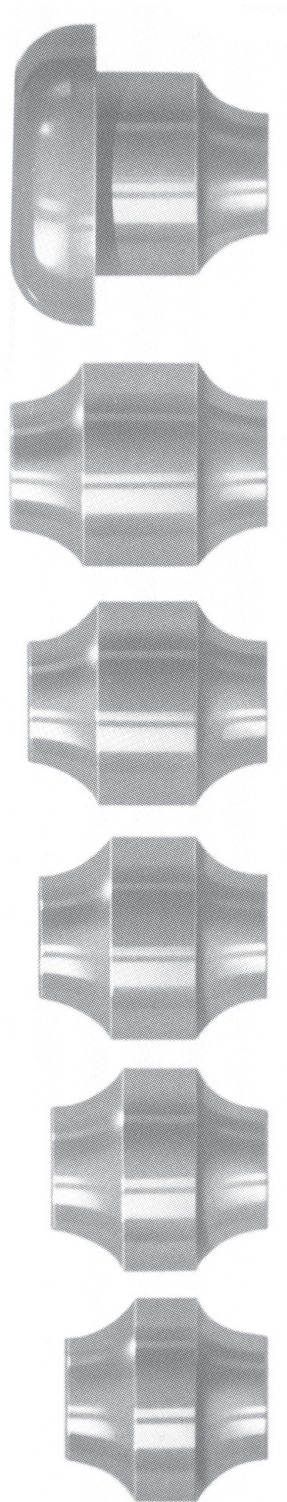

**Insulators - Molded
Red-Poly For Electrical Systems**

Catalog Number — 2" Dia.

Tap Size	"H" Dim								
	1 1/2	1 5/8	1 3/4	1 7/8	2	2 1/8	2 1/4	2 3/8	2 1/2
1/4 - 20	9455101	9455102	9455103	9455104	9455105	9455106	9455107		
5/16 - 18	9455108	9455109	9455110	9455111	9455112	9455113	9455114		
3/8 - 16	9455115	9455116	9455117	9455118	9455119	9455120	9455121	9455122	9455123
1/2 - 13			9455124	9455125	9455126	9455127	9455128	9455129	9455130
5/8 - 11			9455131	9455132	9455133	9455134	9455135	9455136	9455137

Ordering Directions

- To Order insulators with Petticoat, change 51 to 71 in Cat. No.

Average Mechanical and Electrical Properties

Ultimate Tensile Strength (Pounds)	Track Resistance, Inclined Plane D2303 (Min.).....	1,200
1 1/2" to 1 7/8" High.....	Arc Resistance (Arc, ASTM, D-495) (Sec).....	190
2" to 2 1/2" High.....	Flame Resistance (ASTM, D-635).....	Self. Ext.
Ultimate Cantilever Strength (Inch-Pounds)	Creep Distance (Inches - without Petticoat).....	1/4 + H
1 1/2" to 1 7/8" High.....	(Inches - with Petticoat).....	1 3/8 + H
2" to 2 1/2" High.....	Water Absorption (% in 24 Hours) (ASTM, D-570).....	0.28
Ultimate Compression Strength (Pounds).....	Height Tolerance (Inches).....	± .015
Ultimate Torsional Strength (Ft-Pounds).....		50

H = Height	1 1/2	1 5/8	1 3/4	1 7/8	2	2 1/8	2 1/4	2 3/8	2 1/2
Flashover Strength - Dry (K.V., S.T.)	35	35	35	35	38	38	38	38	38
*Dew Flashover Strength (K.V., S.T.) w/o Petticoat	12	12.5	13	13.5	14	14.5	15	15.5	16
*Dew Flashover Strength (K.V., S.T.) w/ Petticoat	19	19.5	20	20.5	21	21.5	22	22.5	23
*Impulse (K.V., 1.5 x 40 WAVE) WS	25	30	35	40	45	50	55	60	65
Weight (lbs.) plus .15 lb. for Petticoat	.22	.26	.30	.34	.38	.42	.46	.50	.54

*A.S.A. C29.1 — 1961 American Standard Test Method Electrical Power Insulators

Catalog Number — 2 5/8" Dia.

Tap Size	"H" Dim							
	2 5/8	2 3/4	2 7/8	3	3 1/8	3 1/4	3 3/8	3 1/2
3/8 - 16	9456101	9456102	9456103	9456104	9456105	9456106	9456107	9456108
1/2 - 13	9456109	9456110	9456111	9456112	9456113	9456114	9456115	9456116
5/8 - 11	9456117	9456118	9456119	9456120	9456121	9456122	9456123	9456124
3/4 - 10	9456125	9456126	9456127	9456128	9456129	9456130	9456131	9456132

Ordering Directions

- To Order insulators with Petticoat, change 61 to 81 in Cat. No.

Average Mechanical and Electrical Properties

Ultimate Tensile Strength (Pounds)	5,000	Flame Resistance (ASTM, D-635).....	Self. Ext.
Ultimate Cantilever Strength (Inch-Pounds)	4,500	Leakage Distance (Inches - without Petticoat)	3/8 + H
Ultimate Compression Strength (Pounds).....	28,000	(Inches - with Petticoat).....	2 3/8 + H
Ultimate Torsional Strength (Ft-Pounds).....	150	Water Absorption (% in 24 Hours) (ASTM, D-570).....	0.28
Track Resistance, Inclined Plane D2303 (Min.).....	1,200	Height Tolerance (Inches).....	± .015
Arc Resistance (Arc, ASTM, D-495) (Sec).....	190		

H = Height	2 5/8	2 3/4	2 7/8	3	3 1/8	3 1/4	3 3/8	3 1/2
17.5Flashover Strength - Dry (K.V., S.T.)	40	40	40	40	40	40	40	40
*Dew Flashover Strength (K.V., S.T.) w/o Petticoat	17	17.5	18	18.5	19	19.5	20	20.5
*Dew Flashover Strength (K.V., S.T.) w/ Petticoat	28	28.5	29	29.5	30	30.5	31	31.5
*Impulse (K.V., 1.5 x 40 WAVE) WS	70	74	78	82	86	90	94	98
Weight (lbs.) plus .43 lb. for Petticoat	.65	.70	.75	.80	.85	.90	.95	1.00

*A.S.A. C29.1 — 1961 American Standard Test Method Electrical Power Insulators

Insulators - Molded Polyester Fiberglass
Mechanical and Electrical Properties

Tensile Strength (Pounds)	7,000
Cantilever Strength (Inch Pounds).....	12,000
Compression Strength (Pounds).....	65,000
Torsional Strength (Ft. Pounds).....	150+
Tracking Resistance	
(Arc, ASTM D495) (Sec.)	190
Flame Resistance (ASTM D635).....	Self-Ext.
Creep Distance (Inches)	2 ¹ / ₈ + "H"
Water Absorption (% in 24 hrs.)	
(ASTM D570)	0.28
Height Tolerance.....	±0.015
Maximum Service Temp., Continuous.....	300° F.
Intermittent.....	400° F.

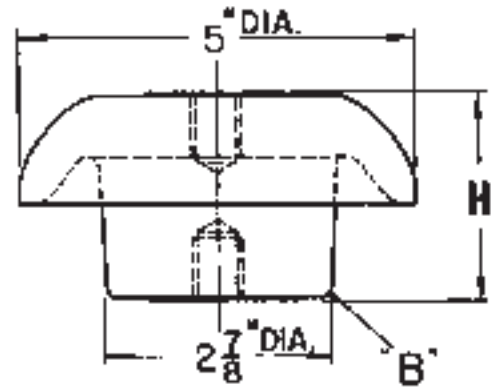

Catalog Information

Tap Size UNC - 2B	"H" = Height - Inches							
	2 ⁵ / ₈	2 ³ / ₄	2 ⁷ / ₈	3	3 ¹ / ₈	3 ¹ / ₄	3 ³ / ₈	3 ¹ / ₂
1/2 - 13	99600-1	99600-4	105956-1	105956-4	105957-1	105957-4	105958-1	105958-4
5/8 - 11	99600-2	99600-5	105956-2	105956-5	105957-2	105957-5	105958-2	105958-5
3/4 - 10	99600-3	99600-6	105956-3	105956-6	105957-3	105957-6	105958-3	105958-6

H = Height	2 ⁵ / ₈	2 ³ / ₄	2 ⁷ / ₈	3	3 ¹ / ₈	3 ¹ / ₄	3 ³ / ₈	3 ¹ / ₂
Dielectric Strength — Dry (K.V., S.T.)	40	40	45	45	50	50	55	55
Dew Flashover Strength (K.V., S.T.)*	31	32	33	34	35	36	37	38
Impulse (K.V., 1.5 x 40 WAVE) WS*	90	94	98	102	106	110	114	118
Weight — Lbs.	2.3	2.4	2.5	2.6	2.7	2.8	2.9	3.0

Material:

Fiberglass reinforced polyester, electrical grade, corrosion resistant, red-poly standard grade #1. Color red.

*ASA C29.1 — 1951 American Standard Test Method Electrical Power Insulators

Insulators - Molded Giant Strain

Application

Giant Strain Insulator is a small rugged insulator. Its small size and high strength makes it suitable for many industrial applications. When equipped with the proper fittings it is used to support conductor angles, tee sections and bars; also when equipped with suitable hardware and clamps they are used for numerous strain applications, such as dead-ending trolley conductor wires or for supporting cables.

Features

Giant Strain Insulators consist of two metal inserts molded in fiberglass reinforced polyester compound of high mechanical and electrical strength. One of the inserts is a cup shaped and the other is machined steel. When assembled they provide an interlocking design of high strength with the compound under compression rather than tensile loading. Relatively large mounting surface for such small insulators provides a substantial bearing for moderate cantilever loads.

Inserts are blind tapped to prevent them from being jacked loose as attaching cap screws are tightened. They are plated for corrosion resistance. Depth of tap is equal to or greater than the diameter.

The 2 $\frac{1}{4}$ " diameter insulator is available with $\frac{1}{2}$ " threads and $\frac{5}{8}$ " threads. They are provided in two styles, the type E having 2 tapped bosses and the type W with one tapped boss and one short threaded stud.



TYPE "W"



TYPE "E"

U. S. Patent #2,967,903

Insulators - Molded Giant Strain

1/2" Series

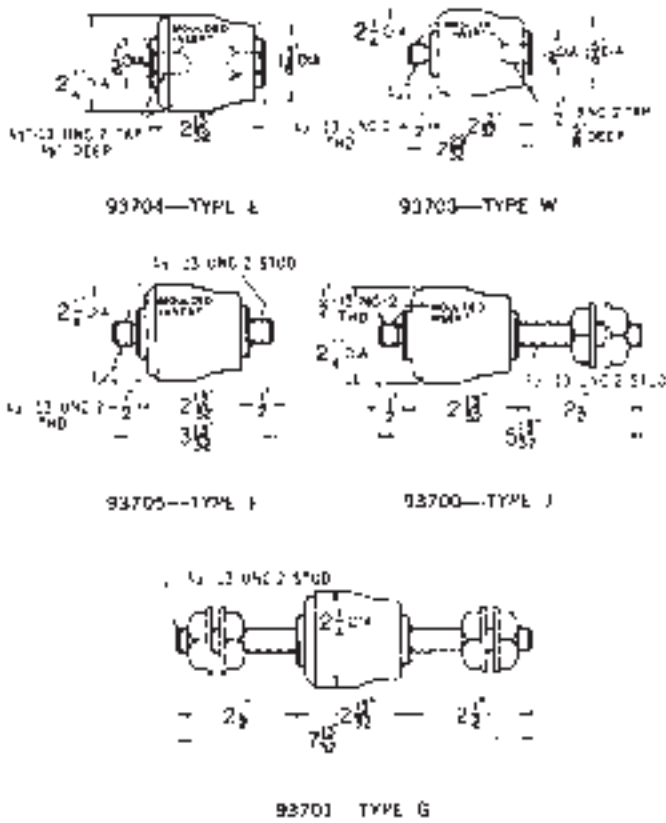

5/8" Series

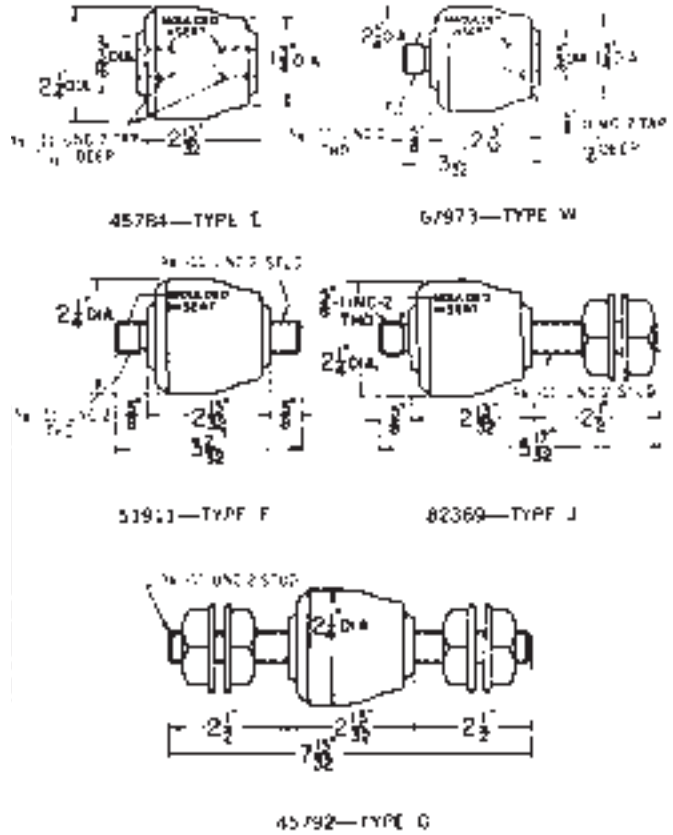

Catalog Information

Insulator Type	Electrical Characteristics			Mechanical Characteristics			Maximum Service Temp Degrees F. †	Net Weight Lbs.	Catalog Number
	Flashover Wet KV.	Dielectric Strength Dry	Leakage Distance Inches	Tensile Strength Lbs.	Cantilever Strength in Lbs.	Compression Strength Lbs.			
1/2" Series									
E	10	20	3	12,000	6,500	30,000	250	3/4	93704
W	10	20	3	12,000	6,500	30,000	250	3/4	93703
F	10	20	3	12,000	6,500	30,000	250	.84	93705
G	10	20	3	12,000	6,500	30,000	250	1.41	93701
J	10	20	3	12,000	6,500	30,000	250	1.16	93700
5/8" Series									
E	10	20	3	15,000	6,500	30,000	250	7/8	45784
W	10	20	3	15,000	6,500	30,000	250	1	67973
F	10	20	3	15,000	6,500	30,000	250	1.08	51911
G	10	20	3	15,000	6,500	30,000	250	2.06	45792
J	10	20	3	15,000	6,500	30,000	250	1.58	82369

† Reduce mechanical values 50% when maximum service temperature is required.

Ordering Directions - Specify by Catalog Number, type and size.

Insulators - Porcelain Corrugated & Petticoat with Inserts

Application

These porcelain insulators are designed for general insulating purposes either indoors or outdoors, particularly where subject to moisture or industrial contaminants. They are suitable for supporting heavy overrunning rails. Other uses are for insulating resistors, bus bars, collectors, critical control conductors or similar industrial application.

Features

These insulators are made of a wet process porcelain body provided with corrugations or extra heavy petticoats to resist breakage and provide maximum leakage distance. Plated iron inserts are bonded into the insulators by means of a special process providing resistance to vibration. Inserts are blind tapped to prevent them from becoming jacked loose as attaching cap screws are tightened. Depth of gap is equal to or greater than the thread diameter.

References

Assemblies using these insulators with proper rail clamps and bases can be used to support overrunning contact rails. When corrugated insulators are mounted horizontally to support light conductor angles, the expansion stud fitting listed on page II-11 should be used to allow movement of the conductor rail due to expansion.

Additional designs of petticoat insulators with various styles of mountings bonded thereon are available.



CORRUGATED

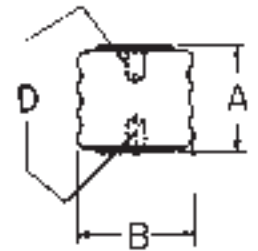

PETTICOAT

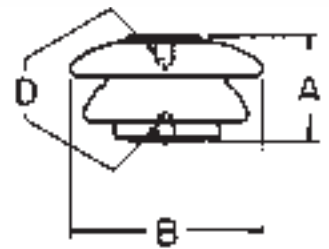

Catalog Information

Dimensions			Electrical Characteristics			Mechanical Characteristics			Maximum Service Temp Degrees F.	Net Weight Lbs.	Catalog Number
A	B	D UNC-2B	Avg. Flashover		Leakage Distance Inches	Tensile Strength Lbs.	Cantilever Strength in Lbs.	Compression Strength Lbs.			
			Dry Kv.	Wet Kv.							
Corrugated Insulators											
3 1/2	3 3/4	5/8 - 11	46	17	4	5000	7500	51000	300	3 1/2	49874
2 5/8	3	1/2 - 13	40	16	3	3000	5000	28000	300	1 5/8	59690
2 5/8	4	5/8 - 11	40	16	3 1/4	3800	5000	37000	300	3 3/8	59695
2 5/8	3	5/8 - 11	40	16	3	3000	5000	28000	300	1 5/8	112168
3 3/8	4 3/4	3/4 - 10	44	17	4 1/16	5000	8300	77000	300	5 3/4	69265
3 3/8	6	1 - 8	44	17	5 1/16	5000	8300	100000	300	11 1/4	74283
Petticoat Insulators											
2 5/8	4 15/16	1/2 - 13	50	20	6.2	3000	4200	25000	300	2 3/4	64658
2 5/8	4 15/16	5/8 - 11	50	20	6.2	3000	4200	25000	300	2 3/4	64672
3 1/2	5 1/2	1/2 - 13	65	29	6.5	3500	6000	30000	300	5 1/4	90638
3 1/2	5 1/2	5/8 - 11	65	29	6.5	3500	6000	30000	300	5 1/4	91376
3 1/2	5 1/2	3/4 - 10	65	29	6.5	3500	6000	30000	300	5 1/4	91694
4	7	1/2 - 13	75	38	9.1	5000	7700	60000	300	7 3/4	93968
4	7	5/8 - 11	75	38	9.1	5000	7700	60000	300	7 3/4	97703
4	7	3/4 - 10	75	38	9.1	5000	7700	60000	300	7 3/4	97704
† Reduce mechanical values 50% when maximum service temperature is required.											

Ordering Directions - Specify by Catalog Number.

Insulators - Porcelain Petticoat with Mountings

Features

These insulator assemblies are similar in design to the petticoat insulators shown on the preceding page except they are provided with plated iron mounting bases and caps for particular requirements. Depth of tap is equal to or greater than the diameter.

References

Wire clamps to support trolley wire conductors with these insulators and other accessories for supporting rigid conductors may be selected.

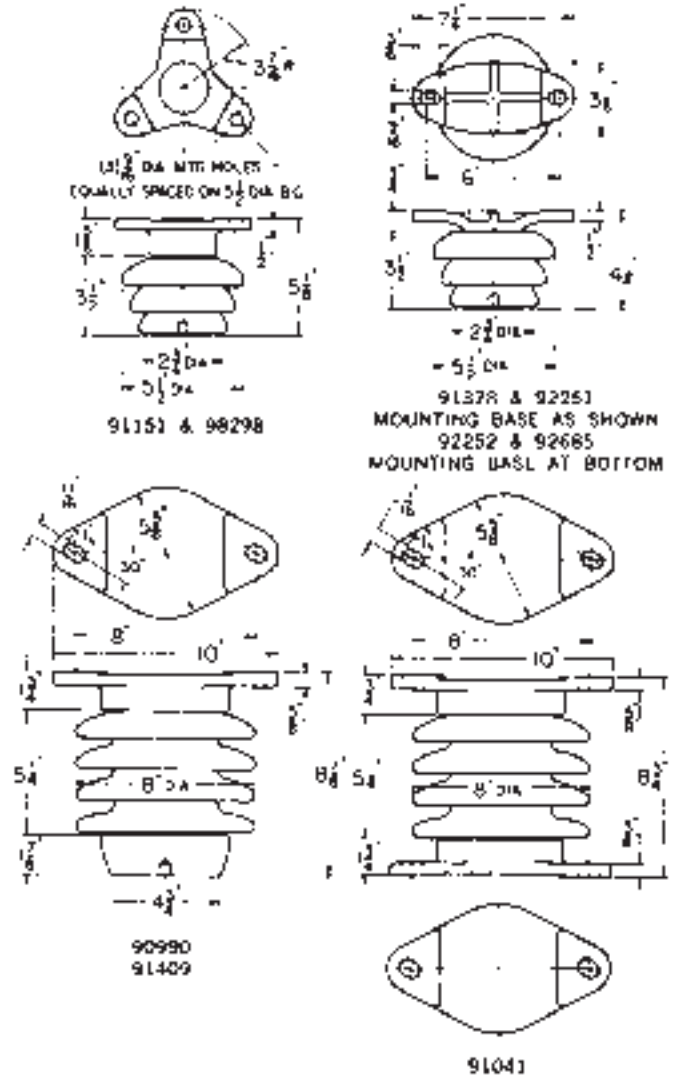

Catalog Information

Insulator Type	Electrical Characteristics			Mechanical Characteristics			Maximum Service Temp Degrees F.	Net Weight Lbs.	Catalog Number
	Flashover Wet KV.	Dielectric Strength Dry	Leakage Distance Inches	Tensile Strength Lbs.	Cantilever Strength in Lbs.	Compression Strength Lbs.			
1/2 - 13	85	55	15.5	10000	21000	40000	300	27 1/4	90990
5/8 - 11	85	55	15.5	10000	21000	40000	300	27 1/4	91409
—	85	55	15.5	10000	21000	40000	300	30 1/4	91041
1/2 - 13	50	25	6.3	4000	6600	40000	300	9 1/2	91151
5/8 - 11	50	25	6.3	4000	6600	40000	300	9 1/2	98298
1/2 - 13	50	25	6.3	4000	5800	40000	300	7 1/2	91378
5/8 - 11	50	25	6.3	4000	5800	40000	300	7 1/2	92251
1/2 - 13	50	25	6.3	4000	5800	40000	300	7 1/2	92252
5/8 - 11	50	25	6.3	4000	5800	40000	300	7 1/2	92685

Ordering Directions - Specify by Catalog Number, type and size.

**Insulators - Porcelain
Giant Strain**

Application

Porcelain covered Giant Strain insulators are designed for general use where high values of tensile strength are required in outside applications or in atmospheres which make the superior qualities of wet process porcelain desirable. These units provide the strength, compactness, and reliability of the Giant Strain insulator with the water-proofing and non-arc tracking characteristics of wet-process porcelain. They are suitable for supporting heavy loadings in tension or compression in combination with vibration and shock. They are used for rugged strain and support applications, including suspension of heavy conductor rail sections for ore bridge and unloader installations.



Features

Porcelain covered Giant Strain insulators consist of a standard fiberglass reinforced polyester insulating strain unit which is sealed into a brown glazed wet-process jacket with a new improved epoxy resin-polysulfide rubber compound. Inner strain unit uses inter-locking steel members designed to transpose a high tensile loading into compressive reaction which can be safely accommodated by central restrained fiberglass reinforced polyester insulating sections. This feature provides extra protection against release of the load if severe overstress occurs.

Outer seal is resilient throughout extreme changes in temperature and chemical exposure, and thereby affords extra protection against breakage of the porcelain jacket. The jacket is so effectively bonded to the inner member that portions of the jacket, if broken, remain attached to the seal providing for the ultimate in safety to personnel. Quality of bond obtained in the seal assures maintenance of the original electrical striking distance despite long exposure to the elements. All fittings are plated.

Reference

See insulator assembly section for assemblies complete with eyes and clevises or with rail support fittings.

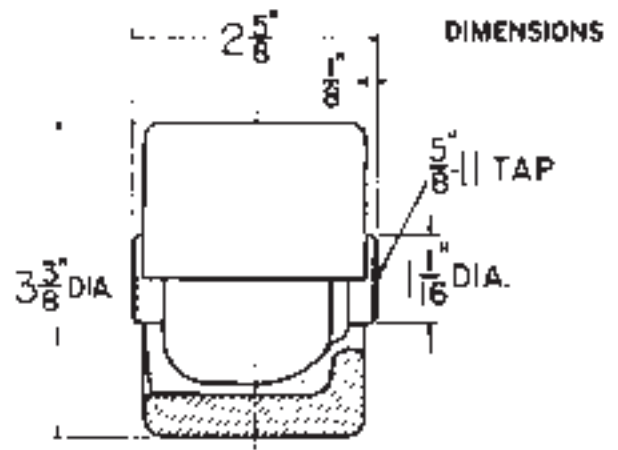

Catalog Information

Max./ System voltage AC or DC	Electrical Characteristics			Mechanical Characteristics				Service Temp De-grees F.	Net Weight Lbs.	Catalog Number
	Dielectric Strength Dry Kv.	Wet Flash-over Kv.	Leakage Distance Inches	Tensile Strength Lbs.	Cantilever Strength in Lbs.	Compression Strength Lbs.	Insert Rotation Resistance Ft. Lbs			
1000	20	10	4 ³ / ₄	12000	4200	40000	50	- 30° to 200°	2	62436

Ordering Directions - Specify by Catalog Number.

Insulators - Molded Giant Strain Type

Application

Giant strain insulators with suitable hardware are used to support electrical cables such as feeder lines in industrial plants, for dead ending wire used as conductors and similar applications.

Features

Assemblies listed in detail on the following pages, some of which are shown below, are assembled from the following major components.

1/2" Series	Component	5/8" Series
93703	Insulator with Stud & Boss	67973
93194	Strain Eye	89149
63449	Strain Clevis	90092
75525	Short Stud	94635
90668	Long Stud	90669
76081	Extra Long Stud	76270

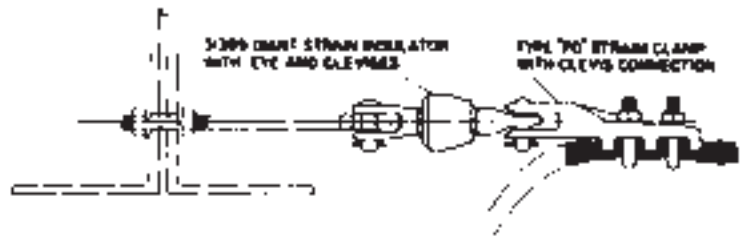

GIANT STRAIN INSULATOR WITH TYPE PD STRAIN CLAMP COMBINED WITH A CONVENTIONAL EYE BOLT SUPPORTING A HEAVY FEEDER CABLE.

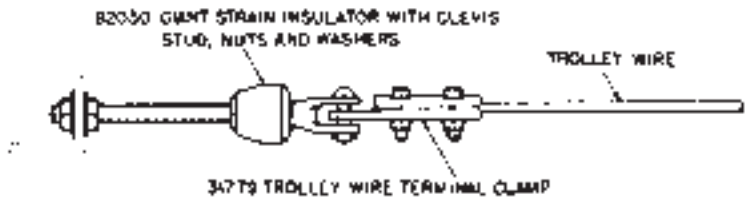

GIANT STRAINER INSULATOR WITH A TROLLEY TERMINAL CLAMP USED FOR "DEAD-ENDING" TROLLEY WIRE CONDUCTORS.

Typical Assemblies

1/2" Series

5/8" Series



93851



31389



93853



94706



94704



46281

Insulators - Molded

1/2" Strain Insulators

Dimensions

2" Diameter Insulators
 750 Volt-Maximum Service
 5600# Safe Working Load

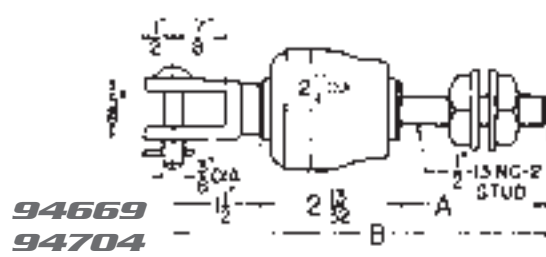
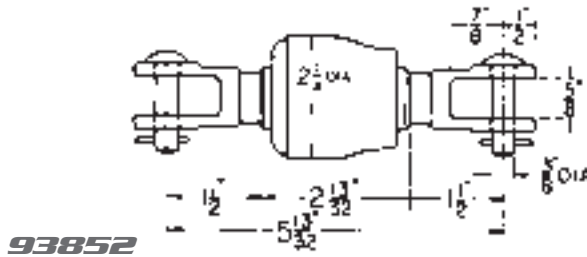
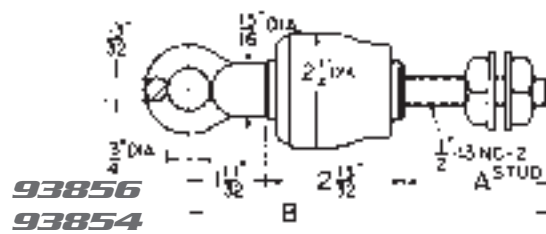
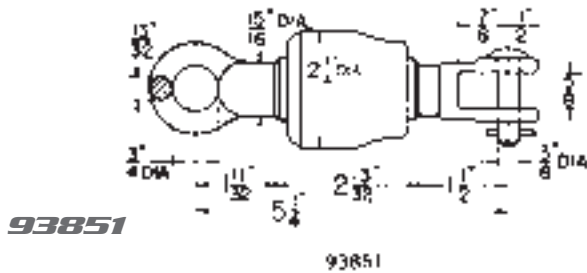
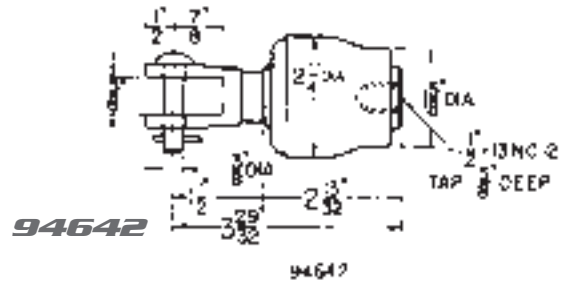
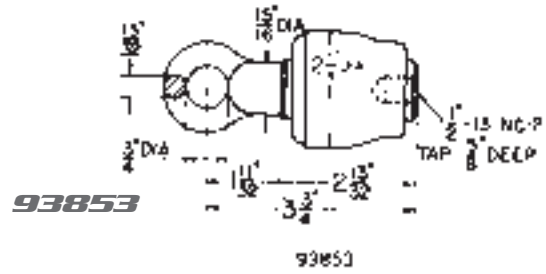
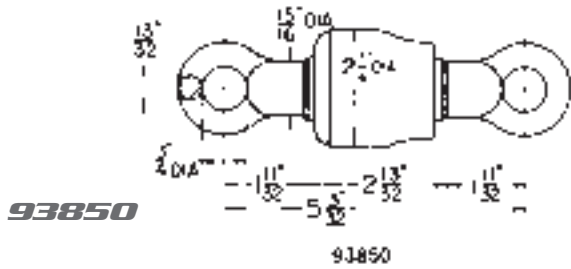

Catalog Information

Description	Standard Package	Net Wt. Each — Lbs.	Catalog No.
with Two eyes	25	1.38	93850
with Strain Clevis & Eye	25	1.41	93851
with Two Strain Clevises	25	1.44	93852
with Eye and Tapped Boss	25	1.06	93853
with Eye and Long Stud — A-2 1/2" — B-6 1/4"	25	1.41	93854
with Eye and Extra Long Stud — A-6" — B-9 3/4"	20	1.56	93856
with Strain Clevis and Tapped Boss	25	1.09	94642
with Strain Clevis and Long Stud — A-2 1/2" — B-6 13/32"	25	1.44	94669
with Strain Clevis and Extra Long Stud — A-6" — B-9 29/32"	20	1.59	94704

Ordering Directions - Specify by Catalog Number.

Insulators - Molded

5/8" Strain Insulators

Dimensions

2 1/4" Diameter Insulators
 750 Volt-Maximum Service
 9,000# Safe Working Load

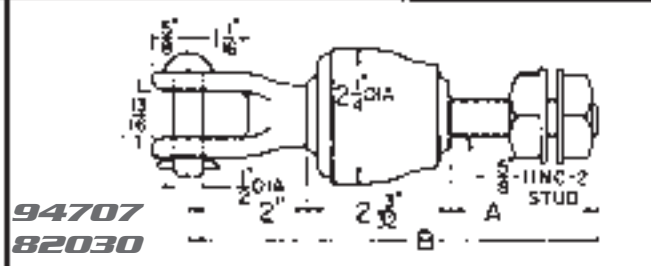
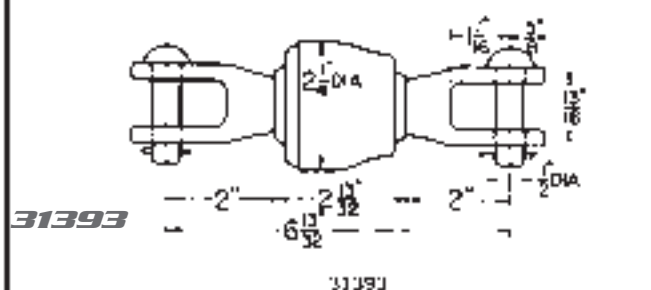
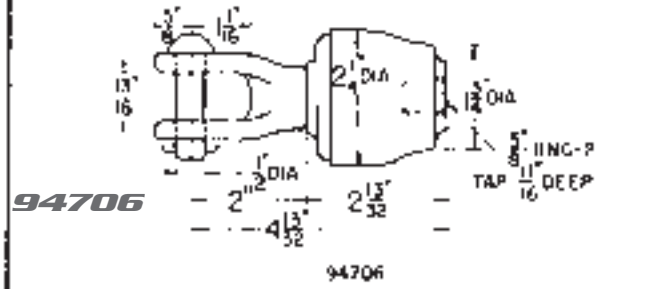
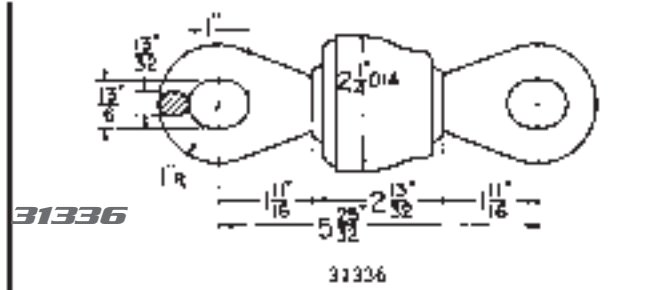
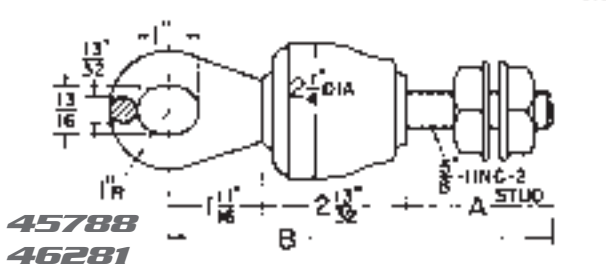
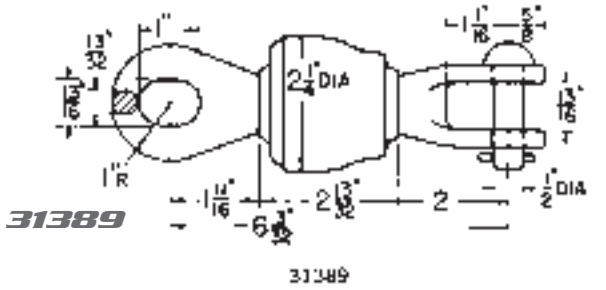
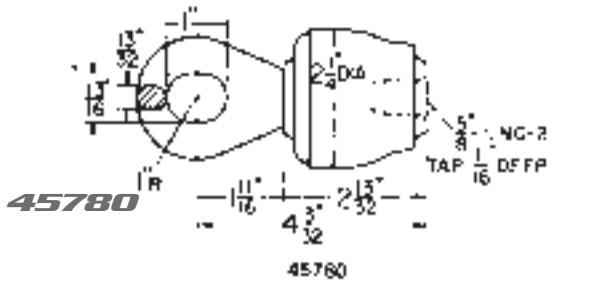

Catalog Information			
Description	Standard Package	Net Wt. Each — Lbs.	Catalog No.
with Two eyes	25	2.00	31336
with Strain Clevis & Eye	25	2.25	31389
with Two Strain Clevises	25	2.50	31393
with Eye and Tapped Boss	25	1.46	45780
with Eye and Long Stud — A-2 1/2" — B-6 19/32"	25	2.16	45788
with Eye and Extra Long Stud — A-7" — B-11 13/32"	25	2.35	46281
with Strain Clevis and Tapped Boss	25	1.69	94706
with Strain Clevis and Long Stud — A-2 1/2" — B-6 29/32"	25	2.27	94707
with Strain Clevis and Extra Long Stud — A-7" — B-11 13/32"	12	2.58	82030

Ordering Directions - Specify by Catalog Number.

**Insulators - Molded
Porcelain Covered Giant Strain Insulators**

Application

Porcelain covered Giant Strain insulators are designed for general use where high values of tensile strength are required in outside applications as in atmospheres which make the superior qualities of wet process porcelain desirable.

These units provide the strength, compactness, and reliability of the Giant Strain insulator with the water-proofing and non-arc tracking characteristics of wet-process porcelain.

They are suitable for supporting heavy loadings in tension in combination with vibration and shock. They are used for rugged strain applications.

Features

Porcelain covered Giant Strain insulators consist of a polyester strain insulator which is sealed into a brown glazed wet-process jacket with a new improved epoxy resin-polysulfide rubber compound. Inner strain unit uses inter-locking steel members designed to transpose a high tensile loading into compressive reaction which can be safely accommodated by central restrained polyester insulating sections. This feature provides extra protection against release of the load if severe overstress occurs.

Outer seal is resilient throughout extreme changes in temperature and chemical exposure, and thereby affords extra protection against breakage of the porcelain jacket. Jacket is so effectively bonded to the inner member, that portions of the jacket, if broken, remain attached to the seal providing for ultimate in safety to personnel. Quality of bond obtained in the seal assures maintenance of the original electrical striking distance despite long exposure to the elements.

All fittings are malleable, zinc plated, and are mounted on $\frac{5}{8}$ " diameter zinc plated studs.

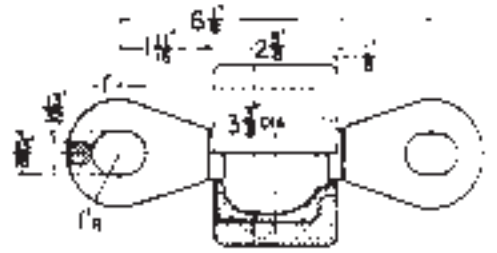

Strain Type 61348

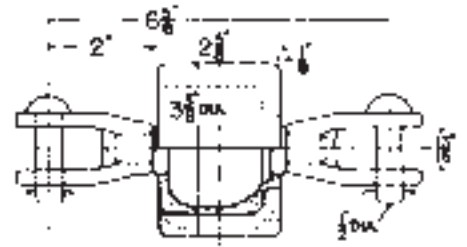

Strain Type 61349

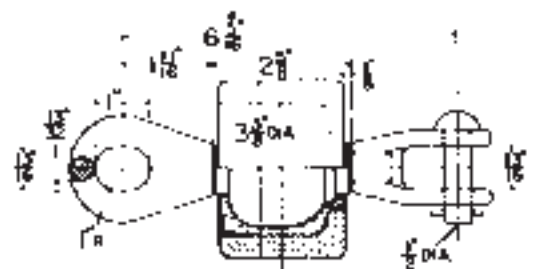

Strain Type 61350

Catalog Number									
Description	Electrical Characteristics				Mechanical Characteristics		Maximum Service Temp. Degrees F°	Net Wt. Each Lbs.	Catalog Number
	Flashover Wet Kv.	Dry Dielectric KV.	Leakage Distance Inches	Max. Sys. Voltage AC or DC V.	Tensile Strength Lbs.	Insert Rotation Resistance Ft. Lbs.			
with two eyes	10	20	4 ³ / ₄	1000	10000	50	200	2.95	61348
with two clevises	10	20	4 ³ / ₄	1000	10000	50	200	3.40	61349
with eye and clevises	10	20	4 ³ / ₄	1000	10000	50	200	3.20	61350

Ordering Directions - Specify by Catalog Number.

Insulators - Molded Spool & Bracket

Application

Spool insulators are used for supporting trolley wire conductors in a "pick-up" type system supplying current to electric cranes. Collectors attached to the cranes make contact by picking up the conductor wires which are supported on these spool and bracket type insulators.

Features

Spool insulators are made from red molded composition. Bracket insulator is made from brown glazed porcelain.

The molded composition spool insulator has greater mechanical strength than the porcelain spool. Wire grooves are wide and deep to provide considerable movement of the conductor wire. Composition spool insulator with bolt differs from the others in that it is provided with a 1/2 inch diameter bolt permanently molded therein and supplied with a nut and washer minimizing the possibility of spools working loose due to vibration.

Molded Composition Type



45501

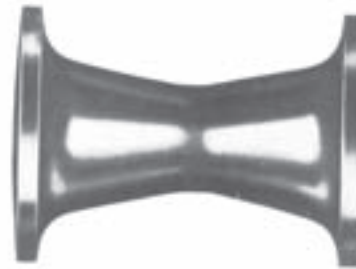
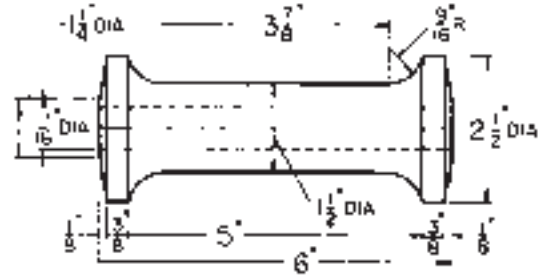

45553

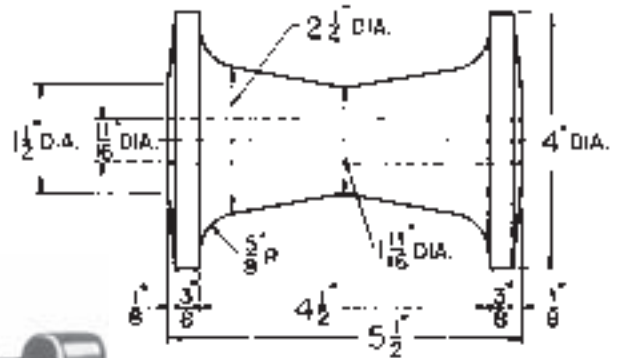

47226

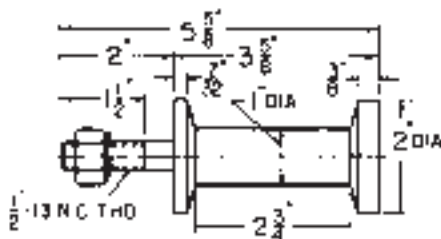

46230

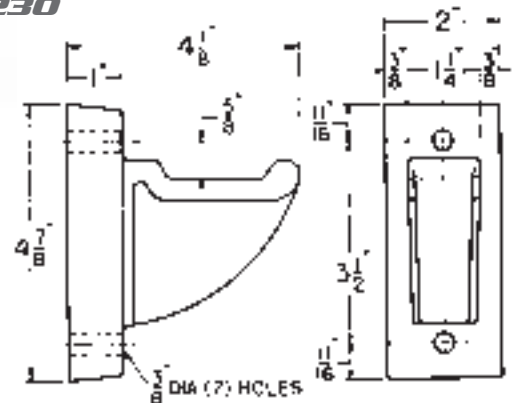

46230

Catalog Information

Description	Approx. Wt. Lbs.	Catalog No.
Composition Spool Insulator	.56	45501
Composition Spool Insulator	1.25	45553
Composition Spool Insulator with Bolt	.56	47226
Porcelain Bracket Insulator	1.25	46230

Ordering Directions - Specify by Catalog Number.

Insulators - Molded Suspension Type

Application

The suspension insulators shown on this page are rugged insulators intended for use with suitable accessories to support crane runway conductors such as wire, bars, tees and angles.

Features

Bodies of all suspension insulators are galvanized malleable iron castings. A "Parkerized" finished steel $\frac{5}{8}$ -11 threaded stud insert with integral bearing surface is molded into the body of each with a thermo-setting insulating compound molded to form generous petticoats.

There are two sizes, the larger type K with a body diameter of $3\frac{5}{8}$ " and consequently a greater leakage distance between the stud and the body. Smaller type F insulator having a shorter leakage distance is used where space conditions are limited and where moisture and industrial contaminants permit.

Type T4 insulator is like the type F4 with mounting holes in a horizontal plane and with minimum extension from mounting surface. When selecting accessories to be used with these insulators make certain to provide adequate clearance to mounting surfaces.

References

With suitable hardware and accessories, these insulators can be used for supporting wire and rigid conductors.



No. 30876 type K2 insulators are for attachment to a horizontal surface.

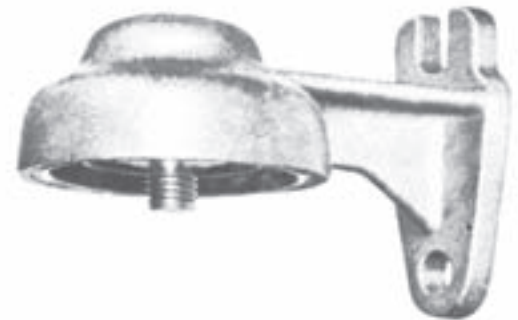
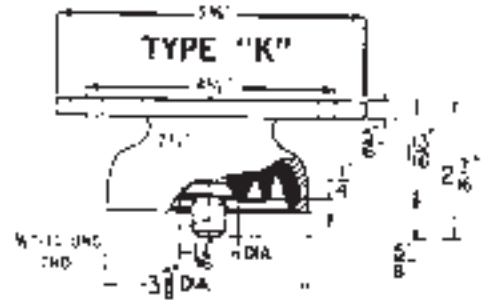

No. 30880 type K4 insulators are designed for attachment to a vertical surface. This insulator will accommodate trolley wire clamps up to and including 5" long.

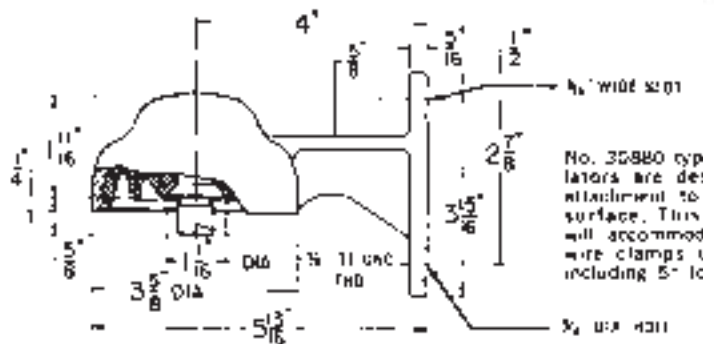

No. 41384 type K8 insulators are a universal form, adaptable to varied mountings; such as pipe suspension fittings, or bolts.

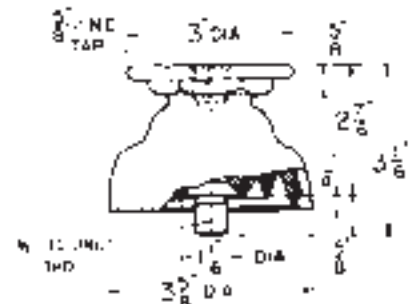

Insulators - Molded Suspension Type

Types F & T

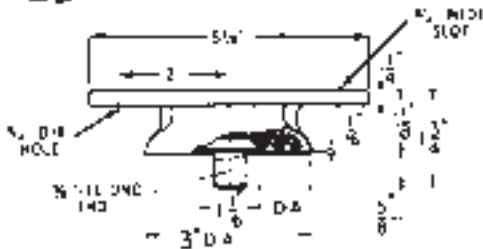

No. 44608 type F2 Insulators are for attachment to a horizontal surface

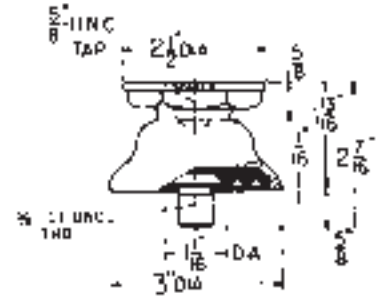

No. 44448 type F8 insulators are a universal form, adaptable to varied mountings; such as pipe suspension fittings, or bolts.

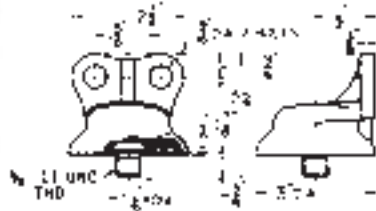
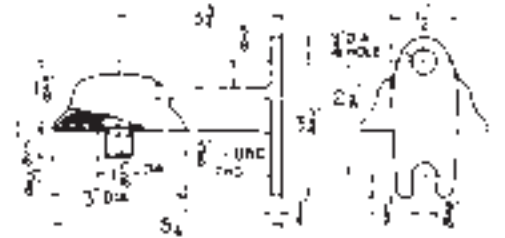

No. 90766 type 14 insulators are designed for attachment to a vertical surface. Mounting holes are in a horizontal plane and with minimum extension from the mounting surface.

No. 49692 type F4 insulators are designed for attachment to a vertical surface. This insulator will accommodate trolley wire clamps up to and including 5" long.

Catalog Number								
Type	Electrical Characteristics			Mechanical Characteristics		†Maximum Service Temp. Degrees F°	Net Wt. Lbs.	Catalog Number
	Dry Flashover Kv.	Wet Flashover KV.	Leakage Distance Inches	Tensile Strength Lbs.	Cantilever Strength In — Lbs.			
K2	20	14	2.3	15000	6500	250	2.62	30876
K4	20	14	2.3	15000	6500	250	2.82	30880
K8	20	14	2.3	15000	6500	250	2.68	41384
F2	15	6	.94	12000	5000	250	1.31	44608
F4	15	6	.94	12000	5000	250	1.94	49692
F8	15	6	.94	12000	5000	250	1.50	44448
T4	15	6	.94	12000	5000	250	1.43	90766

† Reduce mechanical value 50% when maximum service temperature is required.

Ordering Directions - Specify by Catalog Number.

***Insulators - Assemblies
Overtopping
Conductors, Contact
Rail B Series***

Application

These insulators are designed for supporting conventional ASCE rail sections when used as contact rail conductors when collectors are operating in an over-running position.

Features

These designs consist of a bolted assembly of various types of insulators plus mounting bases and rail supports. All types are provided with interlocking notched clamps adjustable to accommodate different rail sizes and permit horizontal alignment. Clamps are designed to permit free movement of the conductor rail to allow for expansion due to temperature changes. Insulator assemblies can be used on circuits up to 5KV. For detailed electrical and mechanical characteristics of the individual insulators see Insulator section of catalog. Assemblies are listed both with and without mounting bases to suit the particular installation requirements. Mounting bases are supplied with slots to accommodate 1/2" mounting bolts except assemblies using 6" diameter corrugated porcelain insulators where 5/8" mounting bolts are used. On assemblies without bases the T dimension or thickness of mounting surface must be specified to determine length of bolt.

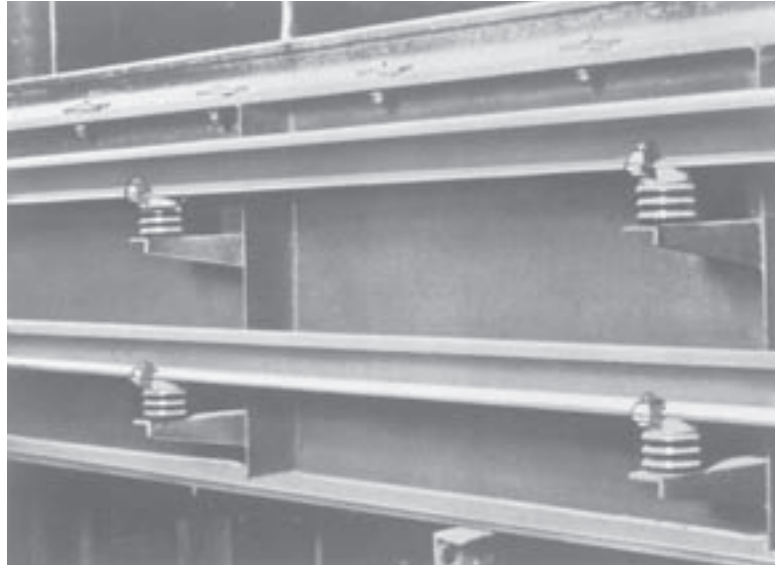

**Corrugated Porcelain
Insulator Assembly**



**Polyester Fiberglass
Insulator Assembly**



**Petticoat Porcelain
Insulator Assembly**



**Petticoat Polyester
Fiberglass
Insulator Assembly**

**Insulator Assemblies
Overrunning Conductors
Contact Rail B Series**

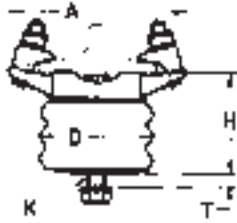

Figure 1
With Corrugated
Porcelain Insulators



Figure 2
With 64672 Petticoat
Porcelain Insulator

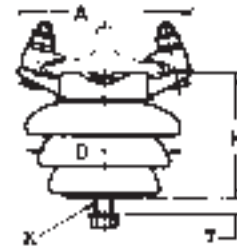

Figure 3
With 91376 and 91694
Petticoat Porcelain
Insulator

**Porcelain Rail Supports Without Mounting Base
With Corrugated Porcelain Insulator Units**

Rail Sizes Lbs. per Yd. A.S.C.E.	Insulator Number	Figure Number	Insulator Diameter D	Dimensions in Inches			Cantilever Strength Inch Lbs.	Net Weight Lbs.	Catalog Number
				A	H	K			
12 to 30	63326	1	3"	5"	3 ⁵ / ₈ "	5 ⁵ / ₈ " - 11	4350	4.25	59667
12 to 30	49874	1	3 ¹ / ₄ "	5"	4 ¹ / ₂ "	5 ⁵ / ₈ " - 11	6750	5.75	64110
12 to 30	59695	1	4"	5"	3 ⁵ / ₈ "	5 ⁵ / ₈ " - 11	4350	5.00	59671
12 to 30	69265	1	4 ³ / ₄ "	5"	4 ³ / ₈ "	3 ³ / ₄ " - 10	7450	8.25	99913
35 to 60	49874	1	3 ³ / ₄ "	6 ¹ / ₄ "	4 ¹ / ₂ "	5 ⁵ / ₈ " - 11	6750	6.50	64112
35 to 60	59695	1	4"	6 ¹ / ₄ "	3 ⁵ / ₈ "	5 ⁵ / ₈ " - 11	4350	6.00	59673
35 to 60	69265	1	4 ³ / ₄ "	6 ¹ / ₄ "	4 ³ / ₈ "	3 ³ / ₄ " - 10	7450	8.75	69249
50 to 100	59695	1	4"	8"	3 ⁵ / ₈ "	5 ⁵ / ₈ " - 11	4350	8.00	99911
60 to 100	69265	1	4 ³ / ₄ "	8"	4 ³ / ₈ "	3 ³ / ₄ " - 10	7450	10.00	69250
60 to 100	74283	1	6"	8"	4 ³ / ₈ "	1" - 8	7450	11.50	76630
70 to 100	74283	1	6"	8"	4 ³ / ₈ "	1" - 8	7450	13.00	99920
70 to 100	59695	1	4"	8"	3 ⁵ / ₈ "	5 ⁵ / ₈ "	4350	7.00	99912
110 to 152	74283	1	6"	9 ¹ / ₂ "	4 ³ / ₈ "	1"	7450	13.00	74269

**Porcelain Rail Supports Without Mounting Base
With Porcelain Petticoat Insulator Units**

12 to 30	64672	2	4 ¹⁵ / ₁₆ "	5"	3 ⁵ / ₈ "	5 ⁵ / ₈ " - 11	1000	5.00	98968
35 to 60	91376	3	5 ¹ / ₂ "	6 ¹ / ₄ "	4 ¹ / ₂ "	5 ⁵ / ₈ " - 11	1200	8.25	98969
65 to 100	91694	3	5 ¹ / ₂ "	8"	4 ¹ / ₂ "	3 ³ / ₄ " - 10	1200	9.50	98970

Note: When ordering specify "T" dimension to insure proper bolt length

**Insulator Assemblies
Overrunning Conductors
Contact Rail B Series**

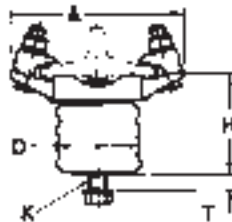

Figure 1
With Corrugated
Polyester Fiberglass Insulator

Polyester Fiberglass Rail Supports Without Mounting Base With Corrugated Polyester Fiberglass Insulator									
Rail Sizes Lbs. per Yd. A.S.C.E.	Insulator Number	Figure Number	Insulator Diameter D	Dimensions in Inches			Cantilever Strength Inch Lbs.	Net Weight Lbs.	Catalog Number
				A	H	K*			
12 to 30	88678	1	3"	5"	3 ⁵ / ₈ "	⁵ / ₈ " - 11	7975	4.00	91794
12 to 30	106601	1	3"	5"	3 ³ / ₄ "	⁵ / ₈ " - 11	8250	4.07	106675
12 to 30	106594	1	3"	5"	3 ⁷ / ₈ "	⁵ / ₈ " - 11	8525	4.14	106676
12 to 30	106348	1	3"	5"	4"	⁵ / ₈ " - 11	8800	4.21	106351
12 to 30	105695	1	3"	5"	4 ¹ / ₈ "	⁵ / ₈ " - 11	9075	4.28	106677
12 to 30	106596	1	3"	5"	4 ¹ / ₄ "	⁵ / ₈ " - 11	9350	4.35	106678
12 to 30	105960	1	3"	5"	4 ³ / ₈ "	⁵ / ₈ " - 11	9650	4.42	106352
35 to 60	88678	1	3"	6 ¹ / ₄ "	3 ⁵ / ₈ "	⁵ / ₈ " - 11	7975	4.75	91795
35 to 60	106601	1	3"	6 ¹ / ₄ "	3 ³ / ₄ "	⁵ / ₈ " - 11	8250	4.82	106679
35 to 60	106594	1	3"	6 ¹ / ₄ "	3 ⁷ / ₈ "	⁵ / ₈ " - 11	8525	4.89	106680
35 to 60	106348	1	3"	6 ¹ / ₄ "	4"	⁵ / ₈ " - 11	8800	4.96	106353
35 to 60	106595	1	3"	6 ¹ / ₄ "	4 ¹ / ₈ "	⁵ / ₈ " - 11	9075	5.03	106681
35 to 60	106596	1	3"	6 ¹ / ₄ "	4 ¹ / ₄ "	⁵ / ₈ " - 11	9350	5.10	106682
35 to 60	105960	1	3"	6 ¹ / ₄ "	4 ³ / ₈ "	⁵ / ₈ " - 11	9650	5.17	106354
65 to 100	88678	1	3"	8"	3 ⁵ / ₈ "	⁵ / ₈ " - 11	7975	5.00	106350
65 to 100	106601	1	3"	8"	3 ³ / ₄ "	⁵ / ₈ " - 11	8250	5.07	106683
65 to 100	106594	1	3"	8"	3 ⁷ / ₈ "	⁵ / ₈ " - 11	8525	5.14	106684
65 to 100	106348	1	3"	8"	4"	⁵ / ₈ " - 11	8800	5.21	106373
65 to 100	106595	1	3"	8"	4 ¹ / ₈ "	⁵ / ₈ " - 11	9075	5.28	106685
65 to 100	106596	1	3"	8"	4 ¹ / ₄ "	⁵ / ₈ " - 11	9350	5.35	106686
65 to 100	105960	1	3"	8"	4 ³ / ₈ "	⁵ / ₈ " - 11	9650	5.42	106374

* Assemblies available with ¹/₂ - 13 or ³/₄ - 10 inserts upon request.
Note: When ordering specify "T" dimension to insure proper bolt length

**Insulator Assemblies
Overrunning Conductors
Contact Rail B Series**

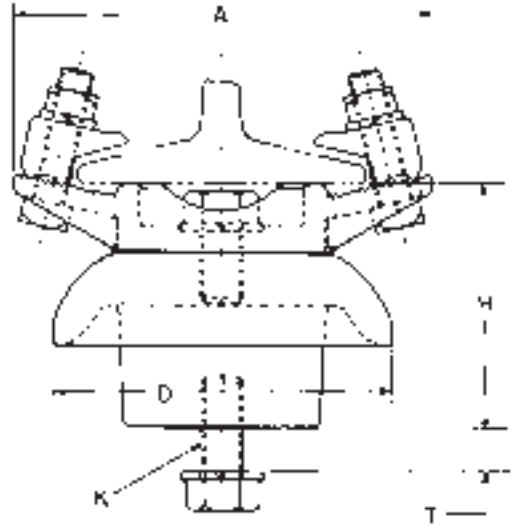

Figure 1
With Petticoat
Polyester Fiberglass Insulator

Polyester Fiberglass Rail Supports Without Mounting Base With Petticoat Polyester Fiberglass Insulator									
Rail Sizes Lbs. per Yd. A.S.C.E.	Insulator Number	Figure Number	Insulator Diameter D	Dimensions in Inches			Cantilever Strength Inch Lbs.	Net Weight Each Lbs.	Catalog Number
				A	H	K*			
12 to 30	99600-2	1	5"	5"	3 ⁵ / ₈ "	⁵ / ₈ " - 11	4350	4.75	99967
12 to 30	99600-5	1	5"	5"	3 ³ / ₄ "	⁵ / ₈ " - 11	4500	4.81	106645
12 to 30	105956-2	1	5"	5"	3 ⁷ / ₈ "	⁵ / ₈ " - 11	4650	4.87	106646
12 to 30	105956-5	1	5"	5"	4"	⁵ / ₈ " - 11	4800	4.93	106335
12 to 30	105957-2	1	5"	5"	4 ¹ / ₈ "	⁵ / ₈ " - 11	4950	4.99	106647
12 to 30	105957-5	1	5"	5"	4 ¹ / ₄ "	⁵ / ₈ " - 11	5100	5.05	106648
12 to 30	105958-2	1	5"	5"	4 ³ / ₈ "	⁵ / ₈ " - 11	5250	5.11	106336
12 to 30	105958-5	1	5"	5"	4 ¹ / ₂ "	⁵ / ₈ " - 11	5400	5.17	106649
35 to 60	99600-2	1	5"	6 ¹ / ₄ "	3 ⁵ / ₈ "	⁵ / ₈ " - 11	4350	5.40	99968
35 to 60	99600-5	1	5"	6 ¹ / ₄ "	3 ³ / ₄ "	⁵ / ₈ " - 11	4500	5.46	106650
35 to 60	105956-2	1	5"	6 ¹ / ₄ "	3 ⁷ / ₈ "	⁵ / ₈ " - 11	4650	5.52	106651
35 to 60	105956-5	1	5"	6 ¹ / ₄ "	4"	⁵ / ₈ " - 11	4800	5.58	106337
35 to 60	105957-2	1	5"	6 ¹ / ₄ "	4 ¹ / ₈ "	⁵ / ₈ " - 11	4950	5.64	106652
35 to 60	105957-5	1	5"	6 ¹ / ₄ "	4 ¹ / ₄ "	⁵ / ₈ " - 11	5100	5.70	106653
35 to 60	105958-2	1	5"	6 ¹ / ₄ "	4 ³ / ₈ "	⁵ / ₈ " - 11	5250	5.76	106338
35 to 60	105958-5	1	5"	6 ¹ / ₄ "	4 ¹ / ₂ "	⁵ / ₈ " - 11	5400	5.82	106654
65 to 100	99600-2	1	5"	8"	3 ⁵ / ₈ "	⁵ / ₈ " - 11	4350	6.10	99969
65 to 100	99600-5	1	5"	8"	3 ³ / ₄ "	⁵ / ₈ " - 11	4500	6.16	106655
65 to 100	105956-2	1	5"	8"	3 ⁷ / ₈ "	⁵ / ₈ " - 11	4650	6.22	106656
65 to 100	105956-5	1	5"	8"	4"	⁵ / ₈ " - 11	4800	6.28	106339
65 to 100	105957-2	1	5"	8"	4 ¹ / ₈ "	⁵ / ₈ " - 11	4950	6.34	106657
65 to 100	105957-5	1	5"	8"	4 ¹ / ₄ "	⁵ / ₈ " - 11	5100	6.40	106658
65 to 100	105958-2	1	5"	8"	4 ³ / ₈ "	⁵ / ₈ " - 11	5250	6.46	106340
65 to 100	105958-5	1	5"	8"	4 ¹ / ₂ "	⁵ / ₈ " - 11	5400	6.52	106659

* Assemblies available with 1/2 -13 or 3/4 - 10 inserts upon request.
Note: When ordering specify "T" dimension to insure proper bolt length

**Insulator Assemblies
Overrunning Conductors
Contact Rail B Series**

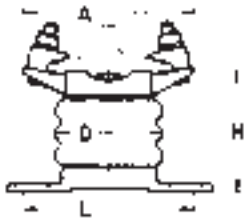

Figure 1
With Corrugated
Porcelain Insulators



Figure 2
With 64672 Petticoat
Porcelain Insulator



Figure 3
With 91376 and 91694
Petticoat Porcelain
Insulator

Slots in Mounting Bases Accommodate 1/2" Bolts.
Slots on 6" Diameter Corrugated Porcelain Assemblies Accommodate 5/8" Bolts.

**Porcelain Rail Supports With Mounting Base
With Corrugated Porcelain Insulator Units**

Rail Sizes Lbs. per Yd. A.S.C.E.	Insulator Number	Figure Number	Insulator Diameter D	Dimensions in Inches		L Dimension		Cantilever Strength Inch Lbs.	Net Weight Lbs.	Catalog Number
				A	H	Min.	Max.			
12 to 30	63326	1	3"	5"	4 1/2"	5"	6 1/4"	4350	5.12	64168
12 to 30	59695	1	4"	5"	4 1/2"	5"	6 1/4"	3750	8.25	59675
12 to 30	69265	1	4 3/4"	5"	5 1/4"	5"	6 1/4"	7450	10.00	72611
12 to 30	49874	1	3 3/4"	5"	5 3/8"	5"	6 1/4"	6750	8.75	64106
35 to 60	59695	1	4"	6 1/4"	4 1/2"	5"	6 1/4"	4350	9	59677
35 to 60	49874	1	3 3/4"	6 1/4"	5 3/8"	5"	6 1/4"	6750	9.5	64108
35 to 60	69265	1	4 3/4"	6 1/4"	5 1/4"	5"	6 1/4"	7450	11.75	72613
50 to 100	59695	1	4"	8"	4 1/2"	5"	6 1/4"	4350	12.25	99952
60 to 100	69265	1	4 3/4"	8"	5 1/4"	5"	6 1/4"	7450	13	72615
60 to 100	74283	1	6"	8"	5 3/8"	7 3/4"	8 1/2"	7650	16.75	98972
110 to 152	74283	1	6"	9 1/2"	5 3/8"	7 3/4"	8 1/2"	7650	18.25	98973

**Porcelain Rail Supports With Mounting Base
With Porcelain Petticoat Insulator Units**

12 to 30	64672	2	4 15/16"	5"	4 1/2"	5"	6 1/4"	1000	800	98977
35 to 60	91376	3	5 1/2"	6 1/4"	5 3/8"	5"	6 1/4"	1200	1125	98978
65 to 100	91694	3	5 1/2"	8"	5 3/8"	5"	6 1/4"	1200	1250	98979

**Insulator Assemblies
Overrunning Conductors
Contact Rail B Series**

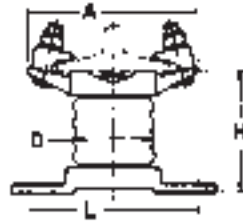

**Figure 1
With Corrugated
Polyester Fiberglass Insulator**

Polyester Fiberglass Rail Supports With Mounting Base With Corrugated Polyester Fiberglass Insulator										
Rail Sizes Lbs. per Yd. A.S.C.E.	Insulator Number	Figure Number	Insulator Diameter D	Dimensions in Inches		L Dimension		Cantilever Strength Inch Lbs.	Net Weight Lbs.	Catalog Number
				A	H	Min.	Max.			
12 to 30	88678	1	3"	5"	4 ¹ / ₂ "	5"	6 ¹ / ₄ "	7975	5.75	95377
12 to 30	106601	1	3"	5"	4 ⁵ / ₈ "	5"	6 ¹ / ₄ "	8250	5.82	106687
12 to 30	106594	1	3"	5"	4 ³ / ₄ "	5"	6 ¹ / ₄ "	8525	5.89	106688
12 to 30	106348	1	3"	5"	4 ⁷ / ₈ "	5"	6 ¹ / ₄ "	8800	5.96	106355
12 to 30	105695	1	3"	5"	5"	5"	6 ¹ / ₄ "	9075	6.03	106689
12 to 30	106596	1	3"	5"	5 ¹ / ₈ "	5"	6 ¹ / ₄ "	9350	6.10	106690
12 to 30	105960	1	3"	5"	5 ¹ / ₄ "	5"	6 ¹ / ₄ "	9650	6.17	106356
35 to 60	88678	1	3"	6 ¹ / ₄ "	4 ¹ / ₂ "	5"	6 ¹ / ₄ "	7975	6.75	90960
35 to 60	106601	1	3"	6 ¹ / ₄ "	4 ⁵ / ₈ "	5"	6 ¹ / ₄ "	8250	6.82	106691
35 to 60	106594	1	3"	6 ¹ / ₄ "	4 ³ / ₄ "	5"	6 ¹ / ₄ "	8525	6.89	106692
35 to 60	106348	1	3"	6 ¹ / ₄ "	4 ⁷ / ₈ "	5"	6 ¹ / ₄ "	8800	6.96	106357
35 to 60	105695	1	3"	6 ¹ / ₄ "	5"	5"	6 ¹ / ₄ "	9075	7.03	106693
35 to 60	106596	1	3"	6 ¹ / ₄ "	5 ¹ / ₈ "	5"	6 ¹ / ₄ "	9350	7.10	106694
35 to 60	105960	1	3"	6 ¹ / ₄ "	5 ¹ / ₄ "	5"	6 ¹ / ₄ "	9650	7.17	106358
65 to 100	88678	1	3"	8"	4 ¹ / ₂ "	5"	6 ¹ / ₄ "	7975	7.75	106359
65 to 100	106601	1	3"	8"	4 ⁵ / ₈ "	5"	6 ¹ / ₄ "	8250	7.82	106695
65 to 100	106594	1	3"	8"	4 ³ / ₄ "	5"	6 ¹ / ₄ "	8525	7.89	106696
65 to 100	106348	1	3"	8"	4 ⁷ / ₈ "	5"	6 ¹ / ₄ "	8800	7.96	106360
65 to 100	105695	1	3"	8"	5"	5"	6 ¹ / ₄ "	9075	8.03	106697
65 to 100	106596	1	3"	8"	5 ¹ / ₈ "	5"	6 ¹ / ₄ "	9350	8.10	106698
65 to 100	105960	1	3"	8"	5 ¹ / ₄ "	5"	6 ¹ / ₄ "	9650	8.17	106361

Slots in mounting base accommodate 1/2" bolts

**Insulator Assemblies
Overrunning Conductors
Contact Rail B Series**

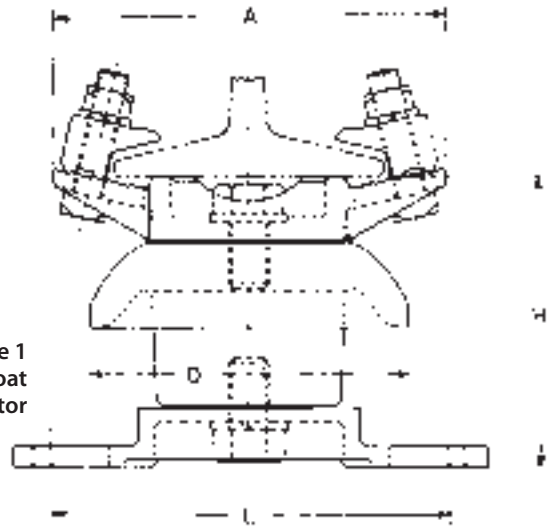

Figure 1
With Petticoat
Polyester Fiberglass Insulator

**Polyester Fiberglass Rail Supports With Mounting Base
With Petticoat Polyester Fiberglass Insulator**

Rail Sizes Lbs. per Yd. A.S.C.E.	Insulator Number	Figure Number	Insulator Diameter D	Dimensions in Inches		L Dimension		Cantilever Strength Inch Lbs.	Net Weight Each Lbs.	Catalog Number
				A	H	Min.	Max.			
12 to 30	99600-2	1	5"	5"	4 ¹ / ₂ "	5"	6 ¹ / ₄ "	4350	6.5	99970
12 to 30	99600-5	1	5"	5"	4 ⁵ / ₈ "	5"	6 ¹ / ₄ "	4500	6.56	106660
12 to 30	105956-2	1	5"	5"	4 ³ / ₄ "	5"	6 ¹ / ₄ "	4650	6.62	106661
12 to 30	105956-5	1	5"	5"	4 ⁷ / ₈ "	5"	6 ¹ / ₄ "	4800	6.68	106341
12 to 30	105957-2	1	5"	5"	5"	5"	6 ¹ / ₄ "	4950	6.74	106662
12 to 30	105957-5	1	5"	5"	5 ¹ / ₈ "	5"	6 ¹ / ₄ "	5100	6.80	106663
12 to 30	105958-2	1	5"	5"	5 ¹ / ₄ "	5"	6 ¹ / ₄ "	5250	6.86	106342
12 to 30	105958-5	1	5"	5"	5 ³ / ₈ "	5"	6 ¹ / ₄ "	5400	6.92	106664
35 to 60	99600-2	1	5"	6 ¹ / ₄ "	4 ¹ / ₂ "	5"	6 ¹ / ₄ "	4350	7.15	99971
35 to 60	99600-5	1	5"	6 ¹ / ₄ "	4 ⁵ / ₈ "	5"	6 ¹ / ₄ "	4500	7.21	106665
35 to 60	105956-2	1	5"	6 ¹ / ₄ "	4 ³ / ₄ "	5"	6 ¹ / ₄ "	4650	7.27	106666
35 to 60	105956-5	1	5"	6 ¹ / ₄ "	4 ⁷ / ₈ "	5"	6 ¹ / ₄ "	4800	7.33	106343
35 to 60	105957-2	1	5"	6 ¹ / ₄ "	5"	5"	6 ¹ / ₄ "	4950	7.39	106667
35 to 60	105957-5	1	5"	6 ¹ / ₄ "	5 ¹ / ₈ "	5"	6 ¹ / ₄ "	5100	7.45	106668
35 to 60	105958-2	1	5"	6 ¹ / ₄ "	5 ¹ / ₄ "	5"	6 ¹ / ₄ "	5250	7.51	106344
35 to 60	105958-5	1	5"	6 ¹ / ₄ "	5 ³ / ₈ "	5"	6 ¹ / ₄ "	5400	7.57	106669
65 to 100	99600-2	1	5"	8"	4 ¹ / ₂ "	5"	6 ¹ / ₄ "	4350	7.85	99972
65 to 100	99600-5	1	5"	8"	4 ⁵ / ₈ "	5"	6 ¹ / ₄ "	4500	7.91	106670
65 to 100	105956-2	1	5"	8"	4 ³ / ₄ "	5"	6 ¹ / ₄ "	4650	7.97	106671
65 to 100	105956-5	1	5"	8"	4 ⁷ / ₈ "	5"	6 ¹ / ₄ "	4800	8.03	106345
65 to 100	105957-2	1	5"	8"	5"	5"	6 ¹ / ₄ "	4950	8.10	106672
65 to 100	105957-5	1	5"	8"	5 ¹ / ₈ "	5"	6 ¹ / ₄ "	5100	8.16	106673
65 to 100	105958-2	1	5"	8"	5 ¹ / ₄ "	5"	6 ¹ / ₄ "	5250	8.22	106346
65 to 100	105958-5	1	5"	8"	5 ³ / ₈ "	5"	6 ¹ / ₄ "	5400	8.28	106674

Slots in mounting base accommodate 1/2" bolts

***Insulators Assemblies
Overrunning Conductors
Types HA, BOA, DDI, and DD***

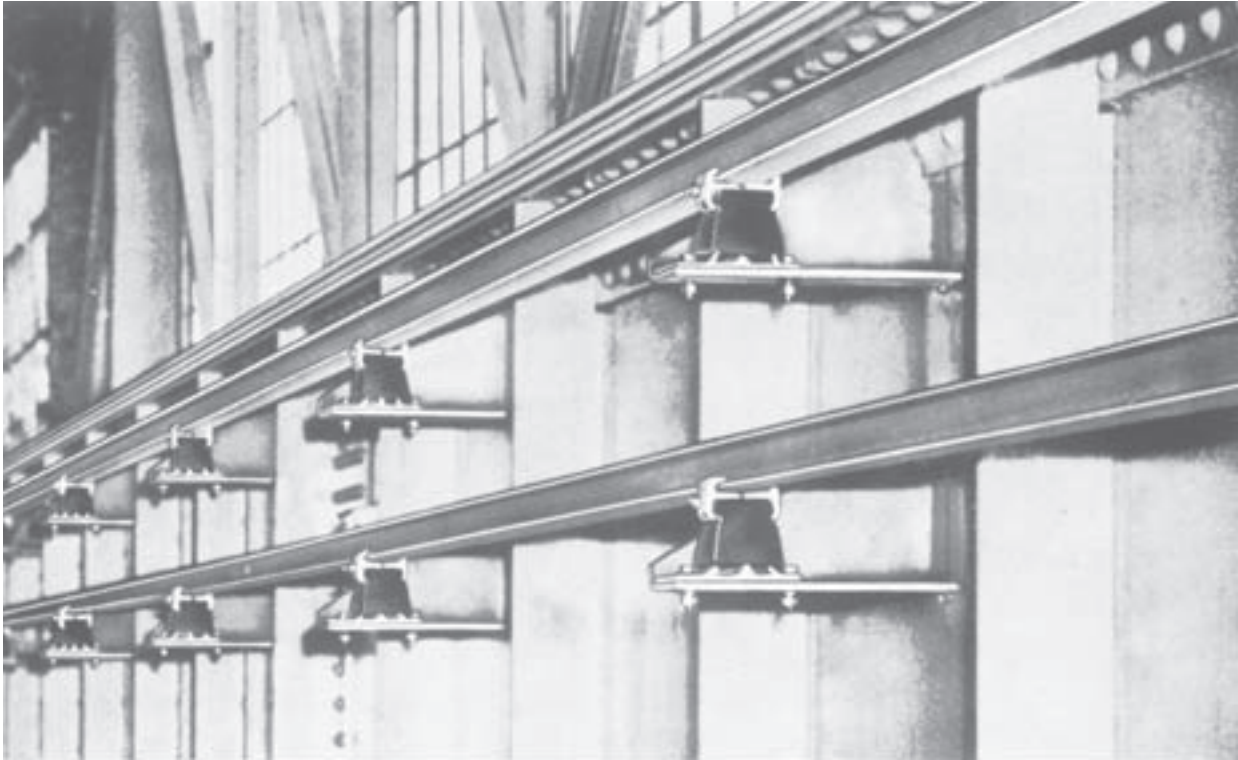

Application

These insulators are designed for supporting conventional ASCE rail sections when used as contact rail conductors when collectors are operating in an overrunning position.

These insulator assemblies differ from the "B" Series previously shown since the mounting bases and, in some cases, the rail supports are cemented to the insulators.

Four types most commonly used are shown, however, other types can also be supplied for various mountings and rail sizes.

Type "HA"



- 48696
- 48697
- 48698
- 48790
- 60444

Type "DD"



- 46519
- 46520

Type "BOA"



- 63045
- 63670

Type "DDI"



- 70463

Insulators Assemblies
Overrunning Conductors - Types HA and BOA

Type HA Features	
Design	<p>Insulator with cast base cemented therein.</p> <p>Rail fittings are clamped to insulator making a rigid assembly.</p> <p>Rail clamps permit free movement of rail to allow for expansion and contraction.</p>
Insulator	Square block of brown glazed dry process porcelain.
Metal Parts	Galvanized

Catalog Information			
For ASCE Rail Size Lbs. per Yd.	Dimension A Inches	Net Wt. Each — Lbs.	Catalog Number
12 - 14	2 ⁵ / ₁₆	7	48696
16	2 ⁵ / ₈	7	48697
20 - 25	3	7	48698
30	3 ³ / ₈	7	48790
30 - 40	3 ³ / ₄	8 ¹ / ₄	60444

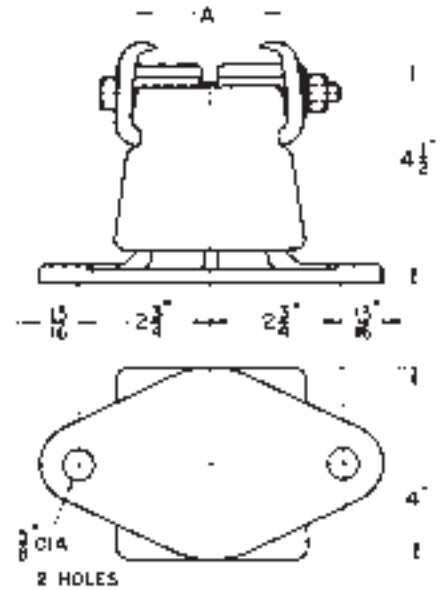

Type BOA Features	
Design	<p>Insulator with base and rail cap cemented thereto making one piece assembly except for rail lugs.</p> <p>Rail clamps permit free movement of rail to allow for expansion and contraction.</p> <p>High strength parts and assembly for use where unusual mechanical strength is required.</p>
Insulator	Petticoat design of brown glazed wet-process porcelain.
Metal Parts	Galvanized

Catalog Information			
For ASCE Rail Size Lbs. per Yd.	Dimension A Inches	Net Wt. Each — Lbs.	Catalog Number
35 - 60	6 ¹ / ₄	10	63045
65 - 100	8	12	63670

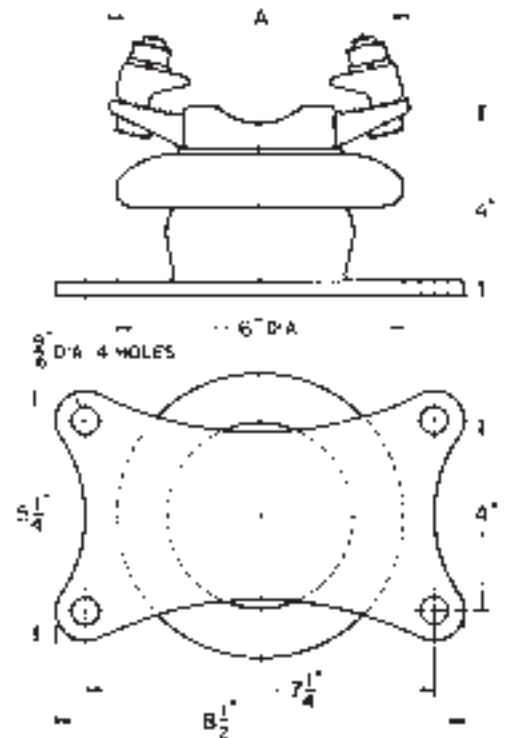

Ordering Directions - Specify by Catalog Number.

Insulators Assemblies

Overrunning Conductors - Types DDI and DD

Type DDI Features	
Design	<p>Large rail mounting cap cemented to top of insulator.</p> <p>Tapped insert cemented to bottom of insulator provides single hole mounting.</p> <p>Rail clamps permit free movement of rail to allow for expansion and contraction.</p>
Insulator	Round block of brown glazed dry process porcelain.
Metal Parts	Galvanized

Catalog Information		
For ASCE Rail Size Lbs. per Yd.	Net Wt. Each — Lbs.	Catalog Number
30 - 40	11½	70463

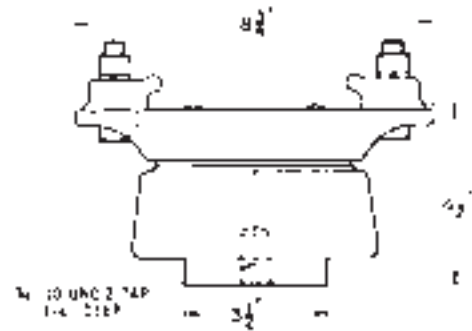

Type DD Features	
Design	<p>Large rail mounting cap cemented to top of insulator.</p> <p>Four hole flat base cemented to bottom of insulator.</p> <p>Rail clamps permit free movement of rail to allow for expansion and contraction.</p>
Insulator	Round block of brown glazed dry process porcelain.
Metal Parts	Galvanized

Catalog Information		
For ASCE Rail Size Lbs. per Yd.	Net Wt. Each — Lbs.	Catalog Number
45 - 65	14	46519
70 - 95	14	46520

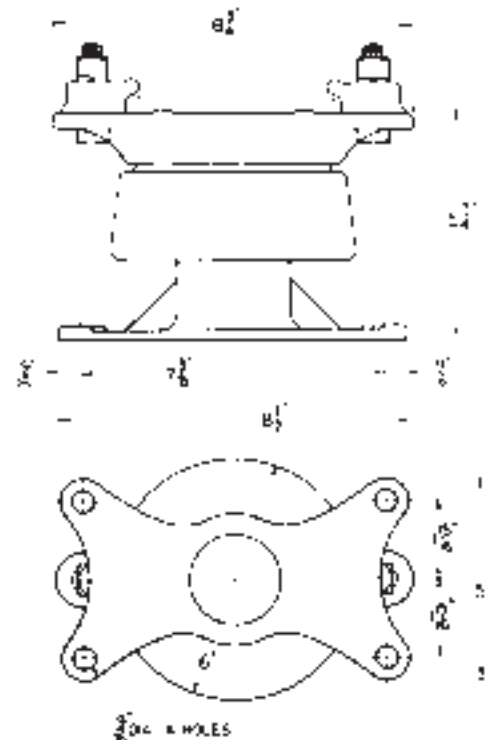

Ordering Directions - Specify by Catalog Number.

Insulators Assemblies Underrunning Conductors

Application

Under-Contact Rail System illustrated is for supporting conventional rail shapes used as conductors in industrial installations of heavy cranes, conveyors and other industrial haulage systems. This type of conductor system is used extensively in steel mills, shipyards, chemical works, coke plants and ore or coal handling systems.

Features

Under-Contact system assures good contact between the collector and the conductor by avoiding the accumulation of dust, dirt, or snow and sleet on the contact surface. No expansion joints are required as the rail conductor is free to move from expansion or contraction.

Installation does not call for highly skilled labor and the number of supports required is reduced to a minimum.

Protection against accidental contact with live rail may be secured by means of a wooden cover or a formed fibre cover, if desired.

This system has been developed using various types of supports, employing standard rail sections.

Various types of supporting standards and brackets for one, two or three rails and for rails of various weights are listed and described separately on pages following.

Component parts are those most commonly used, however other types and other sizes for larger rails are available to order.

Where the contact shoe employed is considerably wider than the contact surface of the rail to allow for horizontal misalignments it is essential that clearance between the contact shoe, rail, insulator and supporting standard or bracket be accurately determined before specifications are written. This will assure adequate electrical and mechanical clearances under conditions of maximum misalignment and contact shoe wear. This is particularly important when the smaller rail sizes are employed.

Suitable underrunning contact rail collectors for use in connection with this system are available.

Weld type feeder connectors are available.



Typical Double Rail Installation



**Assembly of Rail
Standard with Insulator**



**Rail Standard (Cast Iron)
For Mounting or Rail Tie
or horizontal surface.**

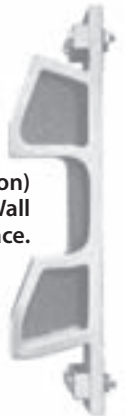

**Rail Bracket (Cast Iron)
For Mounting on Wall
or vertical surface.**



**Insulators
(Polyester Fiberglass or
Brown Glazed Porcelain)
Varying in size to (it rail
selected. Two halves
required per support joint.**

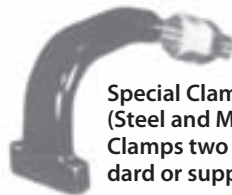

**Special Clamping Bolt
(Steel and Malleable Iron Coated With Insulation)
Clamps two insulators with rail to the rail stan-
dard or support. One required per support point.**

**Insulators Assemblies
Underrunning Conductors
Porcelain Insulators**

Application

These Porcelain Insulators are used with the rail supports and special clamping bolts to insulate and support standard rail from 12 to 152 pounds used as conductors in this system.

They are made of two halves, the inside shaped to support the rail, the outside having recesses to fit lugs in the rail supports and the specially shaped clamping bolts.

Features

Insulators are made of a special quality of porcelain for this service; heavily brown glazed, of high mechanical strength, particularly under compression, and having ample insulating characteristics up to 1000 volts under the worst conditions of exposure to weather.

Insulator No. 77713 is designed to allow space for carrying auxiliary cable or cables along top of the base of the rail. This insulator when used with 60 lb. rail provides space for one 700 MCM bare cable per side or with 70 lb. rail 1000 MCM bare cable per side.

Clamping Bolts

Application

These clamping bolts engage insulator supporting rail and clamp the combination to the supporting structure. All bolts furnished with standard holding nut and lock nut.

Features

Insulated bolts are finished with a tough flexible insulating coating where bolt makes contact with insulator. Flexible coating increases insulation value and provides additional protection to insulator against vibration, mechanical shock or slight misalignment.

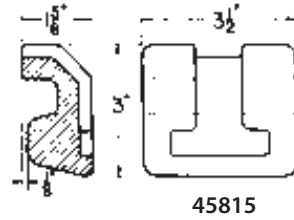

45815

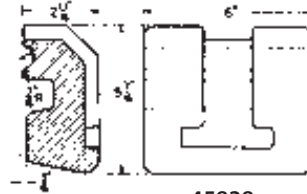

45838



77713

Catalog Information			
ASCE Rail Size Lbs. Per Yd.	Use Insulated Clamping Bolt	Net Weight Each Lbs.	Catalog Number
12 - 30	89618	1	45815
35 - 55	90354	5.25	45838
60 - 70	90354	5.25	77713
Dimensions Not Shown			
80 - 100	105265	7.5	48773
Other Rail Types — Dimensions Not Shown			
112 - 132 (A.R.E.A.)	None	8	48605
60 - 90 (A.R.E.A.)	90354	4.5	41048
132 (A.R.E.A.)	105264	12.5	93341
152 Pa. Standard	105264	13.75	73218
Catalog number applies to one piece or a half, two insulator halves being required for each point of rail support.			

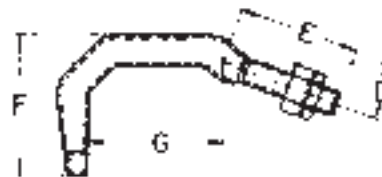
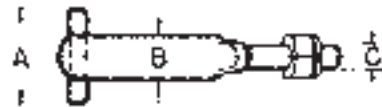

Catalog Information								
Insulated Clamping Bolt	A	B	C	D	E	F	G	Net Wt. each Lbs. Insulated
89618	2	15/16	1/2 - 13	20°	2 1/2	2 11/16	2 7/8	.625
90354	3 1/4	1 5/8	3/4 - 10	15°	3 7/8	4 5/8	3 13/16	2.5
105265	3 1/4	1 5/8	7/8 - 9	15°	4 1/4	5 1/4	4 9/16	3.5
74838	3 1/8	1 1/2	1 - 8	15°	4 3/8	5 7/16	5	—
105264	3 3/8	1 5/8	1 - 8	17° - 15°	4 3/4	7 3/4	4 7/16	5

Ordering Directions - Specify by Catalog Number.

Insulators
Polyester Fiberglass

Application

The Red polyester fiberglass insulator and clamping bolt are used as rail supports for A.S.C.E. and other rails when they are applied as the current carrying conductor in a system.

An assembly is made of two halves, the inside shaped to support the rail. The outside is recessed to accept lugs in the rail support bracket and the specially shaped clamping bolts.

Features

Units are molded from a special compound of polyester resin reinforced with glass fiber to give high impact strength, good electrical properties and a surface finish resistant to weathering.

The use of these insulators can result in a lower over-all cost compared with porcelain insulators due to their high impact strength and chip resistance effecting a very low maintenance factor.

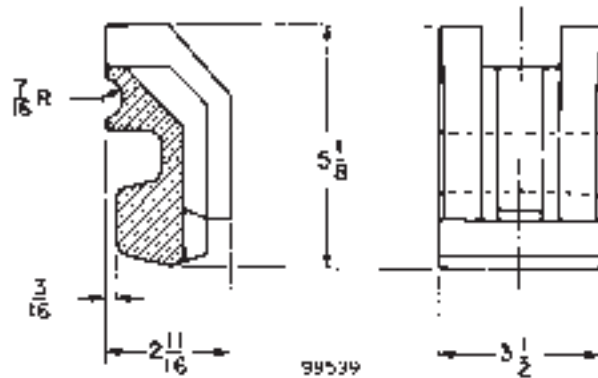

Catalog Information			
ASCE Rail Size Lbs. per Yd.	Use Insulated Clamping Bolt	Net Weight Each Lbs.	Catalog Number
132 AREA	105264	4.5	99796
152 Pa. Standard Double Head	105264	4.5	99796
40 - 70	90354	1.5	99539
Other Rail Types Dimensions Not Shown			

Ordering Directions - Specify by Catalog Number.

Insulators Assemblies Underrunning Conductors

Application

Rail standards and brackets shown illustrate a few of many styles and sizes used as industrial third-rail applications to support conventional rail conductors ranging in size from 12 to 60 pounds.

Features

There are two types; the rail brackets shown on this page, generally mounted on a wall or vertical supporting structure, and the rail standards shown on the next page for use on concrete mountings, railroad ties or other horizontal surfaces. Both types are generally made of cast iron. Some of the rail brackets are provided with a corrugated section around an elongated mounting slot to be used with a corrugated washer to adjust for misalignment of the rail. Some types are available with mounting holes for attaching wooden guard rails. Pattern equipment is available for many types other than those shown in this listing.

Ordering Directions

Catalog numbers shown refer only to the rail standard and corrugated washer, when used, but without insulators or clamping bolts. Specify by catalog number those illustrated or consult office for other styles.

97848

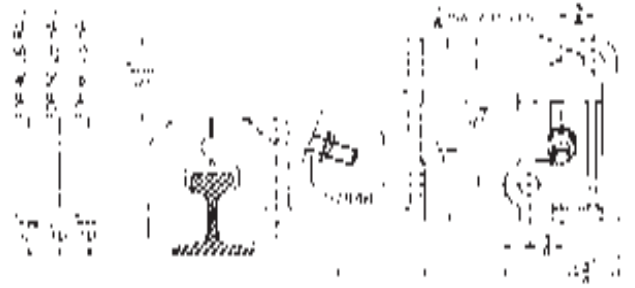

46164



46169



Catalog Information

Description	Used with Rail Sizes Lbs. per Yard		Use Insulator	Use Clamping Bolt	Use Collectors	Net Weight Each - Lbs.	Catalog Number
	A.S.C.E.	A.R.A.					
Single Rail Bracket	35 to 55	35 to 48	45838	90354	L. M. Pony L. M. Standard L. M. I. Pony	12	97848
	40 to 60	60 A, B	77713				
Double Rail Bracket with Washers 46165	35 to 55	35 to 48	45838	90354	L. M. Pony L. M. Standard L. M. I. Pony	48	46164
	40 to 60	60 A, B	77713				
Triple Rail Bracket with Washers 44620	12 to 30	12 to 30	45815	89618	L. M. Pony L. M. I. Pony	30	46169

**Insulators Assemblies
Underrunning Assemblies**

Ordering Directions

Catalog numbers shown refer only to the rail standard and corrugated washer, when used, but without insulators or clamping bolts.

Specify by catalog number those illustrated or consult office for other styles.



46221

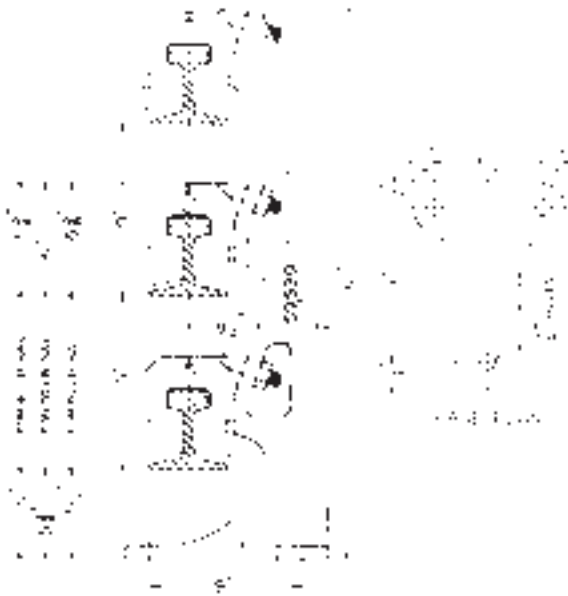

59539



45811

Catalog Information

Description	Used with Rail Sizes Lbs. per Yard		Use Insulator	Use Clamping Bolt	Use Collectors	Approx. Weight Each - Lbs.	Catalog Number
	A.S.C.E.	A.R.A.					
Single Rail Standard	35 to 55	35 to 48	45838	90354	L. M. Pony L. M. Standard L. M. I. Pony	20	46221
	40 to 60	60 A, B	77713				
Double Rail Standard	35 to 55	35 to 48	45838	90354	L. M. Pony L. M. Standard L. M. I. Pony	43	45811
	40 to 60	60 A, B	77713				
Triple Rail Standard	35 to 55	35 to 48	45838	90354	L. M. Pony L. M. I. Pony	75	59539
	40 to 60	60 A, B	77713				

Insulators Assemblies Underrunning Conductors

Application

These rugged assemblies are designed for supporting inverted ASCE rail sections to permit collection of power from the ball face of the rail for underrunning contact applications. This type of installation is commonly employed for ore bridge and unloader cross travel conductors and on main runway conductors for this class of heavy duty equipment.

Assemblies employ the No. 62436 Porcelain Covered Giant Strain Insulator.

This insulator has superior tensile strength and weathering characteristics, resulting from the combination of a special molded interior strain assembly encased by a rugged brown wet-process porcelain outer jacket.

Insulators may be used on 12 to 60 pound ASCE rails on insulator spacings of ten feet, and for applications up to 1000 V. AC or DC.

Features

Assemblies consist of rail base with adjustable clips, mounting bases of the two styles shown and the Porcelain Covered Giant Strain Insulator. All fittings are of malleable iron, hot galvanized. Rail base clip combinations are designed to permit free movement of the rails, accommodating expansion and contraction with minimum insulator stress.

Catalog Information			
For ASCE Rails Lbs. per Yd.	A Dimension	Net Weight Lbs.	Catalog Number
35 - 60	6 ¹ / ₄ "	8 ¹ / ₈	63462
35 - 60	6 ¹ / ₄ "	8 ³ / ₈	76681
12 - 30	5"	7	63461
12 - 30	5"	7 ¹ / ₄	76956

Ordering Directions - Specify by Catalog Number.

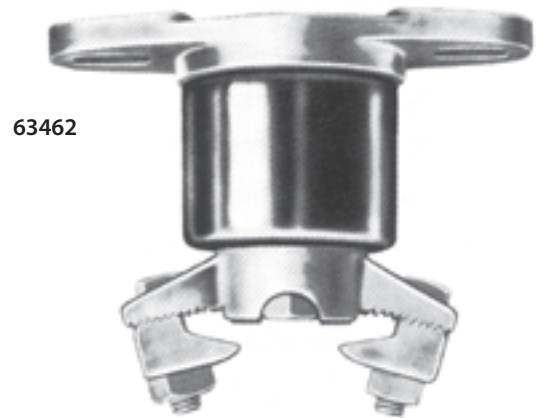

63462

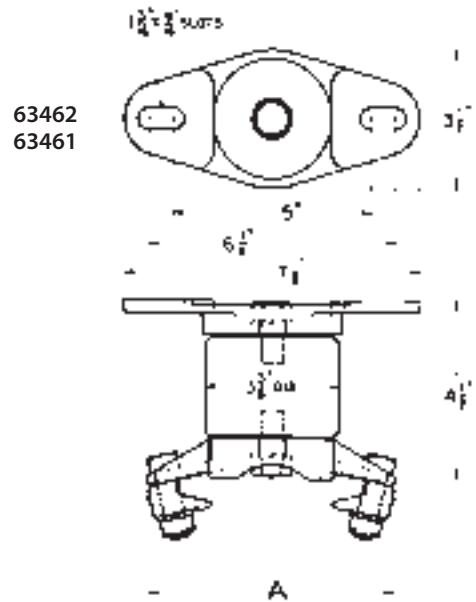

63462
63461

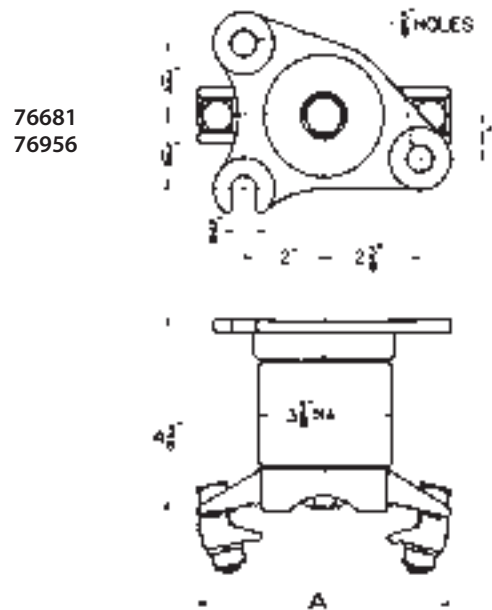

76681
76956

**Insulators Assemblies
Underrunning Conductors
Rail — Supports**

Application

Underrunning conductor rail supports for 750 volt service are used for every type of industrial crane operation.

Special mounting arrangements are available to meet specific problems.

Insulators are of high grade wet process porcelain finished in chocolate brown glaze.

Rail clamps are hot-dip galvanized.

Features

Good contact is assured because dirt, sleet or ice do not collect easily on contact surface of the rail.

Porcelain is in compression between the expanded mushroom head of rail supporting bolt and forged steel housing.

Insulating disk covers bolt head. Assembly is compound scaled against moisture insuring high dielectric values.

Formed steel washer acts as the bearing surface between bolt head and lead washer; bolt cannot pass through the housing hole even if porcelain should break away.

Weight is uniformly distributed by lead washers which cushion porcelain against abnormal strains. Notched rail grips interlocking with base clamp provide liberal adjustment and 1/2 inch adjustment up or down of the rail clamp, on the rail supporting bolt. Adjustment provides for variations in rail sizes and slight horizontal or vertical misalignment.

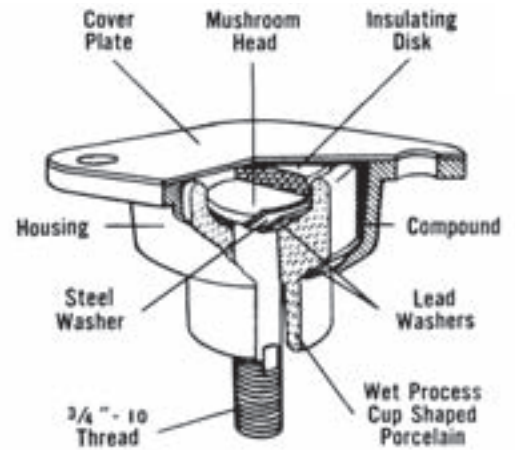
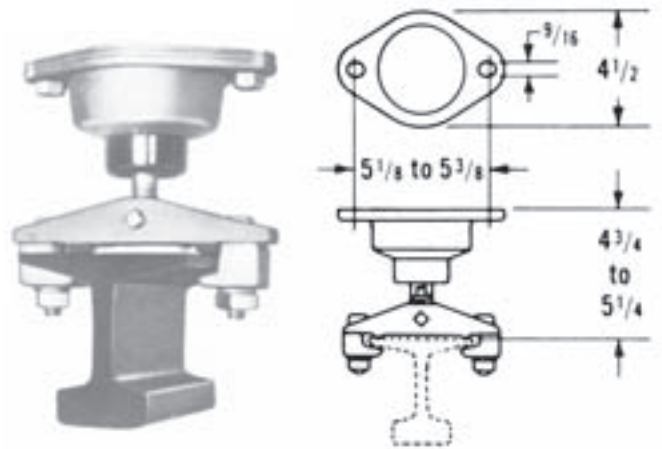

Catalog Information				
Rail Sizes — Pounds Per Yard			Net Wt. Each Lbs.	Catalog Number
A.S.C.E	A.R.A. Series A	A.R.A. Series A		
12 to 25	—	8 to 14	9	105212
—	—	16 to 30	9	105218
30 to 45	—	35 to 48	9.35	105213
50 to 70	60 to 70	—	9.8	105214
—	80	70 to 90	9.8	105216
75 to 100	90 to 100	—	10.3	105215
—	—	100	10.3	105217

Ordering Directions - Specify by Catalog Number.



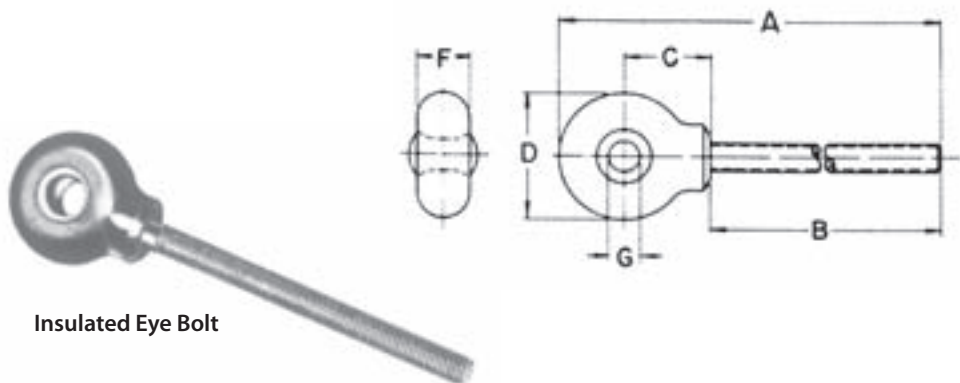

Insulated Eye Bolt



Drop-Forged Steel Eye Bolt

Eye Bolts

Application

Eye bolts are used for dead-ending and insulating trolley wire conductors are for any service requiring an insulator with provision for take up.

Features

Insulated eye bolts are made of formed steel rod, welded closed and zinc plated. Eyes are insulated with a thermo-set moulding compound and fitted with a brass bushing, having flared ends to protect the insulation and prevent damage to the strand or wire to which they are attached.

Drop forged steel eye bolts have extra long rolled threads and are equipped with square nut but without washers. Lengths are measured from under the eye. They are supplied galvanized.

Insulated Eye Bolts Catalog Information									
Bolt Dia. and Thread	A	B	C	E	F	G	Dry Flashover K.V.	Net Wt. Each Lbs.	Catalog Number
1/2" — 13 N.C.	11 ³ / ₁₆ "	8"	1 ¹³ / ₁₆ "	2 ³ / ₄ "	1 ¹ / ₈ "	1 ¹¹ / ₁₆ "	18	.94	48942
5/8" — 11 N.C.	10 ³ / ₁₆ "	7"	1 ¹³ / ₁₆ "	2 ³ / ₄ "	1 ¹ / ₈ "	1 ¹¹ / ₁₆ "	18	1.25	48946

Drop-Forged Steel Eye Bolts Catalog Information					
Length Inches	Dia. Inches	Length Thread Inches	Eye Opening	Net Wt. Each Lbs.	Catalog Number
6"	5/8"	4"	1 1/2" x 2"	1.16	31445
12"	5/8"	6"	1 1/2" x 2"	1.62	31449
16"	5/8"	6"	1 1/2" x 2"	1.87	31454

Ordering Directions - Specify by Catalog Number.

Turnbuckles

Application

Turnbuckles shown have numerous applications in industry for dead-ending trolley wire conductors and other similar uses.

Features

The #46280 insulated turnbuckle is a conventional drop forged steel turnbuckle equipped with a giant strain insulator with eye on one end providing an assembly with take-up for terminating trolley conductor wires.

This turnbuckle upon request can be provided with a clevis rather than an eye. Insulator eye is a malleable iron casting galvanized catalog #89149 which is listed separately. Non-insulated end is provided with a forged steel eye, galvanized.

When selecting a clevis to be used with these turnbuckles the strain type #90092 should be used so as to provide a large clevis opening.

The #31463 non-insulated galvanized turnbuckle is similar to the one above except with two forged steel eyes galvanized.



Catalog Information

Turnbuckle Description	Bolt Size	Size Opening	Eye Opening Approx.	Net Wt. Each Lbs.	Catalog Number
Insulated	5/8"	12"	(13/16" x 1" insulator end and 1 1/4" Dia.	4.40	46280
Non-Insulated	5/8"	12"	1 1/4" x 1 15/16"	3.55	31463

Trolley Terminal Clamp

Application

For dead-ending trolley wire conductors.

Features

The #31779 clamp can be used for terminating trolley wires of all shapes from 1/0 to 350,000 CM. Assembly consists of two malleable iron castings, galvanized providing a grooved opening to grip the wire. One section has three 5/8" diameter holes for attaching an insulator assembly in various positions. Clamp is 3/8" thick at this point. Four bolts used are steel galvanized.

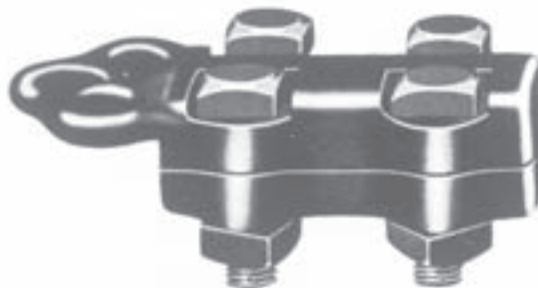

Catalog Information

Description	Net Wt. Each Lbs.	Catalog Number
Trolley Terminal Clamp	2.75	31779

Ordering Directions

Specify by Catalog Number.

Cable Strain Clamps

Application

Type P & PD clamps used in conjunction with the strain insulators shown on the preceding pages offer a simple and effective form of clamp for anchoring cables at right angle turns or dead ends.

When selecting strain insulators to be used with these clamps care should be exercised to select the insulator assembly with the proper size hardware to fit the clamp required, as shown below.

Features

Clamps consist of a heavy, well ribbed malleable iron galvanized casting, with one high strength bronze U-bolt in the type P series and two similar bolts in the type PD series which are used when greater strain loads are encountered.

Bolts draw the cable down on two or three projecting ribs provided in the casting for securely gripping the cable.

Castings have either "eye" or "clevis" connections.

These clamps having bronze U-bolts may be used on either AC or DC circuits.

Type P Cable Strain Clamps

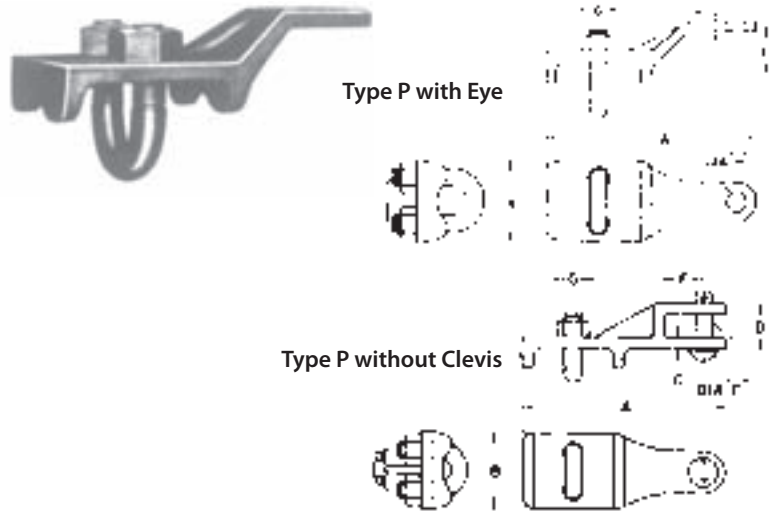

Type PD Cable Strain Clamps

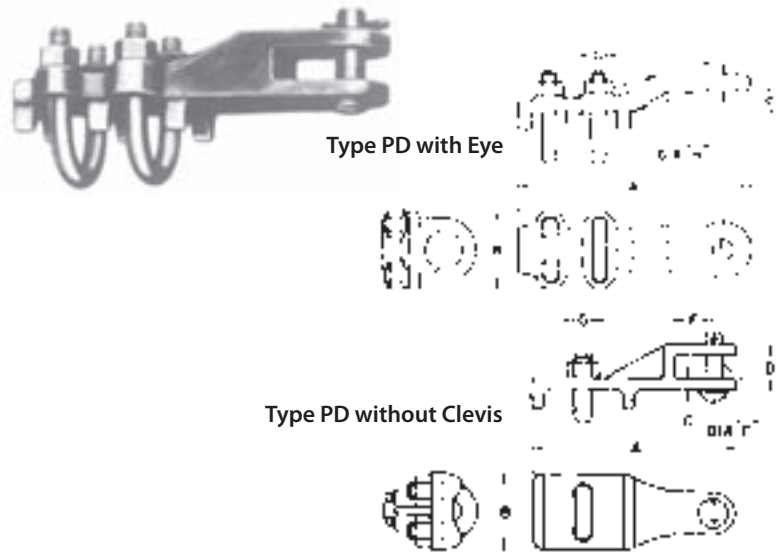

Type P Strain Clamps — Catalog Information

For Cables	Recommended Strain Insulator	Style Connection	Dimensions in Inches										Approx. Net. Weight Lbs.	Catalog No.	
			A	B	C	D	E	F	G	H	J				
2/0 B & S to 300 MCM	1/2" Series	Clevis	6"	2 ⁵ / ₁₆ "	1"	3/4"	1/2"	1 ¹ / ₈ "	1/2"	—	—	—	—	2.25	72785
2/0 B & S to 300 MCM	1/2" Series	Eye	6"	2 ⁵ / ₁₆ "	1 ¹ / ₄ "	—	—	—	1/2"	9/16"	5/16"	—	—	1.75	61314
300 to 600 MCM	5/8" Series	Eye	7 ¹ / ₂ "	2 ⁷ / ₈ "	1 ⁵ / ₈ "	—	—	—	5/8"	11/16"	3/8"	—	—	2.75	61315
600 to 1000 MCM	5/8" Series	Eye	8"	3 ¹ / ₄ "	1 ⁵ / ₈ "	—	—	—	3/4"	11/16"	3/8"	—	—	4.00	61316

Type PD Strain Clamps — Catalog Information

For Cables	Recommended Strain Insulator	Style Connection	Dimensions in Inches										Net. Weight Each Lbs.	Catalog No.	
			A	B	C	D	E	F	G	H	J				
350 to 700 MCM	5/8" Series	Clevis	8"	2 ¹ / ₂ "	7/8"	3/4"	5/8"	1 ¹ / ₂ "	1/2"	—	—	—	—	4.00	60945
350 to 700 MCM	5/8" Series	Eye	8 ¹ / ₄ "	2 ¹ / ₂ "	1 ³ / ₈ "	—	—	—	1/2"	3/4"	5/8"	—	—	3.50	64896
750 to 1250 MCM	5/8" Series	Clevis	8"	2 ¹³ / ₁₆ "	7/8"	3/4"	5/8"	1 ¹ / ₂ "	1/2"	—	—	—	—	4.50	60944
750 to 1250 MCM	5/8" Series	Eye	8 ¹ / ₄ "	2 ¹³ / ₁₆ "	1 ¹ / ₄ "	—	—	—	1/2"	3/4"	5/8"	—	—	4.00	62958

Screw Type Trolley Wire Clamps

Application

Trolley wire clamps are used for supporting trolley wires used as conductors for supplying current for the operation of electric cranes and industrial haulage systems. Grooved wire is preferable for use as conductors supported by clamp ears.

Features

Clamps are cast bronze, supplied in various lengths and machined to fit the particular type of wire for which they are designed. Clamps for grooved or figure 8 wire snugly fit the groove and therefore offer the minimum obstruction to the passage of the trolley wheel.

Clamps for round wire are made only in the sizes listed since this type wire is generally used for emergency or work of a temporary character.

National Bureau of Standards recommends the use of wire sizes not less than 1/10 B & S copper in all types of crane and hoist current collecting systems. All clamps have an overall height of 2" and are tapped 5/8" - 11 mounting.

Feeder clamps are the same general design except provided with a lug having a 3/8" diameter hole for feeder connections.

Special Instructions

In selecting insulators for use with these clamps be sure to check the clearance between the assembly of the insulator and clamp and the mounting surface.

Ordering Directions

Specify by Catalog Number.



Feeder Clamp



Standard Clamp

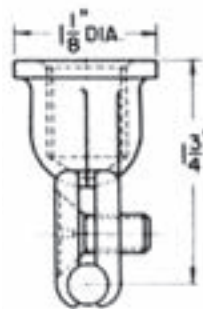

Round Wire

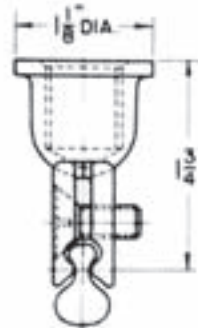
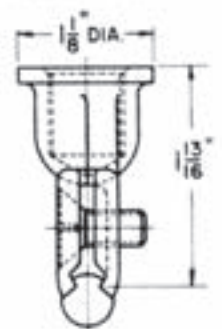

Figure B Wire



Grooved Wire

Catalog Information						
Capacity	Type Wire	Style	No. of Screws	Length	Net Wt. Each Lbs.	Catalog Number
#1 to #6 B & S and I/O	Round	Wire Clamp	3	3 ³ / ₈ "	.41	46634
1/0 to 2/0	Round	Wire Clamp	3	4 ⁷ / ₈ "	.50	41418
1/0 to 2/0	Round	Feeder	3	4 ⁷ / ₈ "	.55	48608
1/0 to 4/0	Figure 8	Wire Clamp	3	4 ⁷ / ₈ "	.70	31105
1/0 to 4/0	Figure 8	Feeder	4	7 ³ / ₈ "	1.25	31153
2/0 to 350 MCM	Grooved	Wire Clamp	3	4 ⁷ / ₈ "	.75	31098
2/0 to 350 MCM	Grooved	Wire Clamp	4	7"	.88	31108
2/0 to 350 MCM	Grooved	Feeder	4	7"	1.00	31151

**Mechanical Type
Splicing Sleeve**

Application

Mechanical splicing sleeves are designed for quick repair or joining of trolley conductor wire.

Features

Cast bronze splicing sleeve will fit all trolley wire shapes 2/0 to 4/0.

The wire centers the casting without forming to provide a smart transition.

Set screws and lock nuts are used to provide maximum power!



Capacity B25	Type of Wire	Length	Type Connection	Net Wt. Each - Lbs.	Catalog Number
2/0 to 4/0	All Types	11"	Set-Screw	1.33	46297

Inverted Angle Clamps Top Suspended

Application

Top supported inverted angle clamps support commercial angles, when used as power or control conductors, in the inverted V position. This arrangement provides protected contact surfaces and is therefore advantageous for exterior installations subject to adverse conditions of sleet and snow or contamination, or for interior use where abrasive dusts would subject conductor contacts to increased wear. Collector arrangements available for this configuration will provide for considerable misalignment.

The clamps permit expansion and contraction of the angle when used with proper brackets. Conductor clamps are listed to accommodate angle sizes from 2" x 2" to 4" x 4".

These units may be suspended from any of the insulators with $\frac{5}{8}$ " diameter integral or separate studs of adequate strength. In general, those insulators best suited for this application are the porcelain covered giant strain insulators or the molded insulators. Studs, where required, are available.

The swivel nut suspension member which is attached to the insulator stud, permits a certain amount of alignment correction, to provide for normal inaccuracies in supporting arrangements. Tolerances normal to commercial angles, are accommodated by the adjustable side members.

Side suspended inverted angle clamps are listed on the following page.

Features

Supporting clamps are made of malleable iron, hot galvanized, with swivel nut of bar steel, to provide great strength, and are supplied complete with bolts, nuts, and washers



46339
46340
46341

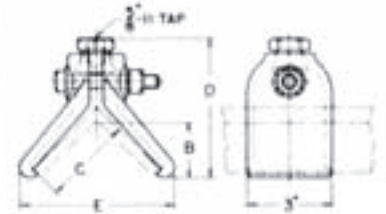

88749

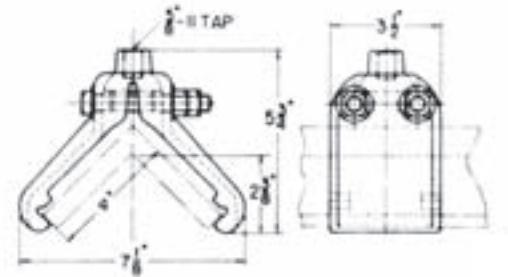

Catalog Information

For Angle Size (Inches)	Dimensions in Inches				Net Weight Each — Lbs.	Catalog Number
	B	C	D	E		
2 x 2	1 $\frac{1}{8}$	2	4 $\frac{3}{8}$	3 $\frac{5}{8}$	2.5	46339
2 $\frac{1}{2}$ x 2 $\frac{1}{2}$	1 $\frac{1}{2}$	2 $\frac{1}{2}$	4 $\frac{3}{4}$	4 $\frac{1}{2}$	3.4	46340
3 x 3	1 $\frac{7}{8}$	3	5	5 $\frac{1}{4}$	3.5	46341
3 $\frac{1}{2}$ x 3 $\frac{1}{2}$	2 $\frac{3}{16}$	3 $\frac{1}{2}$	5 $\frac{3}{8}$	5 $\frac{3}{4}$	3.9	63388
4 x 4	Shown in Diagram				6.3	88749

Inverted Angle Clamps Side Suspended

Application

Side supported inverted angle clamps support commercial angles, when used as power or control conductors, in the inverted V position. This arrangement provides protected contact surfaces and is therefore advantageous for exterior installations subject to adverse conditions of sleet and snow or contamination, or for interior use where abrasive dusts would subject conductor or contacts to increased wear. Side mounting of the insulator permits closer vertical stacking of conductors, but ordinarily is not used where severe conditions of horizontal misalignment occur. Collectors used with side suspended inverted angle systems are available.

The clamps permit expansion and contraction of the angle conductors when used with proper brackets. Clamps are listed to accommodate 2" x 2", 2 1/2" x 2 1/2" and 3" x 3" angles.

Insulators of proper configuration and superior cantilever strength, for this service may be selected from the porcelain covered giant strain units or the molded insulators.

Tolerances normal to commercial angles, are accommodated by the adjustable side members. Top suspended inverted angle clamps are listed on the preceding page.

Features

Supporting clamps are made of malleable iron, hot galvanized, and are supplied with bolts, nuts, and washers.

Ordering Directions

Specify by Catalog Number.

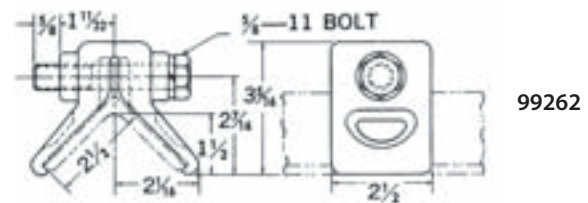
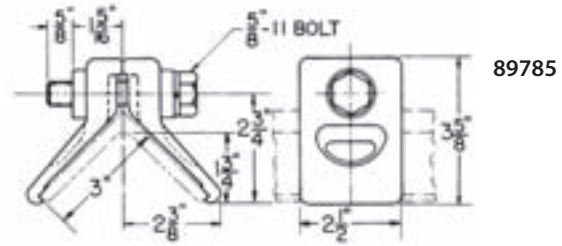
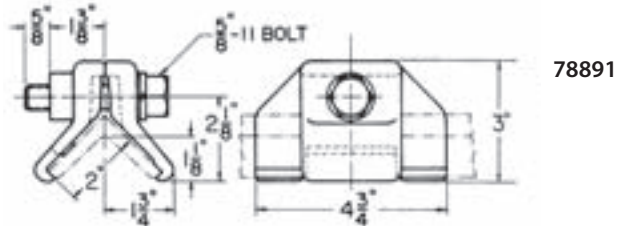

Catalog Information

For Angle Size (Inches)	Suitable Insulators	Size Cap Screw	Net Weight Each — Lbs.	Catalog Number
2 x 2	Any 5/8" - 11 Thread Insulator See Insulators Catalog	5/8	3.0	78891
2 1/2 x 2 1/2		5/8	3.0	99262
3 x 3		5/8	3.1	89785

Terminals — Weld Feeder

Application

Standard weld type connectors are used as terminals for feeder cables or for supporting supplementary feeder copper cables carried parallel to the rail. They may also be used as bond terminals. They are used with T Rails or other rigid conductors in contact rail systems.

Features

Standard two-piece cast bronze connectors equipped with bolts of the sizes as shown in the listing, are brazed or silver-soldered to a formed steel plate as shown on the illustration. This construction assures high conductivity and mechanical strength despite the welding temperatures involved when the steel tongue is welded in place. The tongue can be readily bent on the job, if desirable.

Connectors of types listed on this page constitute a standardized line for attachment to a T rail or any other conductor, making one general type of connector suitable for either overrunning or underrunning contact. Base plates are so designed that with proper welding the capacity will in all cases exceed that of the cable capacities for which they are designed. Rail sizes shown are based upon attachment to the web of the rail as shown.

Ordering Directions

Specify by Catalog Number.

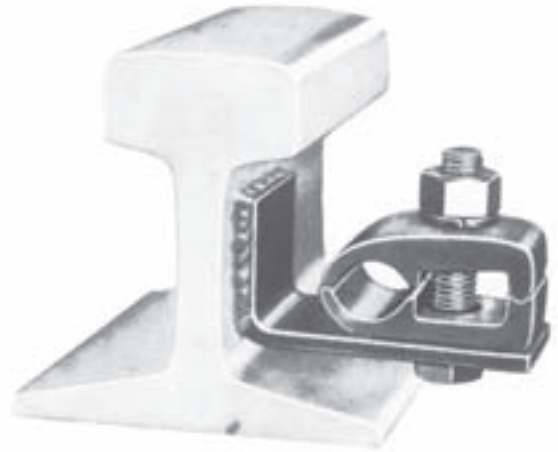

View of weld mounted terminal on rail

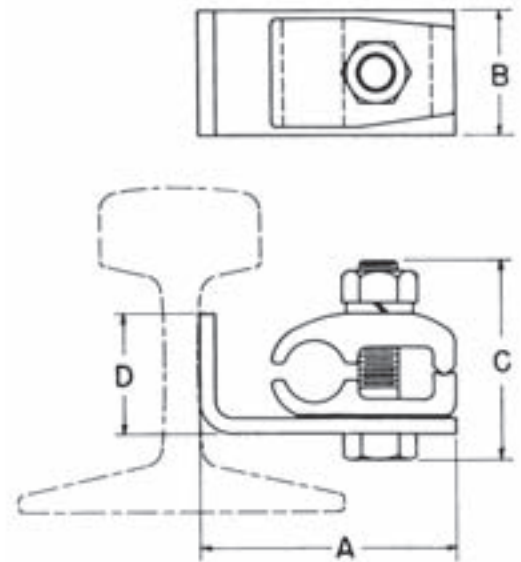

Catalog Information									
Cable Range		Min. Rail Size A.S.C.E. Lbs. Per Yard	Dimension (Inches)				Bolt Dia.	Approx. Wt. Each Lbs.	Catalog Number
Minimum	Maximum		A	B	C	D			
4 B & S	2/ B & S	16	2 ³ / ₄	1 ¹ / ₂	1 ³ / ₄	1 ¹ / ₄	³ / ₈	.6	76020
2/0 B & S	250 M.C.M.	30	3 ¹ / ₄	1 ³ / ₄	2	1 ¹ / ₂	¹ / ₂	1.0	76021
300 M.C.M.	500 M.C.M.	40	3 ¹ / ₂	2	2 ¹ / ₂	1 ³ / ₄	¹ / ₂	1.5	76022
500 M.C.M.	750 M.C.M.	55	4	2 ¹ / ₄	3	2	⁵ / ₈	2.5	76023
750 M.C.M.	1000 M.C.M.	65	4 ¹ / ₂	2 ¹ / ₂	3 ¹ / ₈	2 ¹ / ₄	⁵ / ₈	3.6	76024

Strain Eyes & Strain Clevises

Application

Hardware listed is for use with TransTech insulators to provide assemblies for the various applications described and illustrated.

Features

Strain eyes, strain clevises and the four styles of support clevises are malleable iron castings, galvanized. Castings are tapped as shown in the drawings with either 1/2"-13 or 5/8"-11, NC-2 threads. Depth of the tap is equal to or greater than the diameter.

Ordering Directions

Specify by Catalog Number.

Strain Eyes

Application

Used with strain insulators for supporting cable, etc. Large eye opening with generous radii prevents damage to wire.

Catalog Information		
Description	Net Wt. Each — Lbs.	Catalog Number
1/2" Strain Eye	.25	93194
5/8" Strain Eye	.47	89149
3/4" Strain Eye	.69	89150

Strain Eyes

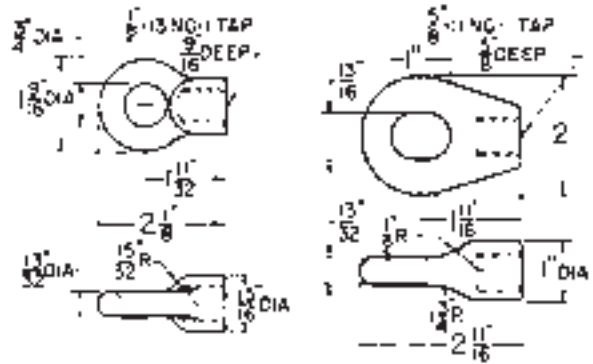

Strain Clevises

Application

Used on strain insulators with cable strain clamps for supporting cables, etc.

Catalog Information		
Description	Net Wt. Each — Lbs.	Catalog Number
1/2" Strain Clevis	.25	63449
5/8" Strain Clevis	.70	90092

Strain Clevises

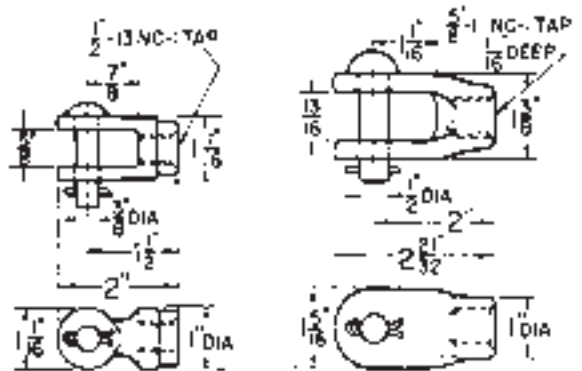

Support Clevises and Bar Support Bracket

Support Clevises

Application

Used with insulators for supporting tees, angles or bars or for attaching insulators to supporting structures.

These clevises have different slot openings and are provided with either clevis pins, set screws or bolts for attaching the conductors.

Catalog Information		
Description	Net Wt. Lbs. — Each	Catalog Number
1/2" Clevis with pin	.55	90809
1/2" Clevis with set screw	.35	93905
1/2" Clevis with bolt	.56	98311
1/2" Clevis with bolt	.53	98313
5/8" Clevis with pin	.50	63446
5/8" Clevis with set screw	.35	48777
5/8" Clevis with bolt	.55	98312
5/8" Clevis with bolt	.52	98314

Ordering Directions

Specify by Catalog Number.

Bar Support Bracket

Application

Bar support brackets are used to mount flat bar, angles and tees for use as overrunning conductors. They are designed to accommodate bar thicknesses from 1/4" to 3/4", and widths from 1" to 1 1/2". Angles and tees up to 1 1/2" may also be used with these units. Set screws clamp the conductor bar tightly, eliminating the need for drilling of conductor for support purposes. This method is satisfactory for crane cross travel conductors or main runway conductors in which expansion and contraction will not over-stress insulators.

Catalog Information		
Description	Net Wt. Lbs. — Each	Catalog Number
1/2" Clevis with pin	.55	90809
5/8" Clevis with bolt	.52	98314

Ordering Directions

Specify by Catalog Number.

Support Clevises

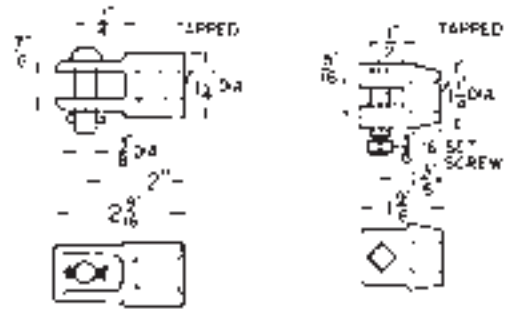

90809 — 1/2" Pin Type
63446 — 5/8" Pin Type

93905 — 1/2" Set Screw Type
48777 — 5/8" Set Screw Type

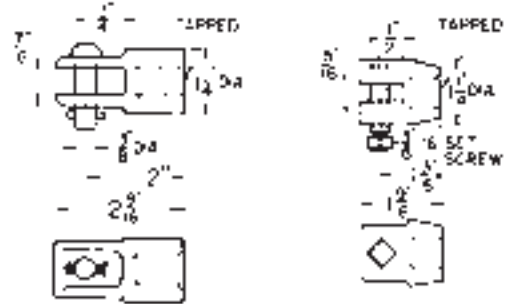

90811 — 1/2" Bolt Type
98312 — 5/8" Bolt Type

98313 — 1/2" Bolt Type
98314 — 5/8" Bolt Type

Bar Support Bracket

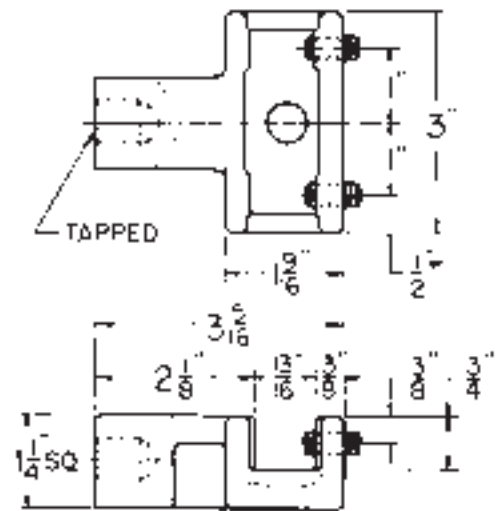

Expansion Stud Fittings

Application

Expansion stud fittings are for use in supporting angles, tees or bar conductors where expansion and contraction of conductor must be accommodated. Properly applied, these units will prevent insulator damage due to overstress from conductor movement.

In Figure 1, dimension "X" represents the distance between the means of support and the center of the angle bar contact rail and may be determined by the letter references showing width of insulators and fittings used in making up the assembly.

It is important proper clearance of at least $\frac{3}{8}$ " be provided between the insulator and contact surface to avoid interference with collectors.

TransTech red-poly insulators are especially adapted to this type installation due to the wide selection of heights offered.

Features

Expansion stud fittings are provided with shoulder to prevent tight clamping of conductor. Conductor is slotted with elongated holes allowing free movement for expansion. See illustration for mounting arrangement.

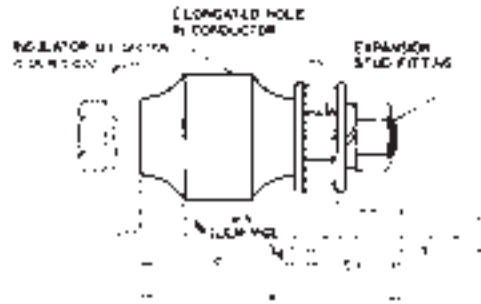

Typical method of supporting under-running angle conductor with the expansion stud fitting.

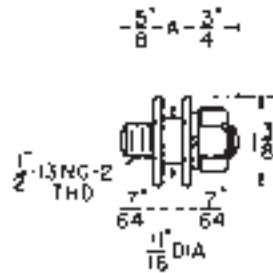

1/2" stud assembly

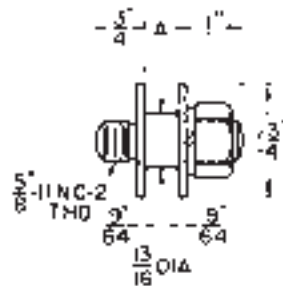

5/8" stud assembly

Catalog Information			
Description	Dimension* A	Net Wt. Each — Lbs.	Catalog Number
1/2" Exp. Stud	5/16"	.22	76636
5/8" Exp. Stud	5/16"	.44	74673
5/8" Exp. Stud	3/8"	.44	72825
5/8" Exp. Stud	7/16"	.44	74274
5/8" Exp. Stud	1/2"	.44	63651
* Represents thickness of the conductor bar plus 1/16"			

Ordering Directions

Specify catalog number and "Dimension A."

Spacing Washers

Application

Spacing washers are sometimes required to provide added clearance for collectors between the mounting surface and conductors. They are made of cast iron, galvanized, and are normally inserted between the mounting structure and the insulator.

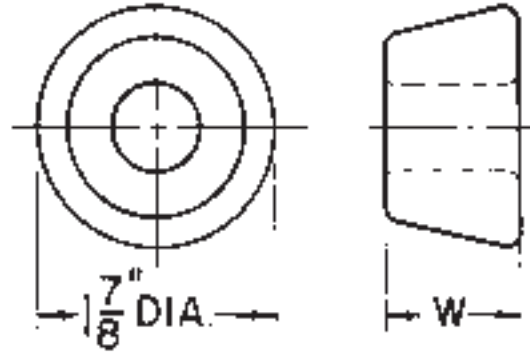

Catalog Information			
Description	W Dia.	Net Wt. Each	Catalog Number
1/2" Spacing Washer	5/16"	.66	77795
5/8" Spacing Washer	5/16"	.31	65676
5/8" Spacing Washer	3/8"	.53	65677

Miscellaneous Hardware Threaded Studs, Steel-Zinc Plated (Other lengths available upon request)	
Dimensions	Catalog Number
1/2" • 13 x 1 1/2" long	75525
1/2" • 13 x 3 1/4" long	90668
1/2" • 13 x 6 1/2" long	76081
5/8" • 11 x 1 7/16" long	94635
5/8" • 11 x 3 5/16" long	90669
5/8" • 11 x 7 3/4" long	76270

Hexagon Head Cap Screws Steel Galvanized (Other lengths available upon request)	
Dimensions	Catalog Number
1/2" • 13 x 1" long	59687
1/2" • 13 x 2" long	77818
1/2" • 13 x 2 1/2" long	72839
5/8" • 11 x 7/8" long	74860
5/8" • 11 x 1" long	70757
5/8" • 11 x 1 1/4" long	70750
5/8" • 11 x 1 1/2" long	70754
5/8" • 11 x 1 3/4" long	70755
5/8" • 11 x 2" long	65680
5/8" • 11 x 2 1/2" long	65681
3/4" • 10 x 1 1/8" long	71409
3/4" • 10 x 1 1/4" long	72939
1" • 8 x 1 3/8" long	74427

Square Nuts Steel-Zinc Plated	
Dimensions	Catalog Number
Nut 1/2" • 13	94717
Nut 5/8" • 11	94718

Flat Washers Steel Galvanized	
Dimensions	Catalog Number
Flat Washer 1/2"	28809
Flat Washer 5/8"	29475

Split Lock Washers Galvanized	
Dimensions	Catalog Number
Lock Washers 1/2"	59711
Lock Washers 5/8"	59712
Lock Washers 3/4"	71940

Shakeproof Lock Washers External Tooth-Zinc Plated	
Dimensions	Catalog Number
Lockwashers 5/8"	75433
Lockwashers 3/4"	58124
Lockwashers 1"	74430

Ordering Directions

Specify catalog number and "Dimension A."

Collectors - Pick-Up Type XVI

Application

XVI Collectors are for pick-up wire conductor systems, mainly used on overhead crane bridges to collect current from the trolley wire conductor system to run the transverse movement or lifting motors of the crane. These collectors are suitable for all sizes of trolley wire up to and including 3/0 B & S.

Features

The XVI Collector consists of an aluminum or brass body made in two halves which retains the contact member. This type of collector provides a self-cleaning and lubricating action which maintains a burnished conductor wire assuring longer life.

On critical circuits to assure continuity of service or where dirt contamination is prevalent, collectors in tandem are recommended. When using the square bar mounting, a single bracket assembly supports two collectors in tandem, however when using collectors with insulator mounting for the same purpose, two collectors are mounted together to suit the customer's mounting conditions.

Special Features

Body - Two types

- Aluminum -recommended for indoor service.
- Brass -recommended for outdoor service or where excessive industrial contamination prevails.

Terminal mounting holes are provided as shown on drawings.

Mounting - Two types

- Composition insulator with integrated molded shaft and tapped boss.
- Bracket for square bar mounting. In this type the insulation is provided by the customer's mounting which normally consists of a square bar covered with an insulating tube. Brackets are designed for mounting on square bars including insulation from 1" to 1 1/2". It is necessary when ordering to specify the size bar used including the insulation.

Removable Contact Members

Accurately machined grooved blocks to secure maximum transfer of current. They can easily be replaced by loosening two screws in the body assembly. Furnished in two capacities.

- Standard (Electro Graphite Carbon) - 35 to 75 amperes approximate continuous rating depending upon working conditions.
- High Capacity (Metal Graphite) - 75 to 125 amperes approximate continuous rating depending upon working conditions.

Collector Unit with Threaded Stud

This unit is supplied for replacement or where user supplies the insulator. For this application the collector unit is equipped with a special shaft threaded 1/2" - 13 and supplied with a jam nut.

COLLECTORS



XVI Collector with Insulator Mounting showing the contact member partly removed

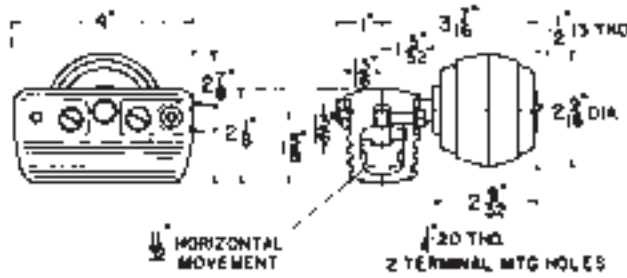

Single XVI with Insulator Mounting



XVI Collector Unit with Threaded Stud



Tandem Type XVI Collector for Square Bar Mounting

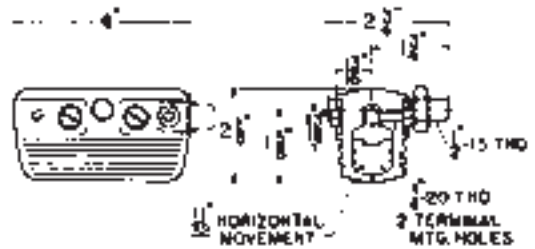

Collector Unit only with Threaded Stud

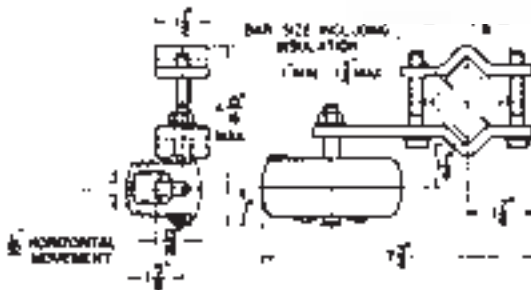

Single XVI with Square Bar Mounting

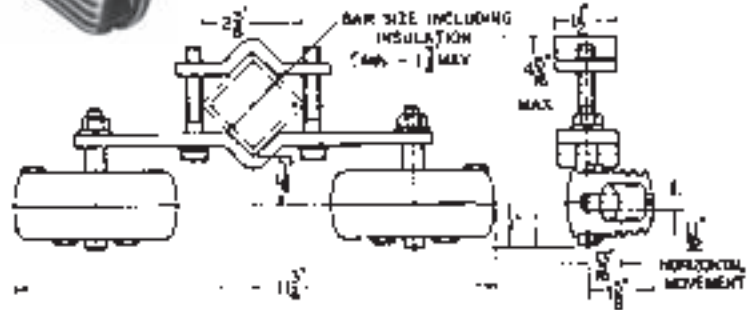

Double XVI with Square Bar Mounting

Catalog Information

Style of Mounting	Collector	Body	Contact	Contact Number	*Approx. Continuous Current Capacity Amperes	Net Wt. Each Lbs.	Catalog Number
Insulator	Single	Alum.	Standard	88321	35 - 75	1.50	88804
Insulator	Single	Alum.	High Capacity	88597	75 - 125	1.80	88595
Insulator	Single	Brass	Standard	88321	35 - 75	2.75	88825
Insulator	Single	Brass	High Capacity	88597	75 - 125	3.05	91554
Square Bar	Single	Alum.	Standard	88321	35 - 75	2.45	93828
Square Bar	Double	Alum.	Standard	88321	70 - 150	3.70	93382
Square Bar	Single	Alum.	High Capacity	88597	75 - 125	2.75	93829
Square Bar	Double	Alum.	High Capacity	88597	150 - 250	4.40	93830
Square Bar	Single	Brass	Standard	88321	35 - 75	3.75	98390
Square Bar	Double	Brass	Standard	88321	70 - 150	6.35	98367
Square Bar	Single	Brass	High Capacity	88597	75 - 125	4.05	98391
Square Bar	Double	Brass	High Capacity	88597	150 - 250	7.00	98368
1/2" Threaded Stud	Single	Alum.	Standard	88321	35 - 75	1.0	88803
1/2" Threaded Stud	Single	Alum.	High Capacity	88597	75 - 125	1.3	88596
1/2" Threaded Stud	Single	Brass	Standard	88321	35 - 75	2.25	90428
1/2" Threaded Stud	Single	Brass	High Capacity	88597	75 - 125	2.55	92422
Standard Renewable contact only						.13	88321
High Capacity Renewable contact only						.44	88597

* This rating is necessarily approximate due to changes in working conditions
 Ordering Directions: Specify by catalog number.
 On bar mounted collectors, specify bar size when ordering, from 1" to 1 3/4" including insulation.

Collectors - Pick-Up
Type XVE, BV, BW, PW

Application

Four types of "Pick-up" collectors illustrated are mainly used on overhead crane bridges to collect current from the trolley conductor system to run the transverse movement or lifting motors of the crane.

The XVE collectors are "pick-up" wire conductor systems where the runs are comparatively short and current requirements are low.

These collectors are suitable for all sizes up to and including #3/0 B & S trolley conductors.

Features

Contact members of the type XVE is a grooved carbon insert bonded to a copper plated steel body and can be quickly removed and replaced by means of a cotter pin. Terminal connections can be made to the holes on either side of the body. Short height of this unit permits close spacing of the trolley wire conductors.

BV, BW, and PW contact members are either bronze wheels or shoes, the sliding shoe type of contact being preferred where there is dust and dirt because of its self-cleaning action.

Types BV and BW have a molded composition insulator with an integrally molded shaft while the PW is furnished with a porcelain corrugated insulator.

Type BW is constructed with two contact wheels mounted on a frame to provide a higher capacity positive contact with the conductor wire. Its compactness permits close spacing of conductors.

Type PW with porcelain corrugated insulator provides better insulation, particularly for outdoor service.

Type BV has sliding contact providing self-cleaning action. It is compact, permitting close spacing of conductors.

Type XVE collector consists of insulator with an integrally molded shaft supporting an inexpensive replaceable contact.

Type XVE

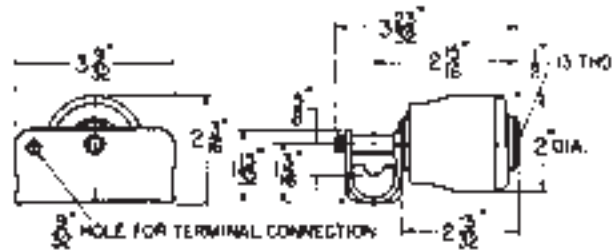
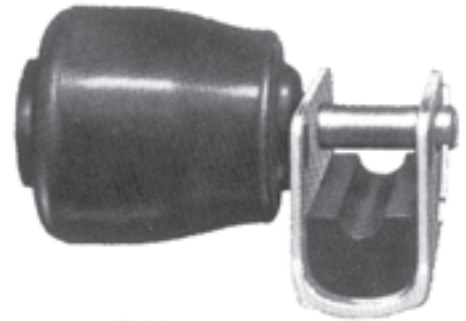

Type XVE collector consists of insulator with an integrally molded shaft supporting an inexpensive replaceable contact.

Type BW

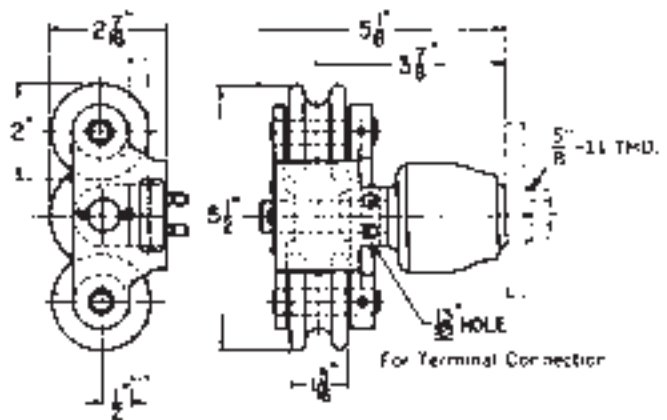
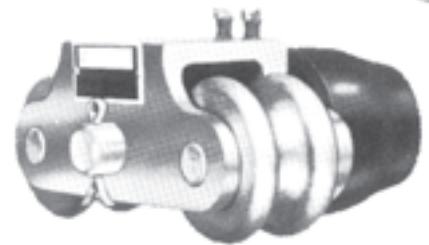

Type BW with two contact wheels mounted on a frame to provide a higher capacity and positive contact with the conductor wire. Its compactness permits close spacing of conductors.

**Collectors - Pick-Up
Type XVE, BV, BW, PW**

Type BV

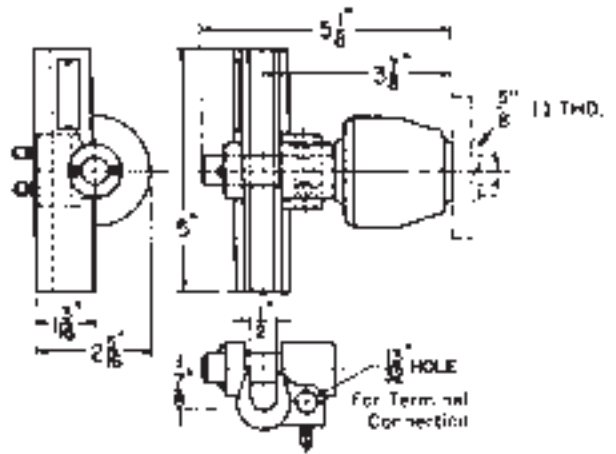
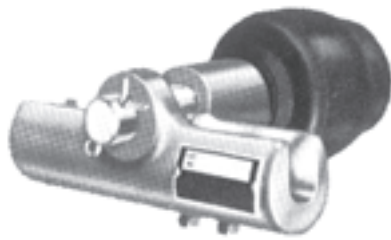

Type BV with sliding contact provides self-cleaning action, its compactness permits close spacing of conductors.

Type PW

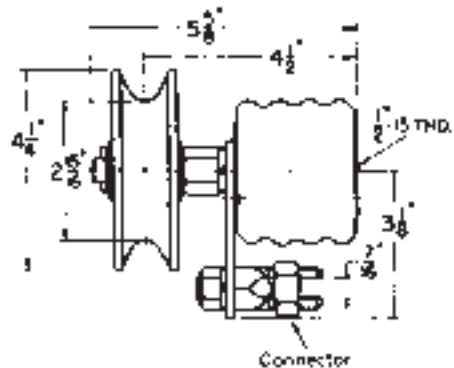
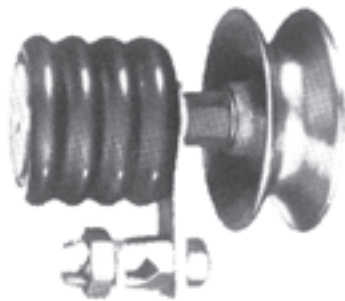

Range up to 3 0 Solid and 2 0 Standard Max

Type PW with porcelain corrugated insulator provides better insulation, particularly for outdoor service.

Catalog Information

Description	Contact Number	*Approx. Current Capacity Amperes	Net Wt. Each Lbs.	Catalog Number
XVE Complete	93824	35	.90	93820
Replaceable Contact	---	35	.45	93824
BV Collector Complete	46615	100	3	46491
BW Collector Complete	46488	75	4.75	46492
PW Collector Complete	18897	75	5	70545

*This rating is approximate due to changes in working conditions.

Ordering Directions

Specify by catalog number.

**Collectors - Arm Type
"Junior" Series**

Application

"Junior" series of wire or rigid type conductor collectors illustrated are designed for light crane indoor operation with service characteristics as listed. This is the "Junior" series of a group of collectors including the "Universal" and "Pantograph" type for wire or rigid conductor applications.

Features

"Junior" collectors consist of a malleable iron arm and mounting assembly with either bronze wheels or shoes as contact members. Compression spring in the mounting assembly maintains pressure for contact with the conductor.

Arm can swivel 360° so that the collector can be positioned to meet space and mounting conditions. This is also of value in allowing for some misalignment of the conductor.

Insulation is provided by either a giant strain insulator or a square mica tube bushing depending upon the type of mounting.

Provision for feeder connections are provided direct to the contact shoe or to the mounting body in the wheel types.

Installation of collectors in parallel on the same conductor is recommended in order to assure maximum efficiency and insure continuous contact. This is particularly desirable on control circuits or in contaminated areas where dirt build-up reduces contact efficiency.



60036
Collector with grooved wheel and giant strain insulator mounting

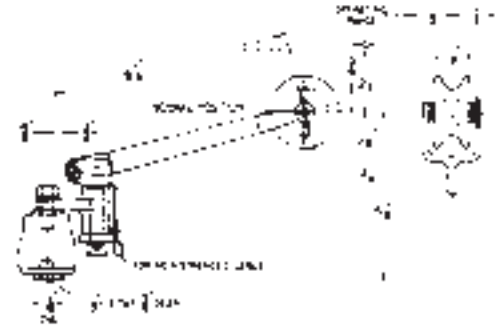

60141
Collector with grooved wheel and insulated square bar mounting

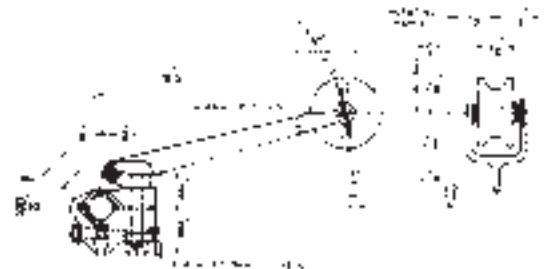

**Collectors - Arm Type
"Junior" Series**

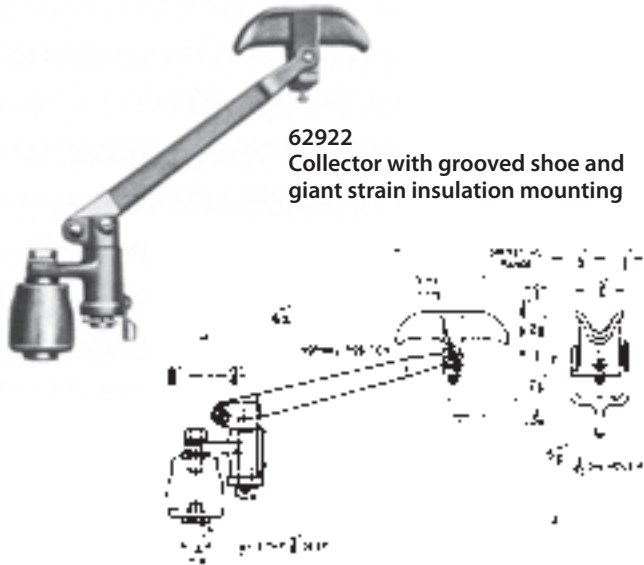

62922
Collector with grooved shoe and
giant strain insulation mounting

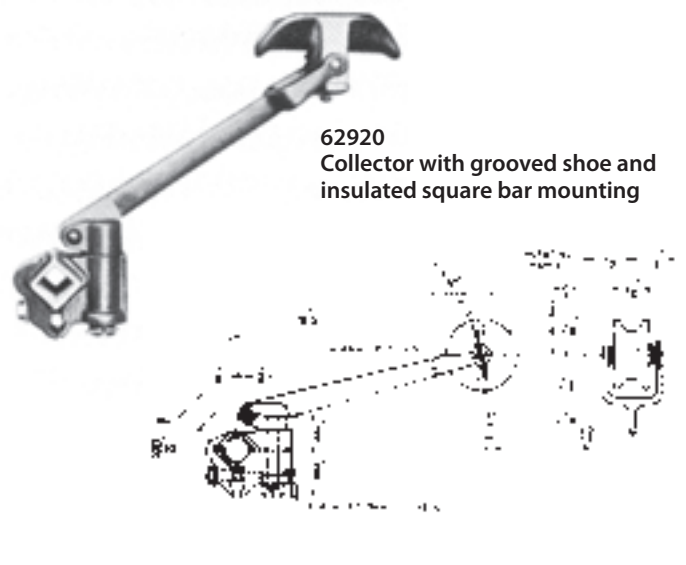

62920
Collector with grooved shoe and
insulated square bar mounting

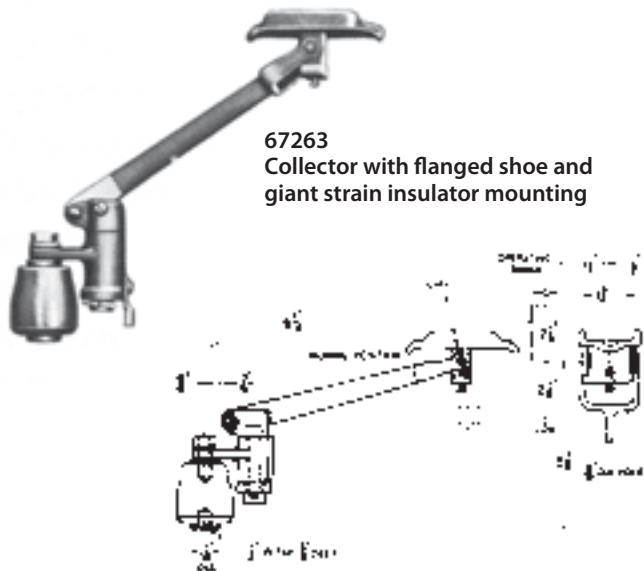

67263
Collector with flanged shoe and
giant strain insulator mounting

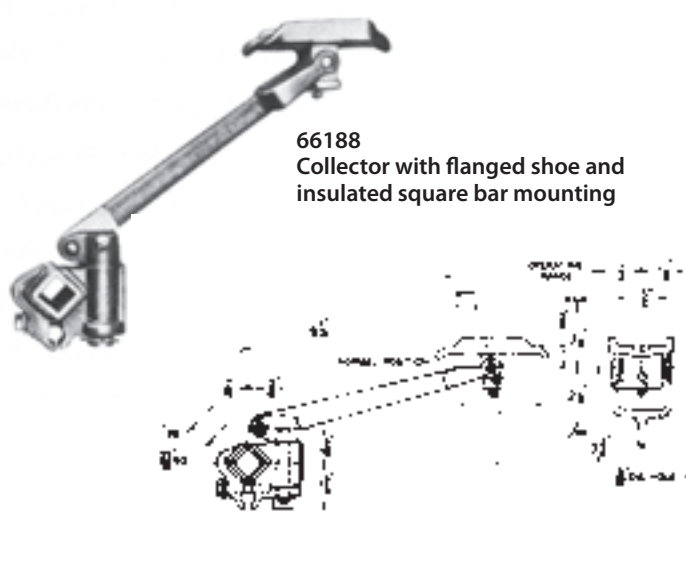

66188
Collector with flanged shoe and
insulated square bar mounting

Catalog Information

Description	Type of Mounting	Contact Member	*Approx. Current Capacity Amperes	Maximum Service Rating Volts	Net Wt. Each Lbs.	Catalog Number
Type JAW	Insulator	60047 — 2 1/2" Bronze Wheel	40	750	3.50	60036
Type JBW	Square Bar	60047 — 2 1/2" Bronze Wheel	40	750	3.50	60141
Type JAS	Insulator	62918 — Bronze Shoe	75	440	3.50	62922
Type JBS	Square Bar	62918 — Bronze Shoe	75	440	3.50	62920
Type JAF	Insulator	62918 — Bronze Shoe	75	750	3.50	67263
Type JBF	Square Bar	62918 — Bronze Shoe	75	440	3.25	66188

* Current carrying capacities are approximate as they depend upon conditions of installation such as speed, contact pressures, frequency of use, cleanliness of contact surfaces, etc.

Ordering Directions - Specify by catalog number.

Collectors - Arm Type "Universal Series"

Application

"Universal" collectors are used for many conductor systems as required on crane bridge or main runways or similar applications. Designation "Universal" refers to the design which, by combining parts, provides mountings and contacts to meet varying conditions. Collectors shown are considered as standard, however other assemblies are available, made to order, such as collectors with porcelain insulators, bronze contacts, other width contacts, without insulators, etc.

Features

Collector consists of cast iron and aluminum arm assembly with mounting and various shapes of shoes or wheels as contact members. Strong adjustable compression spring maintains the proper pressure of the contact member with the conductor depending upon operating conditions.

Feeder connections are made to the contact member of the shoe types or to the arm of wheel types. Horizontally mounted collectors shown have swivel bases to compensate for a certain degree of misalignment of the conductor wire. Vertically mounted collectors have a rigid base but the wheel has an extending shaft for side movement in case of misalignment.

Two Red-Poly insulators are normally supplied for mounting, however where excessive moisture or industrial contamination are prevalent, porcelain insulators can be supplied with a larger mounting base, made to order.

Dual installation of collectors connected in parallel on the

same conductor is recommended in order to assure maximum efficiency and insure continuous contact. This is particularly desirable on control circuits or in contaminated areas where dirt build-up reduces contact efficiency.

Collectors having flat shoe contacts with or without flanges have a cleaning groove to allow dirt contamination to drop away and are furnished with two special composition inserts achieving a lubricating and burnishing action on the conductor.

Catalog No's 46199 and 46211 collectors are supplied with high quality bronze wheels and are normally used on systems of low current ratings.

Catalog No. 93148 collectors have a grooved bronze sliding contact furnishing a self-cleaning action together with a greater contact surface.

Catalog No's 92944 and 94136 have a grooved bronze sliding contact with two special composition inserts achieving a lubricating and burnishing action on the conductor wire. Inserts are furnished in two ratings, the "Standard" and the "High Capacity" with values as shown in the tabular listing on the following page.

Catalog No's 94058 and 94059 collectors have a cast iron arm provided with a ball that fits a socket in the shoe thus providing considerable movement or shoe in case of conductor misalignment. The long cast iron shoe has a large cleaning groove. This shoe provides two contact surfaces, fitting the inside of an inverted angle conductor.

Catalog No. 46227 collector is provided with a bronze flanged wheel for use on a narrow tee or bar conductors.



Typical arrangement of collectors in parallel

Collectors - Arm Type
"Universal Series"



46199

Collector with horizontal mounting and bronze wheel contact.



46211

Collector with vertical mounting and bronze wheel contact.



93148

Collector with horizontal mounting and bronze sliding contact.



92944 or 94136

Collector with horizontal mounting and sliding contact with standard or high capacity inserts.



94106

Collector with horizontal mounting and cast iron grooved contact shoe with inserts.

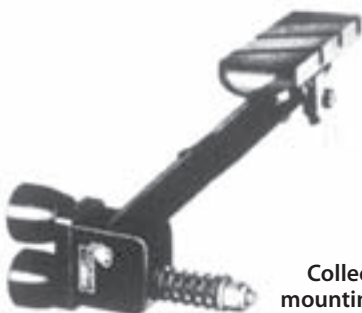

46192

Collector with vertical mounting and cast iron flat contact shoe with inserts.



94058

Collector with horizontal mounting and inverted "V" cast iron shoe for inverted angles used as conductors.

**Collectors - Arm Type
"Universal Series"**

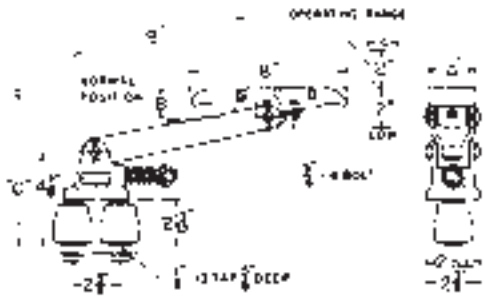

	A	B	C
92868 with 1 1/4" wide shoe	1 1/4	1 3/14	9 3/16
94060 with 2 1/3" wide shoe	2 1/2	1 1/2	9 3/8



	A	B	C
94102 with 1 1/4" wide shoe	1 1/4	1 3/14	4 3/16
94103 with 2 1/3" wide shoe	2 1/2	1 1/2	4 3/8

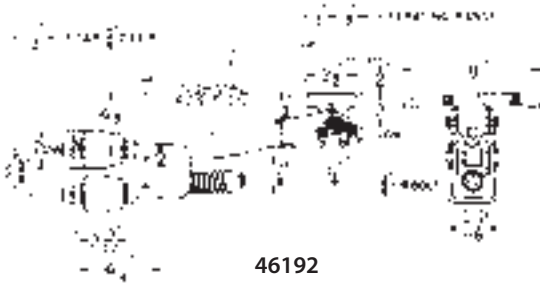

46192



46227

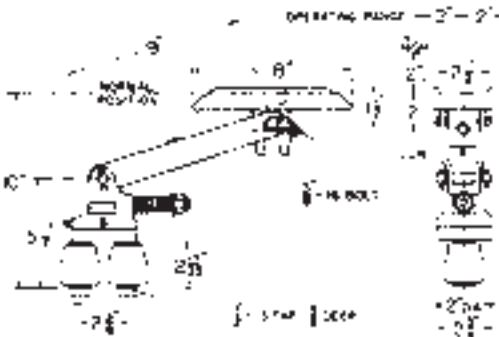

94106

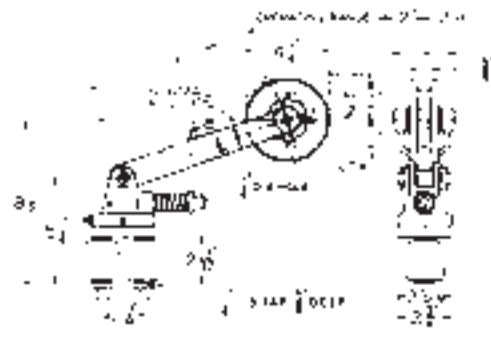

46199

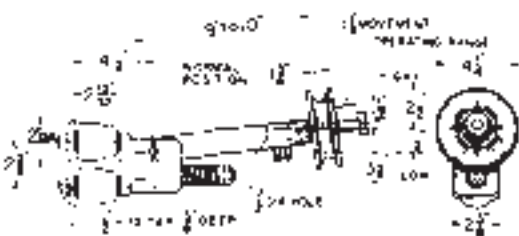

46211



93148

Collectors - Arm Type
"Universal Series"

92944
94136

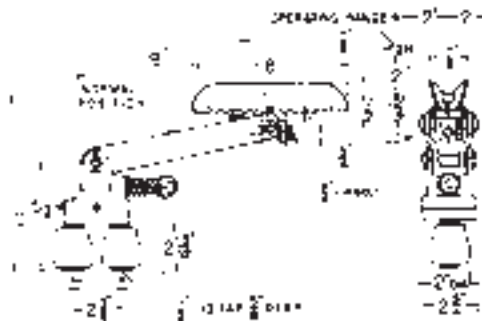

94058

Used with 2" and 2 1/2" Angles.



94059

Used with 3" and 4" Angles.

Catalog Information

Description	Width of Contact Inches	Contact Number	Distance from Mounting Surface to Conductor Inches	*Approx. Current Capacity Amperes	Maximum Service Rating Volts	Net Wt. Each Lbs.	Catalog Number
Collector - Horizontal Mounting Bronze Wheel		18897	10	75	750	11	46199
Collector - Vertical Mounting Bronze Wheel		18897	See Drawing on page 9	75	750	9 1/2	46211
Collector - Horizontal Mounting Bronze Sliding Contact		94657	9 3/8	150	750	11 1/4	93148
Collector - Horizontal Mounting Sliding Contact & Standard Inserts		94658	10	150	750	11	92944
Collector - Horizontal Mounting Sliding Contact & High Capacity Inserts		94661	10	200	750	11 1/2	94136
Collector - Horizontal Mounting Flat Iron Shoe with Inserts	1 1/4	94770	9 3/16	75	750	9	92868
Collector - Horizontal Mounting Flat Iron Shoe with Inserts	2 1/2	94654	9 3/8	125	750	11	94060
Collector - Vertical Mounting Flat Iron Shoe with Inserts	1 1/4	94770	See Drawing on page 9	75	750	10 1/2	94102
Collector - Vertical Mounting Flat Iron Shoe with Inserts	2 1/2	94654	See Drawing on page 9	125	750	11 1/2	94103
Collector - Vertical Mounting Flat Shoe with Inserts	2 1/2	93121	See Drawing on page 9	125	750	11 1/2	46192
Collector - Horizontal Mounting Flanged Bronze Wheel	1 1/8	46162	10	100	750	11 1/4	46227
Collector - Horizontal Mounting Flanged Iron Shoe with Inserts	2 1/2	94660	10	125	750	13	94106
Collector - Horizontal Mounting Inverted V Shoe - Ball & Socket Design		94659	See Drawing Above	150	750	12 1/2	94058
Collector - Horizontal Mounting Inverted V Shoe - Ball & Socket Design		94094	See Drawing Above	150	750	15 3/4	94059

*Current carrying capacities are approximate as they depend upon conditions of installation such as speed, contact pressure, frequency of use, cleanliness of surfaces, etc.

Collectors - Pantograph Wire Conductor Series

Application

Pantograph Collectors with wheels are used on trolley wire conductor systems for slow-speed industrial cranes, particularly where there is much vertical misalignment in the installation.

Type	Height in normal working position	Range of Movement	
		Up	Down
SW	11 ¹ / ₂ "	3 ⁵ / ₈ "	3"
KWL	16"	4"	5"

Features

Collector consists principally of malleable iron parts, the two lower arms being geared together at the base and controlled by a single adjustable tension spring assuring uniform pressure of the wheel on the conductor wire when running in either direction. In addition to the vertical movement, the entire pantograph is hinged at the base in order to give a slight horizontal movement to compensate for some misalignment in the conductor wire. Contact wheels are high quality bronze, 4¹/₄" diameter in the Type SW and 8" diameter in type KWL. Large 8" wheel, obviously provides greater contact wearing surface and less tendency to leave the wire.

Feeder connections can be made to either or both of the upper arms in holes provided with set screws for securing the cable.

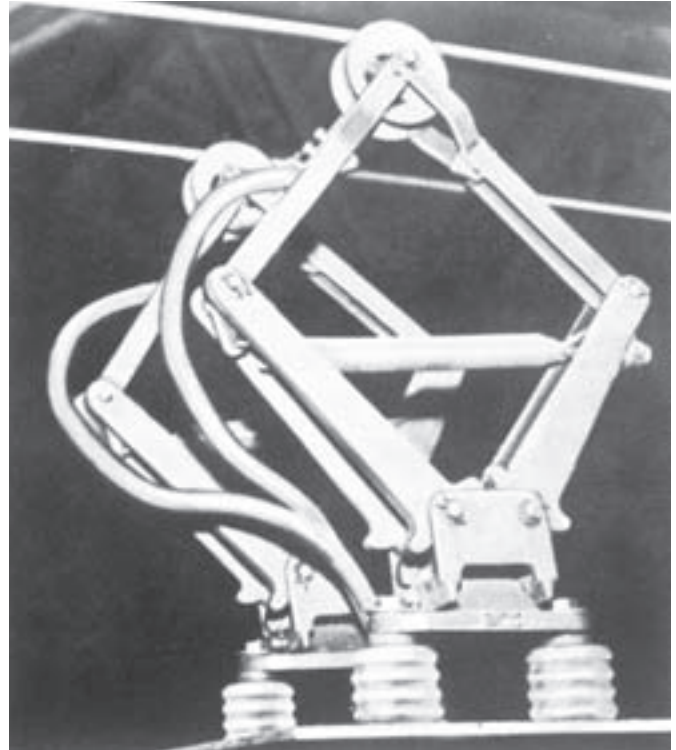

Typical Application of two pantographs in service

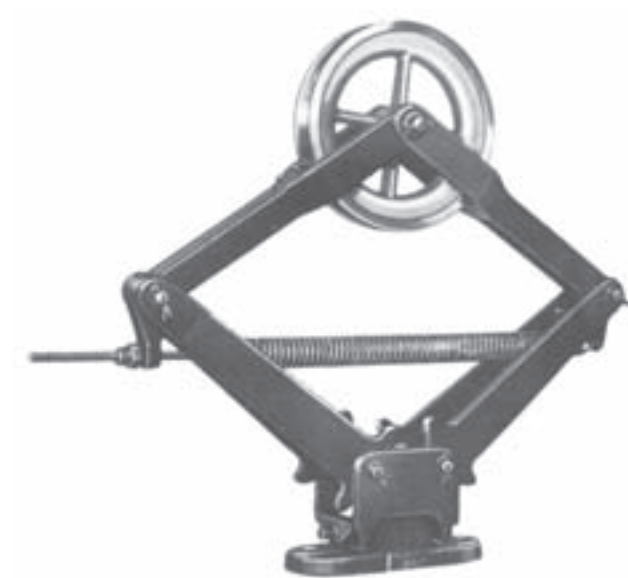

Type "KWL"

**Collectors - Pantograph
Wire Conductor Series**

46516

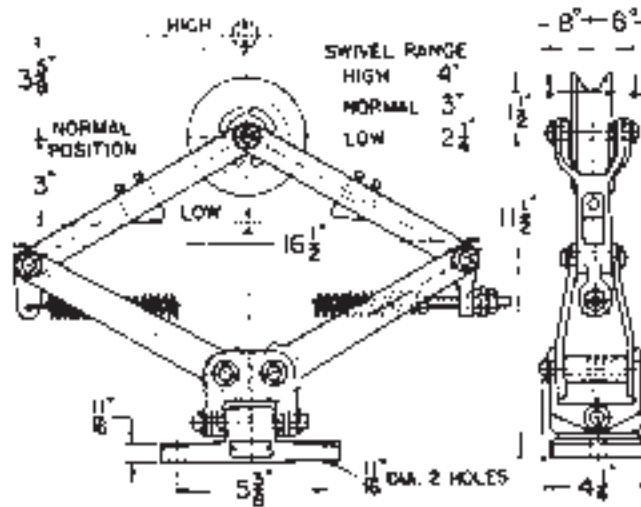

70086

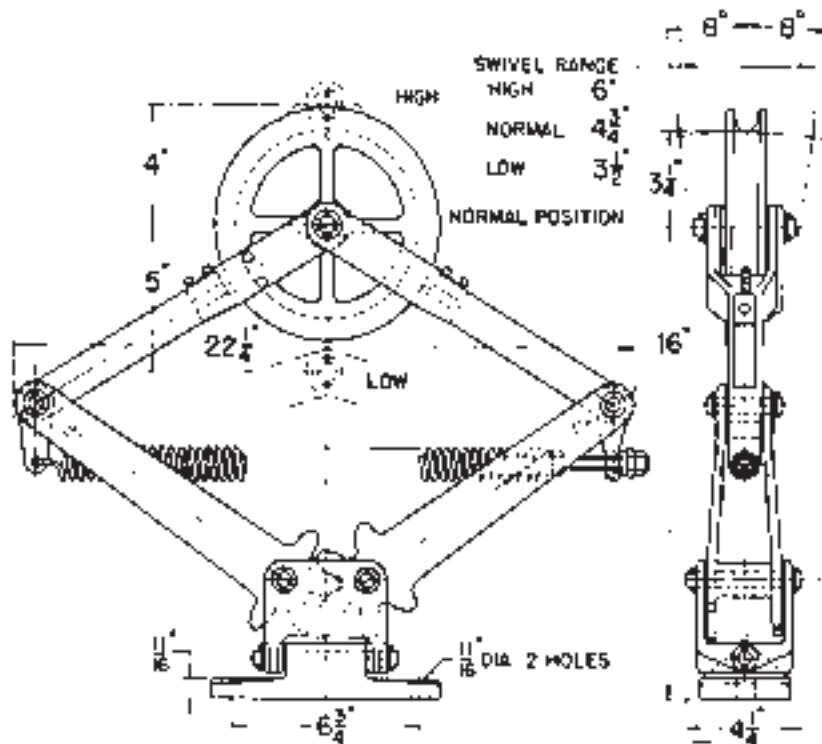

Catalog Information

Description	Contact Wheel Number	*Approx. Current Capacity Amperes	Approx. Wt. Each — Lbs.	Catalog Number
Pantograph Collector Type SW — 4 1/4"	18897	75	17	46516
Pantograph Collector Type KWL — 8" Wheel	48384	125	37	70086

* This rating is approximate due to changes in working conditions.

Ordering Directions - Specify by Catalog Number.

Collectors - Pantograph Rigid Conductor Series

Application

Pantograph Collectors with shoes are used with rigid conductors such as angles, tees and bars on collector systems for slow-speed industrial cranes, particularly where there is much vertical misalignment in the installation.

Type	Height in normal working position	Range of Movement	
		Up	Down
SA	11 ⁷ / ₈ "	3 ⁵ / ₈ "	3"
KA	16 ¹ / ₄ "	4"	5"

Features

Collector consists principally of malleable iron parts, the two lower arms being geared together at the base and controlled by a single adjustable tension spring assuring uniform pressure of the contact member on the conductor when running in either direction. Cast iron shoe with carbon inserts used in #46628 and 48287 pantograph collectors has a contact surface of 2¹/₂" x 6" but when equipped with the steel plate assembly the contact surface is increased to 5" x 8". Where there is considerable arcing necessitating more frequent replacement of the contact and excessive horizontal misalignment of the conductor bar, the use of the steel plate is recommended.

Feeder connections in the #46628 and 48287 pantographs are provided by means of a terminal attached to the contact member. Similar connections in #48480 and 48271 pantographs are made to a 1/2" hole with set screws to the casting supporting the contact plate.

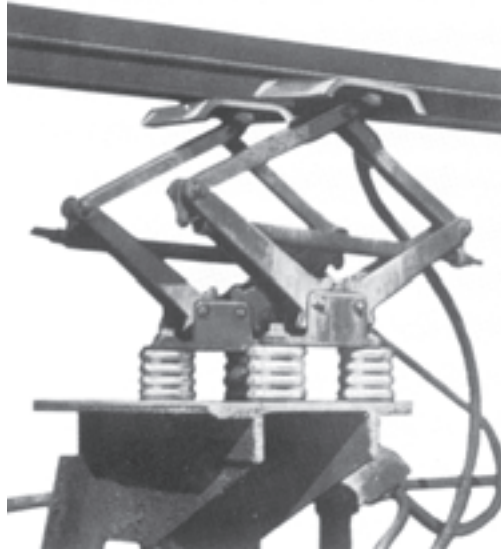

Pantograph with contact plate assembly



Type "KA"

Collectors - Pantograph Rigid Conductor Series

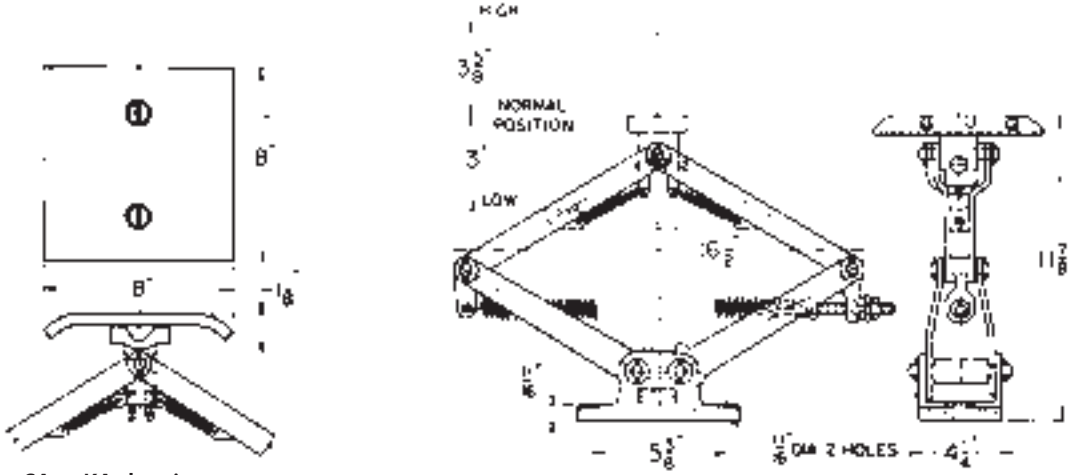

Types SA or KA showing arrangement with plate assembly

46628

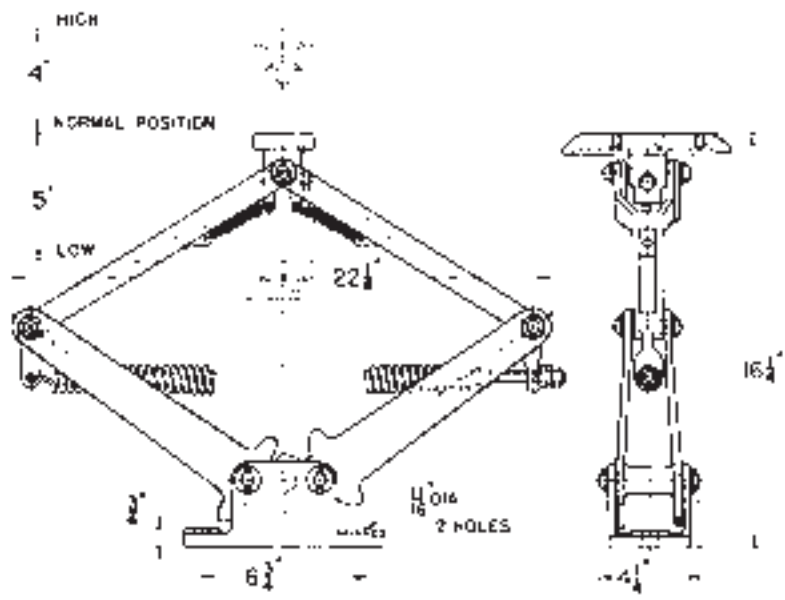

48287

Catalog Information				
Description	Contact Number	*Approx. Current Capacity Amperes	Approx. Wt. Each — Lbs.	Catalog Number
Pantograph Collector Type SA — with shoe	93121 — Shoe	125	17	46628
Pantograph Collector Type SA — with plate	48272 — Plate 48321 — Shoe	125	27	48480
Pantograph Collector Type KA — with shoe	93121 — Shoe	125	29	48287
Pantograph Collector Type KA — with plate	48272 — Plate 48321 — Shoe	125	39	48271

* This rating is approximate due to variations in operating conditions, but is based on employing full contact surface.

Ordering Directions - Specify by Catalog Number.

Collectors - Shoe Type For Rigid Conductors

Application

LMI, LM and LMV Collectors listed on the following pages are of the heavy duty type for use on conductor systems with rigid conductors as used on crane runways and similar installations. Underrunning is preferable in installations subject to sleet, snow and dirt conditions.

In areas of excessive dirt contamination, the Type LMV Collector used with an inverted angle conductor is recommended.

Individual types vary in size and style of contact member.

Features

Collectors consist of an assembly of a vertical mounting frame plus a spring loaded arm supporting the contact member. Adjustable spring assures proper contact with the conductor and may be varied to meet the particular working conditions.

Types LMI, LM Pony and LM Standard are assembled in the factory for either overrunning or underrunning service. Correct catalog number should be selected from the listing shown on the following pages. Mounting frame is provided with a corrugated surface around an elongated slot interlocking with a corrugated washer for vertical adjustment.

Feeder connections are made to a bronze solderless connector on the mounting frame. Flexible copper cable connects the terminal lug and the contact member, thus bridging and bonding the hinged portion.

Replaceable contact member on all styles with the exception of the LMV, are reversible, thereby providing increased life. These contact members have a swiveling action to allow for any slight misalignment in the conductor.

Replaceable contact members and insulators for mounting these collectors are available. A Polyester fiberglass insulator is generally preferred for this application. Comparative features of each series are shown on page 21.

LMV Pony
Generally used on the following conductors:
2" or 2 1/2" angles

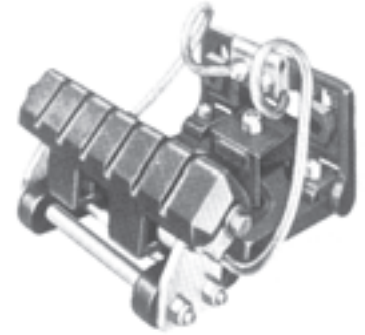

LM Pony
Generally used on the following conductors:
tees and angles
30 lbs. rail or under

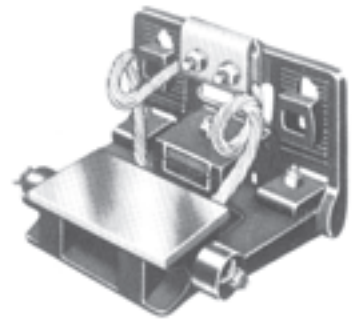

LMI Pony
Generally used on the following conductors:
tees and angles
30 lb. rails or under

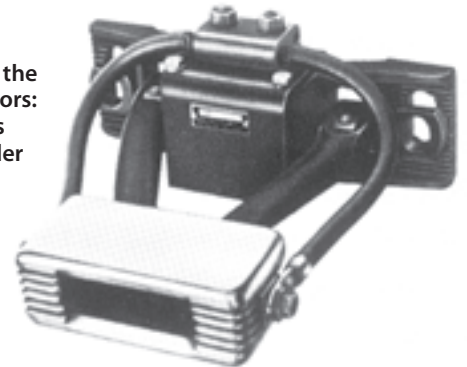

LM Standard
Generally used on the following conductors:
tees and angles
40 lbs. rail or above

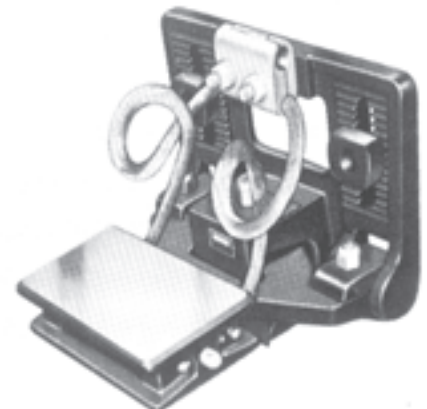

**Collectors - Shoe Type
For Rigid Conductors
LMV Pony Size**

Features

LMV Collectors are designed for use where the contact rail consists of an inverted "V" angle, either 2" x 2" or 2 1/2" x 2 1/2". Contact members are provided with self cleaning grooves so much of any foreign matter accumulating will be dislodged and will drop away from the contact surface. 98669 LMV collector is provided with a contact member which allows a horizontal movement of 1" for misalignment of the conductor. 98911 is similar in design except it is provided with an added plate construction, so arranged to provide a 2" horizontal movement where excessive misalignment of the conductor system is encountered.

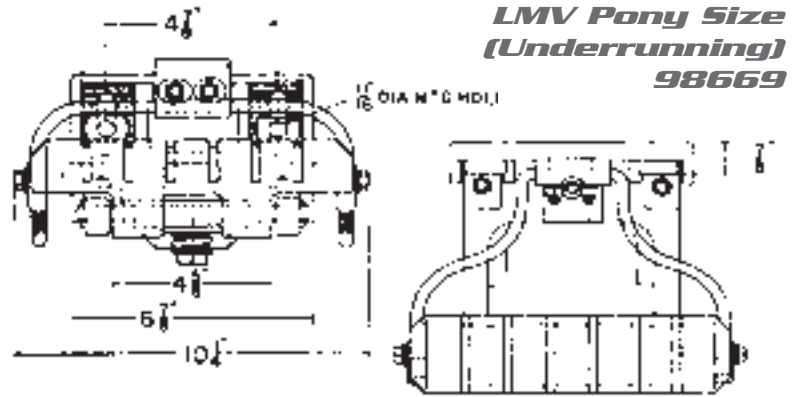

**LMV Pony Size
(Underrunning)
98669**

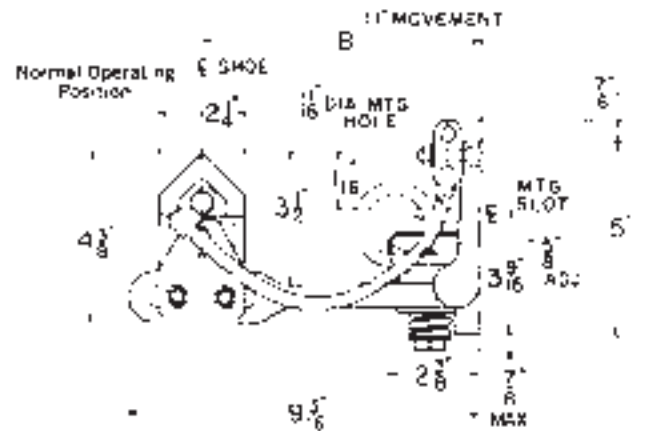
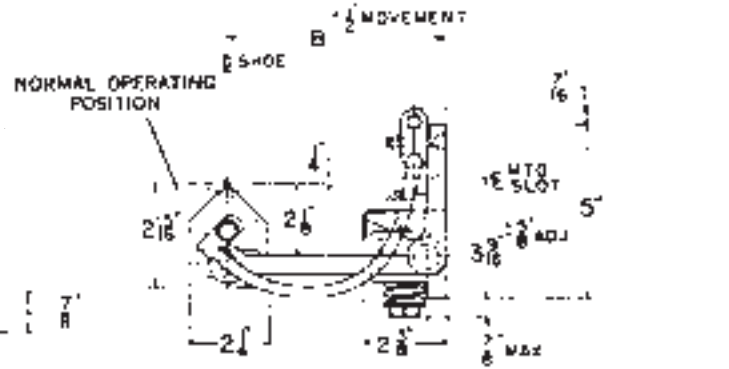
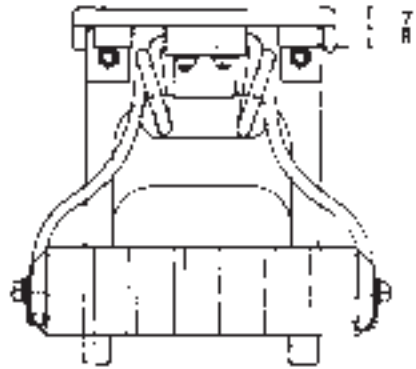

**LMV Pony Size (Underrunning)
98911**

Catalog Information

Description	Extension B	Horizontal Movement	Contact Member	*Range		Net Wt. Each — Lbs.	Catalog Number
				Up	Down		
LMV Collector — Underrunning	6 1/8"	1"	92930	3/4"	1 3/8"	14.25	98669
LMV Collector — Underrunning	7 3/8"	1 5/8"	92930	1"	1 5/8"	17.75	98911

* Range measurements apply to the vertical range with the collector in a horizontal position and measured from the point at the center of the member.

† When ordering, specify by catalog number.

**Collectors - Shoe Type
For Rigid Conductors
LMI Pony Size**

Features

LMI Collector has been designed with a short overall height to conserve vertical space in multiple collector installations. Open center design and fins provide a large radiating surface, high overload capacity and a minimum of weight moving part.

LMI Pony Size
95659 (Overrunning)
95660 (Underrunning)

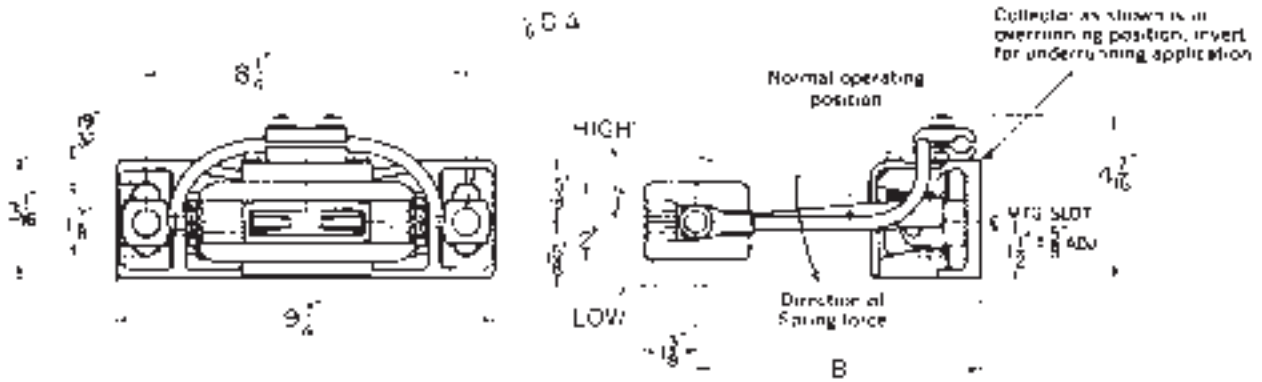
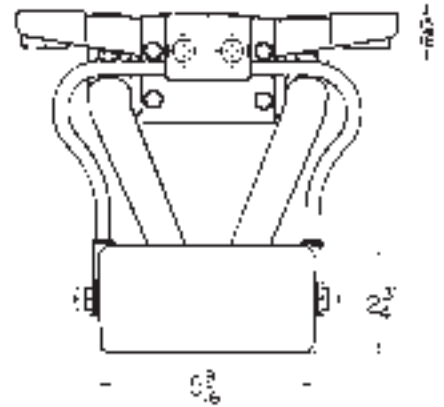

Catalog Information

Description	Extension B	Contact Member	*Range		Net Wt. Each — Lbs.	Catalog Number
			Up	Down		
LMI Collector — Overrunning	7 3/8"	88810	1 5/8"	1 5/8"	16	95659
LMI Collector — Underrunning	7 3/8"	88810	1 5/8"	1 5/8"	16	95660

* Range measurements apply to the vertical range with the collector in a horizontal position and measured from the point at the center of the member.

† When ordering, specify by catalog number.

**Collectors - Shoe Type
For Rigid Conductors
LM Pony Size**

Features

LM Pony and the LM Standard are similar in design, the LM Standard series being roughly twice the size of the LM Pony series and consequently has twice the current carrying capacity. Detailed characteristics of the two types are shown in this section. LM Standard series has a larger range of arm extension to suit numerous installation requirements.

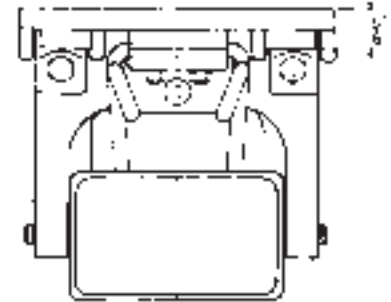

LM Pony Size (Underrunning)
98637
98634

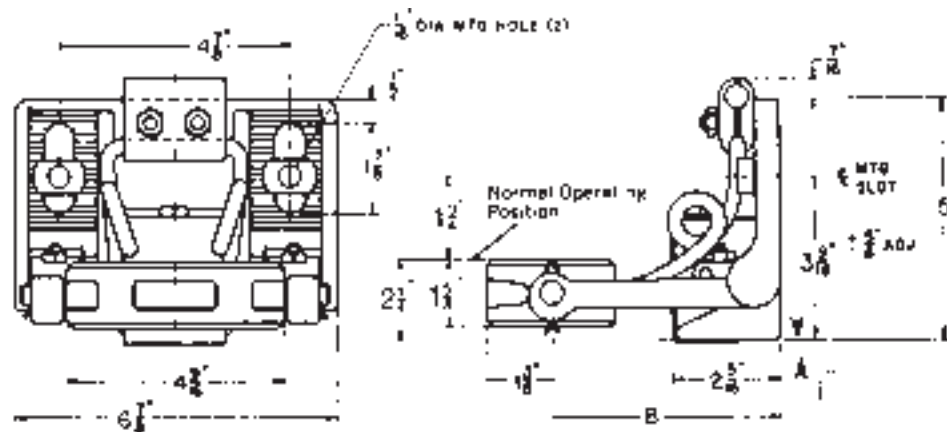
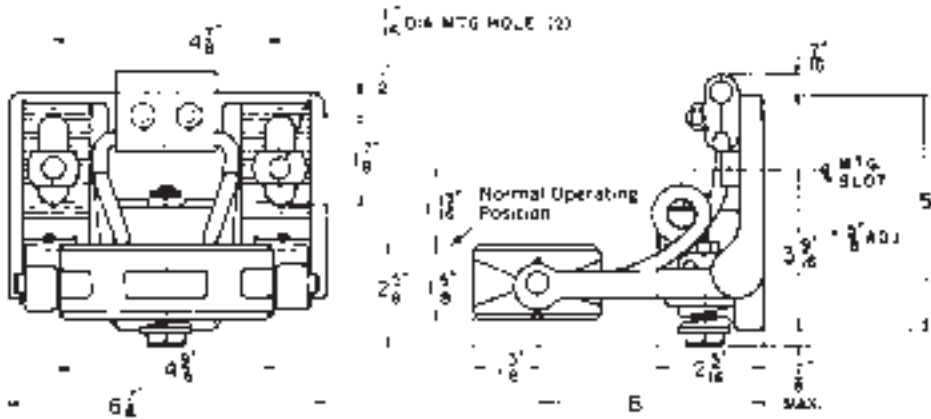

LM Pony Size (Overrunning)
76512
76514

Catalog Information

Description	Extension B	Contact Member	*Range		Net Wt. Each — Lbs.	Catalog Number
			Up	Down		
LM Pony — Underrunning	4 ¹⁵ / ₁₆ "	45650	5 ⁵ / ₈ "	1"	12	98637
LM Pony — Overrunning	4 ¹⁵ / ₁₆ "	45650	1"	5 ⁵ / ₈ "	12	76512
LM Pony — Underunning	7 ³ / ₈ "	45650	1"	1 ⁵ / ₈ "	13	98634
LM Pony — Overrunning	7 ³ / ₈ "	45650	1 ⁵ / ₈ "	1"	13	76514

* Range measurements apply to the vertical range with the collector in a horizontal position and measured from the point at the center of the member.

Ordering Directions - Specify by Catalog Number.

**Collectors - Shoe Type
For Rigid Conductors
LM Standard Size**

Features

LM Pony and the LM Standard are similar in design, the LM Standard series being roughly twice the size of the LM Pony series and consequently has twice the current carrying capacity. Detailed characteristics of the two types are shown in this section. LM Standard series has a larger range of arm extension to suit numerous installation requirements.

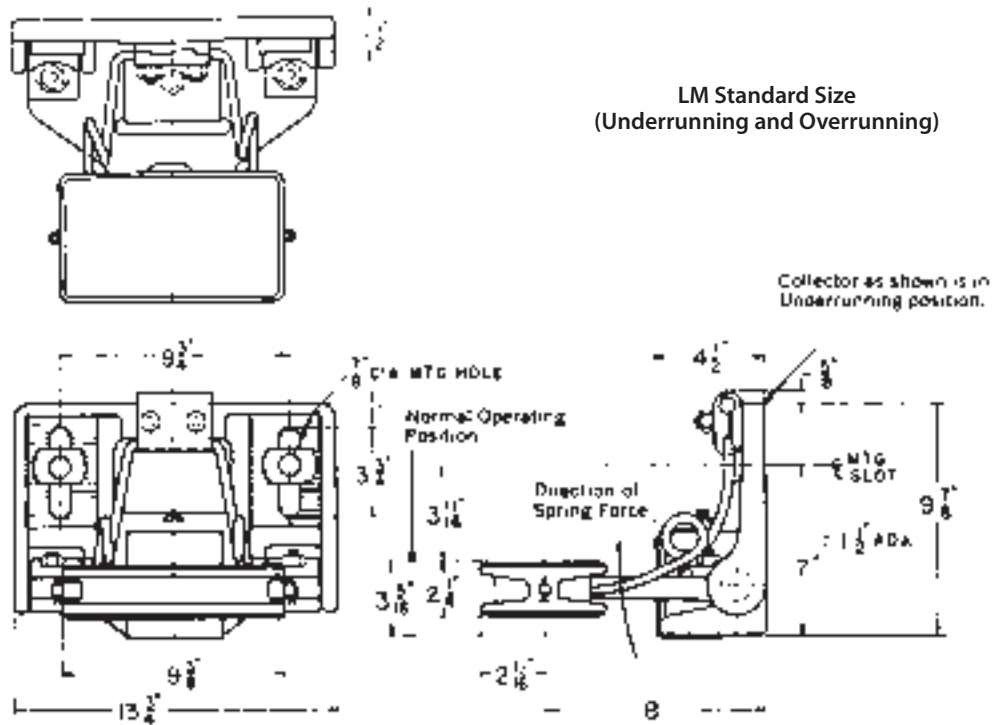

**LM Standard Size
(Underrunning and Overrunning)**

Collector as shown is in Underrunning position.

Catalog Information

Description	Extension B	Contact Member	*Range		Net Wt. Each — Lbs.	Catalog Number
			Up	Down		
LM Standard — Underrunning	9 ⁵ / ₁₆ "	45715	1"	1 ¹ / ₄ "	67	45712
LM Standard — Overrunning	9 ⁵ / ₁₆ "	45715	1 ¹ / ₄ "	1"	67	76507
LM Standard — Underrunning	10 ¹³ / ₁₆ "	45715	1 ¹ / ₄ "	1 ³ / ₈ "	69	45713
LM Standard — Overrunning	10 ¹³ / ₁₆ "	45715	1 ³ / ₈ "	1 ¹ / ₄ "	69	76508
LM Standard — Underrunning	12 ⁵ / ₁₆ "	45715	1 ¹ / ₂ "	1 ³ / ₄ "	71	45714
LM Standard — Overrunning	12 ⁵ / ₁₆ "	45715	1 ³ / ₄ "	1 ¹ / ₂ "	71	76509
LM Standard — Underrunning	15 ¹ / ₁₆ "	45715	1 ⁷ / ₈ "	2 ¹ / ₂ "	75	48474
LM Standard — Overrunning	15 ¹ / ₁₆ "	45715	2 ¹ / ₈ "	2 ¹ / ₈ "	75	76510

* Range measurements apply to the vertical range with the collector in a horizontal position and measured from the point at the center of the member.

Ordering Directions - Specify by Catalog Number.

**Collectors - Shoe Type
For Rigid Conductors
Type PS Collector**

Application

Type PS Collector with its exceedingly heavy construction is adaptable for severe service on pushing machines and quenching locomotives in coke oven operation.

Features

Collector consists primarily of rugged cast iron assembly, the extension arm is made from ductile iron designed to provide a pantograph action whereby the shoe contact member is always in line with the rail regardless of any normal amount of vertical or horizontal misalignment of either the contact or the running rails or both.

Heavy compression spring assures uniform pressure of the contact member on the conductor. A dust cover is provided to protect against contamination.

Main fulcrum points of the assembly are provided with bearings and the main shaft bearing is in addition provided with an oil cup.

Large replaceable shoe has a smooth contact surface of about 9" x 9". It is provided with two flexible braided copper shunts, each of which is provided with feeder terminals for 500 MCM cable.

Type PS collectors are supplied with four mounting holes. They can be mounted on four #89791 insulators.

Provision is made for vertical adjustment of the mounting height by means of a corrugated surface around an elongated mounting slot plus interlocking corrugated washers under the mounting bolts.

Replaceable contact members are available.

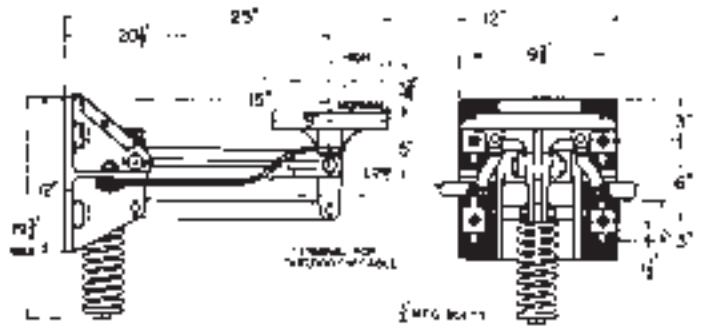

Catalog Information				
Description	Contact Member	*Approx. Current Rating Amperes	Net Wt. Each — Lbs.	Catalog Number
Type PS Underrunning Collector	77864	750 Constant 1500 Intermittent	185	75745
* Current carrying capacities are approximate as they depend upon conditions of installation such as speed, contact pressure, frequency of use, cleanliness of surfaces, etc.				

Ordering Directions - Specify by Catalog Number.

Collectors - Shoe Type For Rigid Conductors

<i>Comparison Chart</i>				
	LMV Pony Series	LMI Pony Series	LM Pony Series	LM Standard Series
Approx. Current Capacity (Amperes) Average Conditions				
• Continuous Load	300	250	250	550
• Intermittent Load	600	500	500	1000
Contact Member	Two Contact Surfaces, each 1 $\frac{1}{2}$ " x 9" including cleaning grooves. Cast Iron. Non-reversible.	Contact Surface 2 $\frac{3}{4}$ " x 5 $\frac{9}{16}$ " Cast Iron. Copper Coated. Reversible.	Contact Surface 2 $\frac{1}{2}$ " x 4 $\frac{1}{2}$ " Cast Iron. Reversible.	Contact Surface 5" x 9" Cast Iron Reversible.
Bronze Cable Terminals	Adjustable for wire diameters .414" to .528.	Adjustable for wire diameters .414" to .528.	Adjustable for wire diameters .414" to .528.	Adjustable for wire diameters .536" to .772.
Service	Underrunning	Under or Overrunning	Under or Overrunning	Under or Overrunning
Height of Mounting Back	5"	3 $\frac{1}{16}$ "	5"	9 $\frac{7}{8}$ "
Vertical Adjustment of Corrugated Mounting Washer	1 $\frac{1}{4}$ "	1 $\frac{1}{4}$ "	1 $\frac{1}{4}$ "	3"
Mounting Bolt Diam. (Not Included with Collectors)	$\frac{5}{8}$ "	$\frac{5}{8}$ "	$\frac{5}{8}$ "	$\frac{3}{4}$ "
(Mounting Bolt Length depends on Mounting conditions.) Thickness of back and corrugated washer	$\frac{15}{16}$ "	$\frac{15}{16}$ "	$\frac{15}{16}$ "	1 $\frac{1}{2}$ "

***Collectors - Contact Members
For Rigid or Wire Conductors***

Applications

The replaceable contacts for rigid or wire conductors in this section are those used with collectors previously listed.

Ratings are shown with the collectors. Bronze contacts in place of cast iron contacts are available in most sizes.

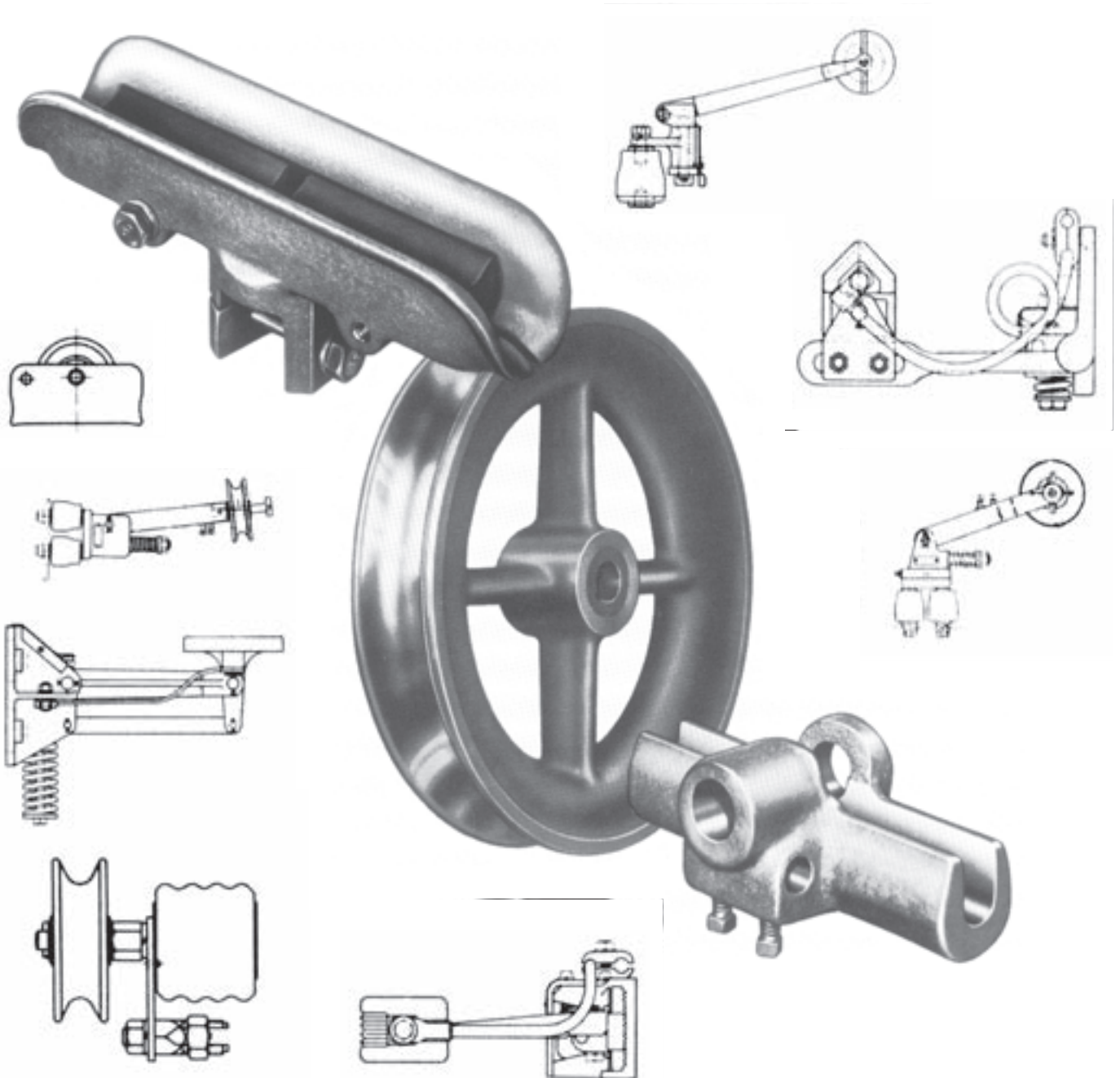

**Collectors - Contact Members
For Rigid Conductors**

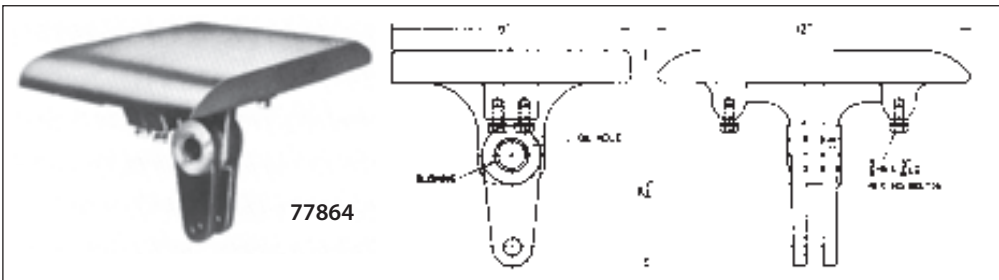
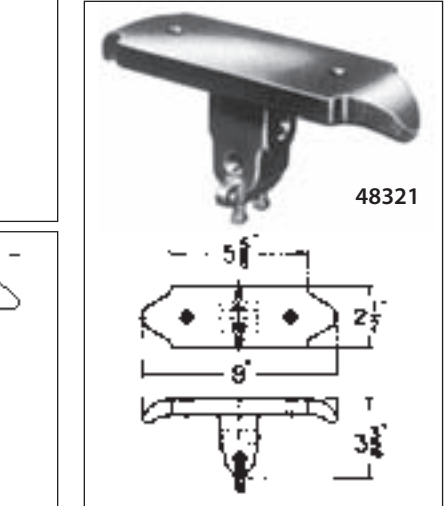
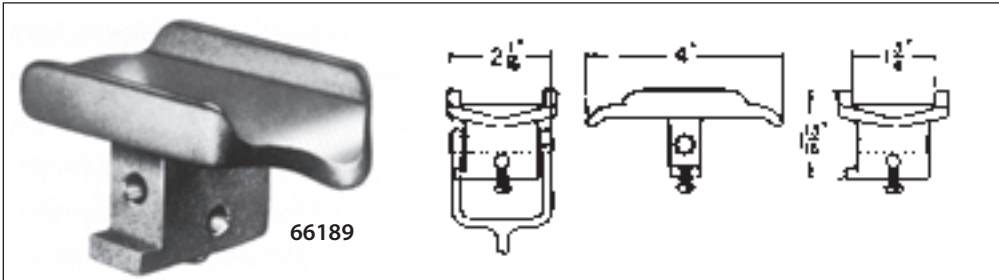
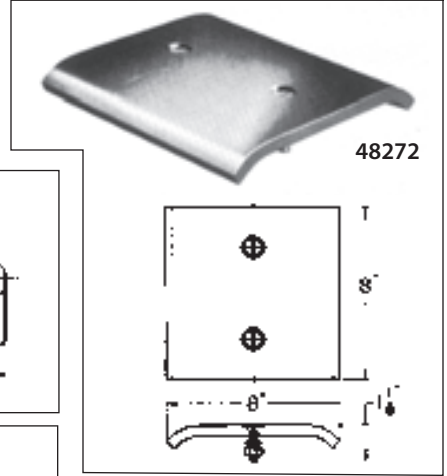
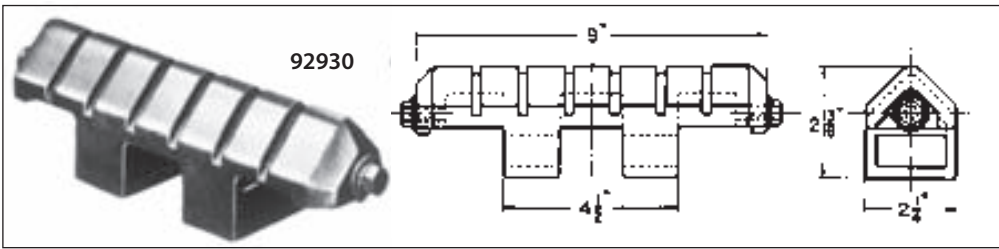
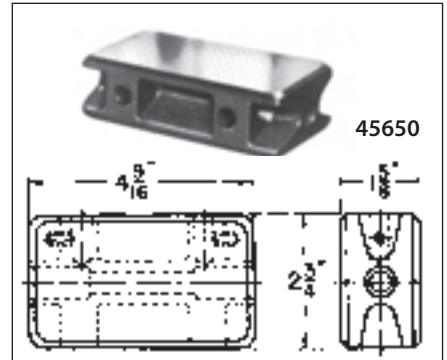
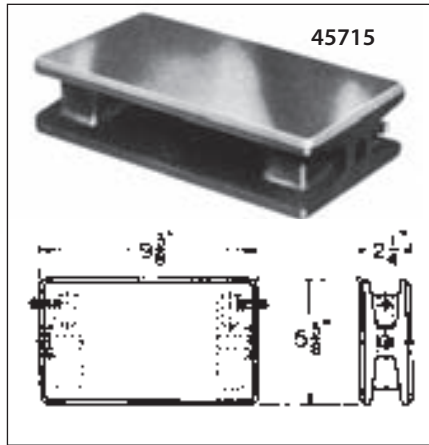
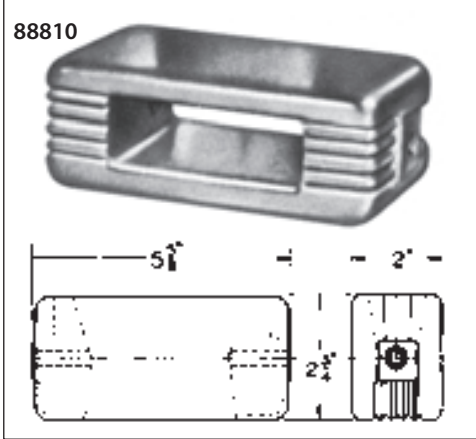

Catalog Information

Description	Used on Collector	Net Wt. Each — Lbs.	Catalog Number
Cast Iron — Reversible Shoe	LMI — 95659, 95660	5.75	88810
Cast Iron — Reversible Shoe	LM Pony — 76512, 44276, 76514, 45674	3.125	45650
Cast Iron — Reversible Shoe	LM Standard—45712, 76507, 45713, 76508, 45714, 76509, 48474, 76510	18.75	45715
Cast Iron — Shoe	LMV — 67388, 78514, 98911, 986510	5.50	92930
Cast Iron — Shoe	PS — 72446, 75745	40.50	77864
Cast Iron — Support Only	Pantograph — 48480, 48271	13.00	48321
Steel plate contact for Cat. No. 48321	Pantograph — 48480, 48271	4.00	48272
Cast Bronze Shoe	Junior — 66188, 67263	1.25	66189

**Collectors - Contact Members
For Rigid Conductors**

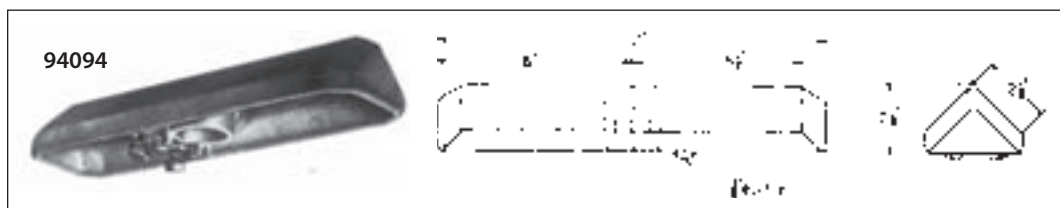
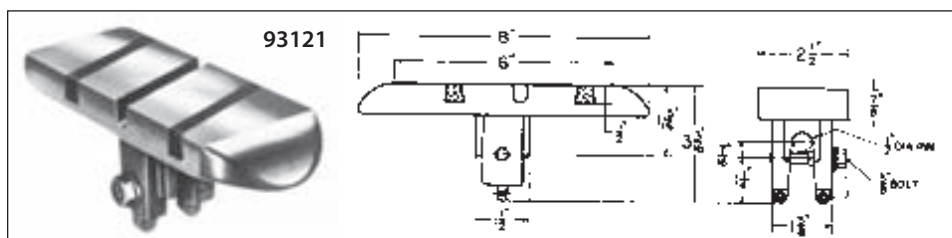
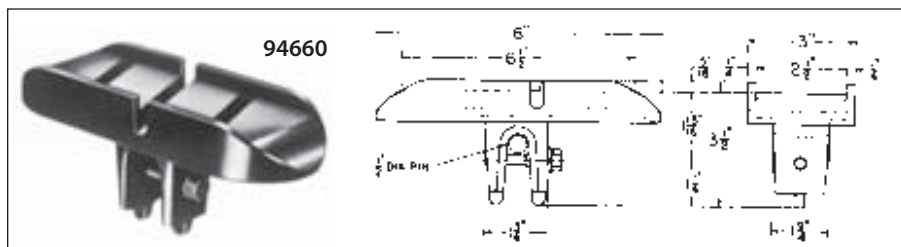
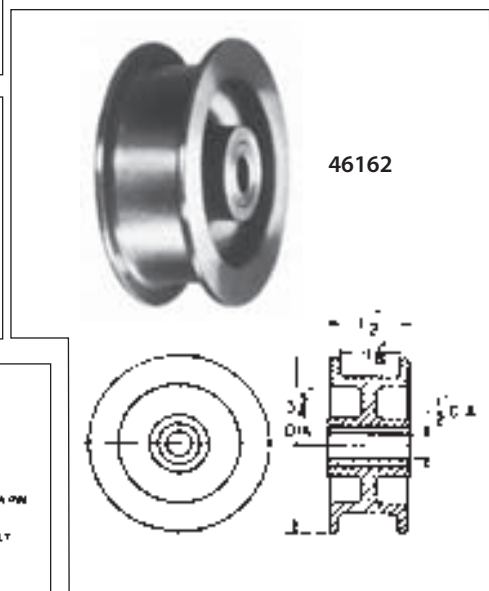
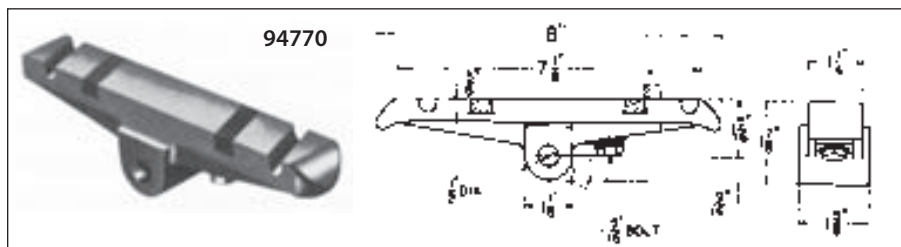
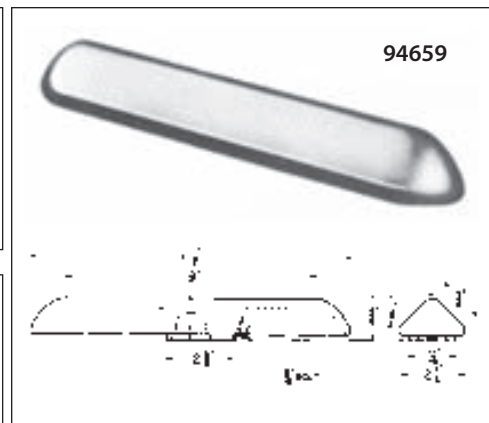
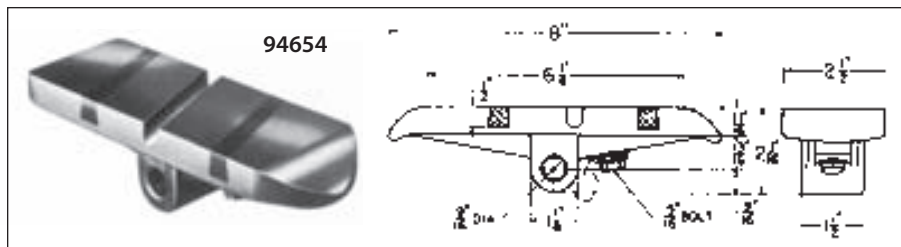

Catalog Information			
Description	Used on Collector	Net Wt. Each — Lbs.	Catalog Number
Cast Iron Shoe with Carbon Inserts	Universal — 46192, Pantograph — 46628, 48287	4.00	93121
Bronze Wheel	Universal — 46227	2.25	46162
Cast Iron Shoe with Carbon Inserts	Universal — 94060, 94102	4.25	94654
Cast Iron Shoe with Carbon Inserts	Universal — 92868, 94103	2.00	94770
Cast Iron Shoe with Carbon Inserts	Universal — 94106	5.25	94660
Cast Iron Shoe	Universal — 94058	3.40	94659
Cast Iron Shoe	Universal — 94059	7.00	94094

Ordering Directions - Specify by Catalog Number.

**Collectors - Contact Members
For Wire Conductors**



18897



46488



48384



60047



46615



62918

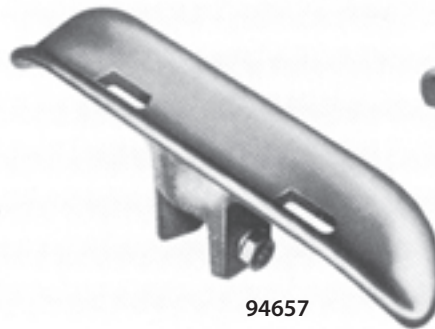

94657



94658
94661

Catalog Information

Description	Used on Collector	Net Wt. Each — Lbs.	Catalog Number
Bronze Wheel — Spoked	46199, 46211 Universal 70545 Type PW, 46516 Pantograph	1.88	18897
Bronze Wheel — Solid	46492 Type BW	.69	46488
Bronze Wheel — Spoked	70086 Pantograph	7.13	48384
Bronze Wheel — Solid	60036, 60141 Junior	.88	60047
Bronze Shoe	46491 Type BV	1.81	46615
Bronze Shoe	62920, 60141 Junior	2.25	62918
Bronze Shoe	93148 Universal	2.38	94657
Bronze Shoe with Standard Inserts	92944 Universal	2.69	94658
Bronze Shoe with High Capacity Inserts	94136 Universal	3.63	94661
Standard renewable contact only	92944	.13	88321
High Capacity renewable contact only	94136	.44	88597

Ordering Directions - Specify by Catalog Number.

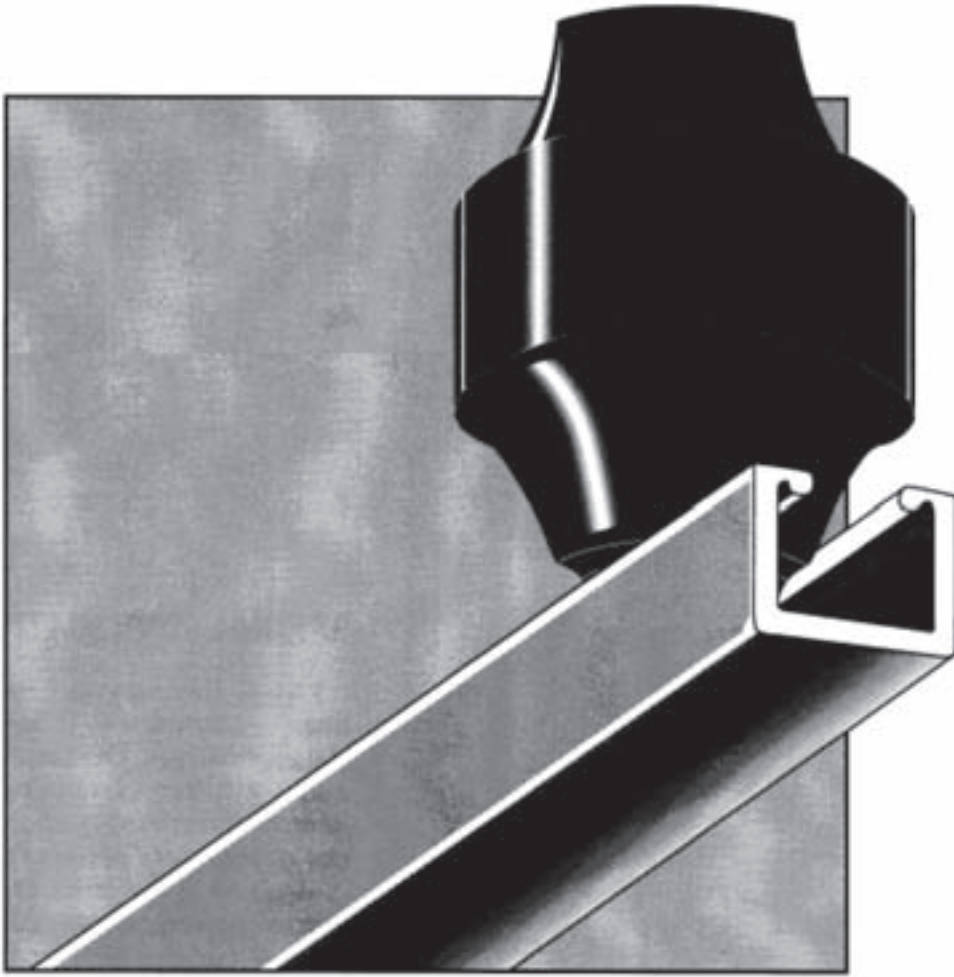

Introduction

The C-Bar Conductor System is a medium capacity system for use where load current requirements do not warrant the use of our high capacity integrated systems. The compactness, rugged design, and economy make this an ideal Conductor System for all types of A.C. and D.C. current collection applications. C-Bar may be mounted with the conductor surface in any plane. Under and side running are the most common mounting positions. The C-Bar Conductor is available in 350 Amp. Bronze Conductor, 450 Amp. Aluminum Conductor and 550 Amp. Copper Conductor. Standard Collectors are available from 25 to 275 ampere capacities.

This entire system is supplied as a package complete with insulators, hangers, conductors and collectors, ready to mount on building or structural supports.

Lightweight design and erection simplicity reduces installation costs in comparison to other types of systems. No field welding, drilling or cutting is required. Assembly is accomplished by means of standard hex wrenches. Conductors are furnished in factory pre-cut lengths to fit your requirements. Installation and application drawings, engineered for the job, accompany each system and locate the various components for erection.

Our sales personnel and engineering staff are available for aiding in the selection of the most economical system for your present and future requirements.

C-Bar

Typical Installations

The C-Bar Conductor System, due to its medium capacity can serve a wide range of applications. It is ideal for applications inside or outside, on main runway and cross travel for traveling cranes, material handling units, machine tools, rotary kiln temperature recording, etc.

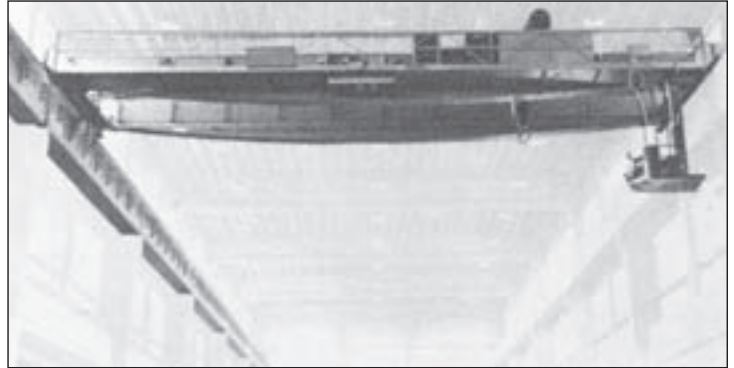

Special Applications

The C-Bar system has been widely used to fit special applications. The Senate Subway C-Bar system has been in operation for a number of years. Its application is unusual since the C-Bar system powers subway cars around curves. A later installation was the House of Representatives subway that also required curved track sections.

An interesting and unusual application is the St. Louis Arch. Passengers are loaded in cars below the base and transported to the top of the Arch. These cars receive their power from a C-Bar system that is curved for almost the entire length of the system.



St. Louis Arch



Senate Subway

Conductor

The C-Bar Conductor section is available in three materials; Bronze, Aluminum, and Copper, with nominal 350, 450, and 550 ampere capacity, respectively. Ampere ratings are based on a 30°C rise over a 40°C ambient in still but unconfined air. The box-like construction provides high mechanical rigidity and allows a large surface area for heat dissipation and current collection. Conductors are of non-magnetic materials to reduce voltage drop.

Conductors are normally furnished in 30 foot lengths. "L" as specified in catalog number is length-hence, the catalog number for a 30 foot copper conductor section would be 99341-30. Shorter lengths are available for use where system clearances will not allow insertion of the standard 30 foot length. Fractions of a foot should be avoided; i.e.: if a 16'6" section is required, order a 17 foot section and cut to required size.



Bronze



Aluminum



Copper

Conductor Characteristics			
Conductor	Bronze	Aluminum	Copper
Catalog Number	99823-L	99418-L	99341-L
Cross-Sectional Area	355 MCM	457 MCM	355 MCM
D.C. Resistance / 1,000 ft. @ 20°C-OHMS.	.10426	.04125	.02945
Conductivity % IACS 20 C	28	56	99
A.C. Resistance / 1,000 ft. @ 20°C-OHMS.	.10582	.0421	.0300
Self GMD (Ds) inches	.51	.491	.48
Current Ratings* Continuous	30°C over 40°C	350	450
	40°C over 40°C	450	550
	70°C over 40°C	550	650
Weight per foot - lbs.	1.07	.428	1.07
*Ratings are based on the average indicated temperature rise of new conductors in still but unconfined air.			

Insulated Hanger

The Insulated Hanger is used to support the conductor section and to electrically insulate it from the supporting structure.

The Insulated Hanger is positioned within the C-Bar Conductor; as shown in the C-Bar cut away. The conductor can slide freely over the hanger to allow movement from expansion and contraction due to temperature changes.

It is normally recommended that insulated hangers be used every five (5) feet along the conductor run.

The insulators are polyester fiberglass, with a 5/8" mounting tap, and are recommended for indoor or outdoor installations.

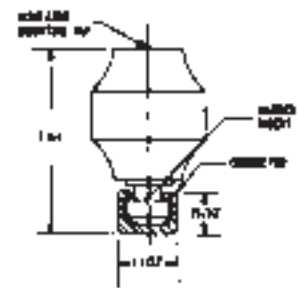
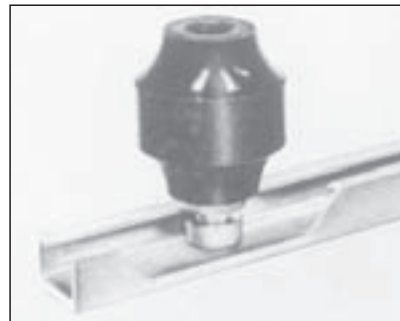

Insulator Material		Polyester Fiberglass
Catalog Number		105430
Standard Color		Red
Creepage Distance - Inches		2 1/2
Dielectric Strength	Dew Flashover	15
	KV	Dry, S. T.
Tensile Strength - Lbs.		3,500
Cantilever Strength - Lbs.*		1,000
*Measured at center line of hanger insert.		

Splice Joint Assembly

The Splice Joint joins the C-Bar Conductor as shown in the cutaway view.

The splice joint assembly is used to join and align adjacent conductor sections. It is easily installed with no drilling required.

The splice joint maintains positive alignment and provides electrical continuity. The two adjacent conductors are solidly clamped between a tongue-like bar and a clamping plate. Four high strength bolts insure a firm mechanical and electrical connection.

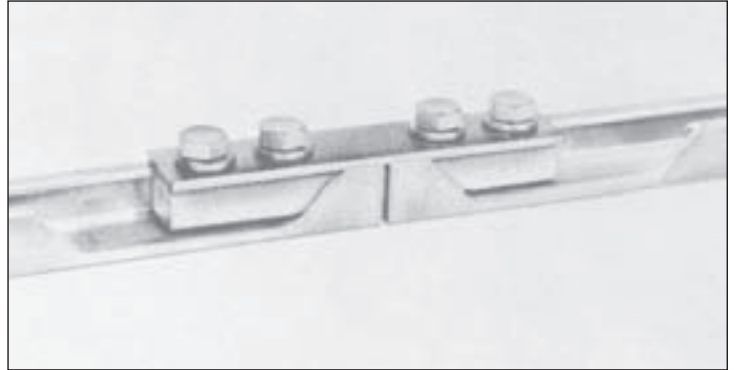
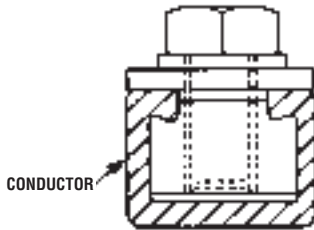

System	Splice Joint Catalog No.	Splice Joint Rating*
Aluminum	96945	450
Copper/ Bronze	98361	550
*Based on a 30°C rise over 40°C ambient, still air.		

Anchor Assembly

The Anchor Assembly shown in the cutaway view illustrates the mechanical barriers within the C-Bar Conductors which are used in conjunction with an insulated hanger to secure the conductor at some pre-determined point in the system.

Anchors are used in conjunction with Insulated Hangers to restrict the longitudinal movement of the conductors. They prevent creeping of the conductor and unnecessary stressing of the Insulated Hangers throughout the system.

On systems under 200 feet long, anchors are placed at the center of the system.

On systems over 200 feet long, anchors used in conjunction with expansion joints are employed to control the direction of expansion and contraction of conductor sections.

Note: The insulated hanger is not included with the anchor assembly and must be ordered separately.



System	Anchor Catalog Number
Bronze	98752
Aluminum	98746
Copper	98752

Feeder Assembly

The Feeder Assembly is shown in the cutaway view installed in the C-Bar Conductor.

The Feeder Assembly provides electrical connections to the C-Bar Conductor System.

It may be located at any point in the system, but should be kept at least six (6) inches away from nearest component (hangers, etc.), as contact with these components will prevent free sliding of the conductor during expansion and contraction.

Feeder Assembly includes feeder lug, hardware, and clamping bar.

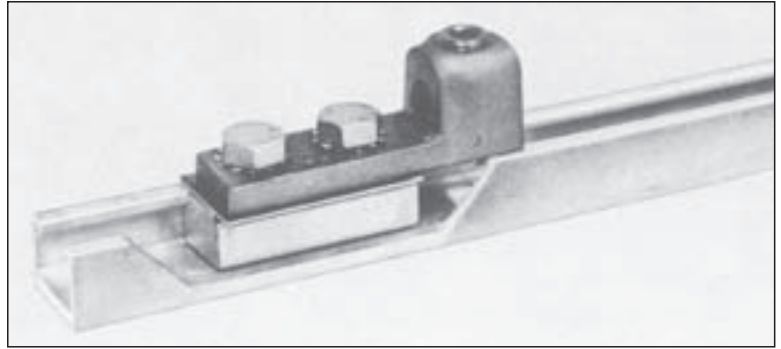

Feeder Wire Size	Feeder Assembly Catalog No. Aluminum, Bronze & Copper Systems
#16 to #14 #12 to #10 #8 Solid to #6 Str. #4 Solid to #1 Str. #2 to 2/0 Str. 1/0 to 4/0 Str. 3/0 to 300 MCM 300 to 500 MCM 500 to 800 MCM	Contact Trans Tech

Expansion Joint Assembly

The Expansion Joint Assembly illustrated in the cutaway view shows how it joins conductors and maintains electrical continuity by means of a flexible copper braided conductor.

The expansion joint, in conjunction with anchors, is used to accommodate the difference in expansion between the conductor and the structure on which the system will be supported.

The expansion joint will accommodate a maximum movement of 3/4". The flexible copper braid carries the current across the gap between conductors.

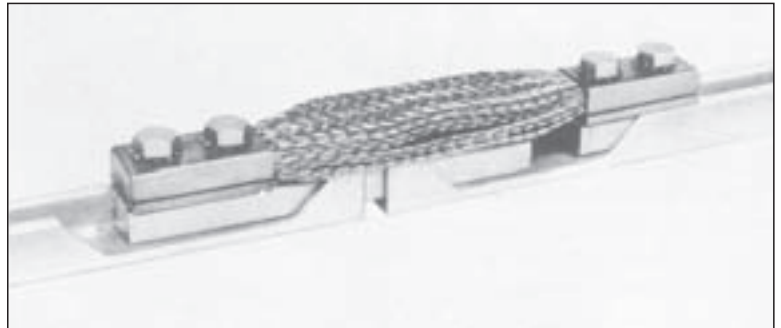

System	Expansion Joint Cat. No.	Rating*	Dim. "A" Maximum	
			Indoor	Outdoor
Bronze	96059	350	200'	140'
Aluminum	96035	450	150'	100'
Copper	96079	550	200'	140'

*Based on a 30°C. rise over 40°C. ambient, still air.

TYPICAL APPLICATION

NOTE: Conductor gap setting is based on both the ambient temperature at the time of installation and the expected temperature variation to which the system will be exposed.



Isolating Joint

The Isolating Joint is used to insulate adjacent conductor sections from each other without interfering with collector travel. It allows portions of the system to be electrically disconnected while operations continue on other live sections. The air gap between C-Bar Conductors should be 1 1/4" maximum.

At installations where more than one crane will be operated on a single conductor system, the isolating joint is used to create maintenance and repair bays.

The isolating joint may be inserted at any point along the system in place of a standard splice joint assembly. When properly installed, it assures correct alignment between adjacent conductors.

There are two methods of feeding the conductor system at isolation joints. Each side can be fed individually through adequate safety switches, or the isolation joint can be by-passed with the use of feeder assemblies and a suitable switch.

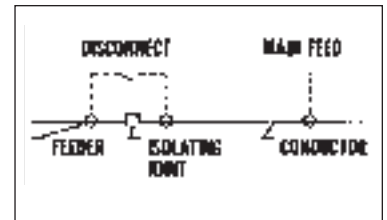
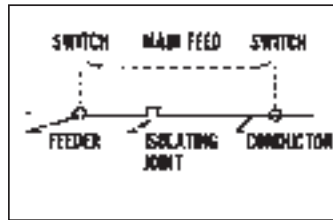
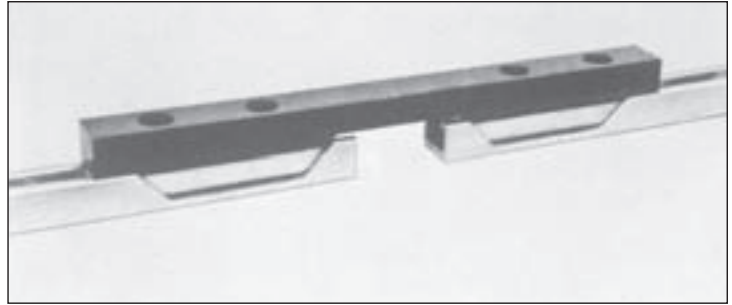

System	Insulating Joint Catalog No.*
Aluminum	9955201
Copper/Bronze	9955202

*Isolating Joint Assembly does not include feeder assemblies or switches, but is complete with hardware .

Covered C-Bar Conductor System

Insulated C-Bar Conductor Systems are available. They provide protection with an extremely tough electrical grade thermoplastic jacket suitable for indoor or outdoor installation.

Conductor sections up to 30 feet in length are furnished assembled with jacket, hangers, or other components required for the particular application. The jacket is red in color for safety purposes and can be removed without disturbing the system.

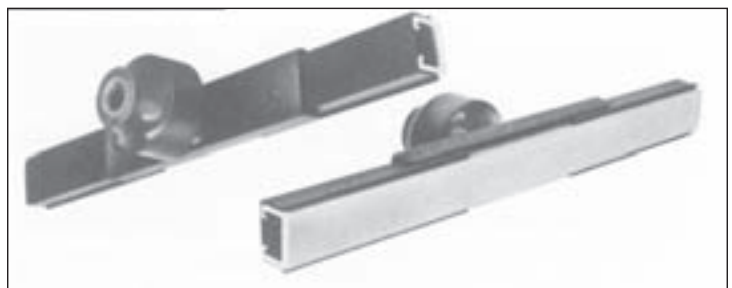

Run-Off Conductor

Run-off Conductors are used to provide a break in the conductor system where runways are interrupted by railroad crossings, roads, etc.

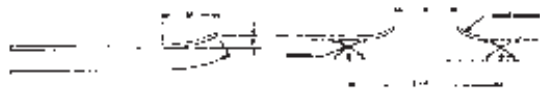

Two collectors are required to insure continuous operation across the runway interruption. Only cross-arm collectors can be used on systems with run-off conductors.

Power must be supplied to both sides of the runway interruption in a manner similar to that illustrated in the isolating joint wiring diagrams.

"L" as specified in catalog number is length in feet; hence, a 20 foot aluminum run-off conductor would be 14-00181-20. Fractions of a foot should be avoided.

Single-Arm Collectors

Single-arm collectors are available for various current ratings, depending on such factors as shoe material, conditions of service, type of installation, etc.

All single-arm collectors listed are identical except for the contact blocks and mounting arrangement. The contact blocks are interchangeable between all collectors. They are quickly removed by loosening two bolts on the assembly. Replaceable contact blocks are listed separately. Contact shoe pressure is controlled by adjusting the spring location in the slots of the collector base. Power connection (by customer) is to be made at shunt connection on mounting base. Mounting insulators or insulated mounting boards are not included with the collector assembly and must be ordered separately.

RUN-OFF Conductor			
	Bronze	Aluminum	Copper
Catalog Number	Contact Trans Tech		

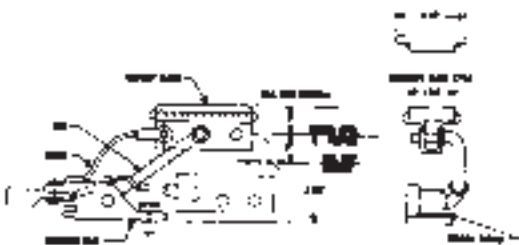
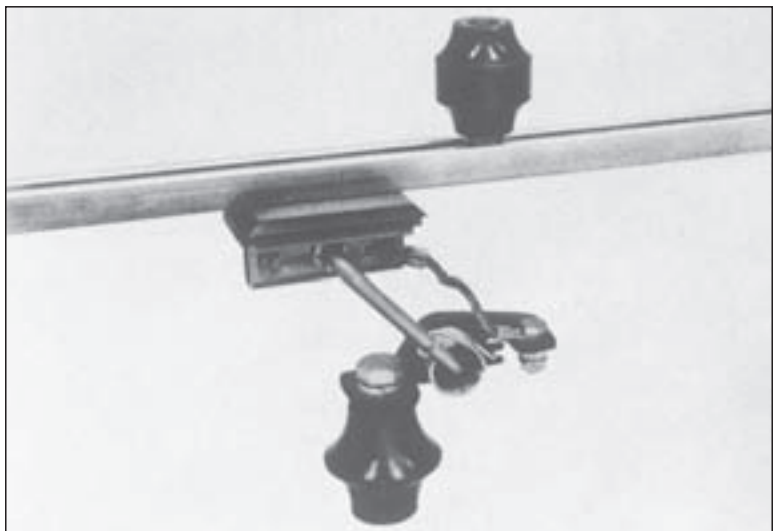

Collector Cat. No.	Conductor System	Current Rating**			Inches		Contact Block Material	Contact Block Cat. No.
		30° C. Rise	40° C. Rise	50° C. Rise	A min.	B		
99389-01	Bronze	25	30	50	3	2	Electro-graphitic Carbon*	1 ³ / ₄ wide 99412
	Aluminum	25	30	50				
	Copper	30	35	60				
99389-02	Bronze	75	100	150	3	2	Metal graphite	1 ³ / ₄ wide 99413
	Aluminum	100	125	200				
	Copper	125	150	250				
99389-05	Bronze	25	30	50	3 ¹ / ₂	2 ¹ / ₂	Electro-graphitic Carbon*	2 ¹ / ₂ wide
	Aluminum	25	30	50				
	Copper	30	35	60				
99389-06	Bronze	75	100	150	3 ¹ / ₂	2 ¹ / ₂	Metal graphite	2 ¹ / ₂ wide 99715
	Aluminum	100	125	200				
	Copper	125	150	250				

*Indoor System Only.
 **The ratings given are based on the average indicated temperature rise over a 40°C. Ambient in still, but unconfined air. Conductors spaced at 3".

Cross-Arm Collectors

Cross-arm collectors are available for various current ratings, depending on such factors as shoe material, conditions of service, type of installation, etc.

All cross-arm collectors listed are identical except for the contact shoe blocks and mounting arrangement. The contact blocks are interchangeable between all single and cross-arm collectors. They are quickly removed by loosening two bolts on the assembly. Replacement contact blocks are listed separately.

Contact shoe pressure is controlled by spring force adjustment. This is accomplished by relocating the spring in the holes provided in the contact block holder. Adjustable stops are provided to control maximum operating height for run-off applications on interrupted crane runways.

Mounting insulators or insulated mounting boards are not included with the collector assembly and must be ordered separately.



Collector Cat. No.	Conductor System	Current Rating**			Inches		Contact Block Material	Contact Block Cat. No.
		30° C. Rise	40° C. Rise	50° C. Rise	A min.	B		
99634-01	Bronze	50	60	100	3	2	Electro-graphitic Carbon*	1 ³ / ₄ wide 99412
	Aluminum	50	60	100				
	Copper	60	75	120				
99634-02	Bronze	175	200	350	3	2	Metal graphite	1 ³ / ₄ wide 99413
	Aluminum	225	250	450				
	Copper	275	300	550				
99634-05	Bronze	50	60	100	3 ¹ / ₂	2 ¹ / ₂	Electro-graphitic Carbon*	2 ¹ / ₂ wide
	Aluminum	50	60	100				
	Copper	60	75	120				
99634-06	Bronze	175	200	350	3 ¹ / ₂	2 ¹ / ₂	Metal graphite	2 ¹ / ₂ wide 99715
	Aluminum	225	250	450				
	Copper	275	300	550				

*Indoor System Only.
 **The ratings given are based on the average indicated temperature rise over a 40°C.
 Ambient in still, but unconfined air. Conductors spaced at 3".

Tracking Shoe Collector

The tracking shoe collectors are recommended for curved rail systems or systems where extreme horizontal misalignment is present. The collectors are not recommended for side running operation.

The contact force is adjustable to meet special operating conditions.

Mounting insulators or insulated mounting boards are not included with the collector assembly and must be ordered separately.

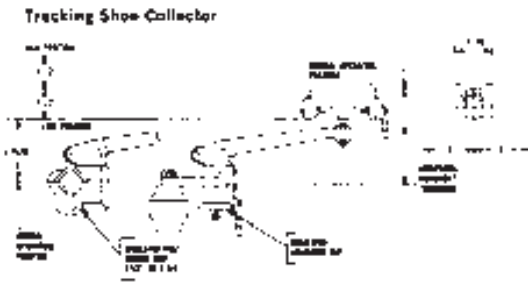
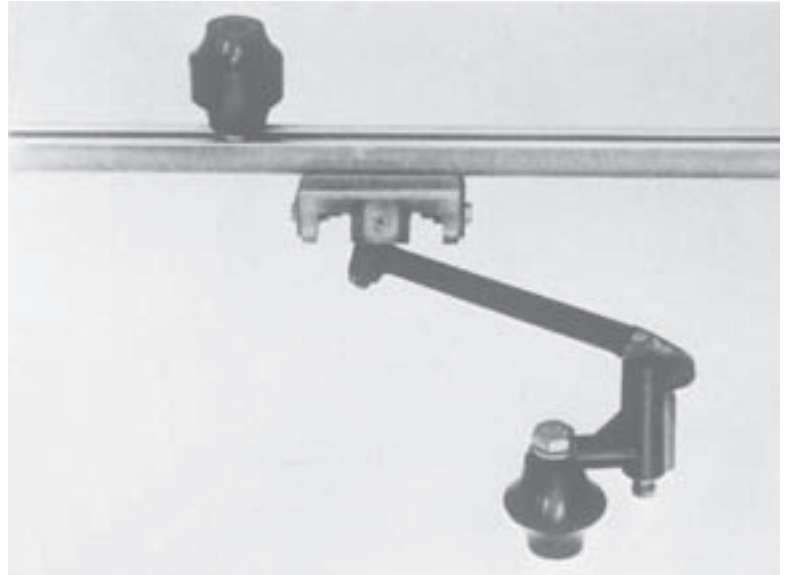

Collector Cat. No.	Conductor System	Current Rating** 40°C. Ambient			Inches A min.	Contact Block Material	Contact Block Cat. No.
		30°C. Rise	40°C. Rise	50°C. Rise			
105396	Bronze Aluminum Copper	75 100 125	100 125 150	150 200 250	3	Metal Graphite	1" wide 105385

**The ratings given are based on the average indicated temperature rise over a 40°C.
Ambient in still, but unconfined air. Conductors spaced at 3".

Collector Mounting Insulators



Insulator Catalog Number		A	B
		Red-Poly #15-51-35	Red-Poly #15-61-17
Material		Polyester Fiberglass	
Creepage Distance -Inches-		2 1/2"	3
Dielectric Strength KV	Dew-KY Flashover	15	17
	Dry-KV Short-Time	38	40
Tensile Strength — Lbs.		3,500	5,000
Cantilever Strength Inch-Pounds		3,000	4,500

TECHNICAL DATA

CONDUCTOR SIZE CALCULATION

There are two accepted methods of determining the maximum ampere demand of one or more cranes on a single runway.

Method A

Maximum load equals the sum of all main and auxiliary hoist H.P. plus one-half (1/2) the sum of all bridge motor and trolley H.P.

Method B

Maximum load equals one-half (1/2) the sum of all motor and accessory H.P.

CALCULATION

Load H.P. (Method A or B) x amperes per H.P. (Table A) = maximum ampere demand.

Maximum ampere demand x crane factor (Table C) = adjusted maximum ampere demand.

VOLTAGE DROP CALCULATION

Symbols

VL = Line Voltage at Feeder (Source).

VD = Voltage Drop.

I = Load Amperes.

L = Effective System Length in Feet. Maximum distance from feeder to end of system.

Roc = D. C. Resistance-ohms/1000 feet.

K = Voltage Drop Multiplier (Table B). A factor derived from tests which accounts for variables such as A. C. resistance, inductive reactance, power factor, phase spacing, and conductor shape factors.

Formulas

Direct Current

$$VD = \frac{ILRoc}{500}$$

Alternating Current - Three Phase

(80 percent Power Factor-Flat Spacing)

$$VD = I L K \text{ (Line to Line*)}$$

*For Line to Neutral Voltage Drop divide by 1.73.

Voltage Regulation

$$\% \text{ Regulation} = \frac{VD}{VL - VD} \times 100$$

Example

Length of runway, 200 feet, operating on 440 volts, 3 phase, 60 cycle, phase spacing 3 inches, feeder location-center of runway, one crane on runway. By Method "A," the maximum ampere demand would be calculated as follows:

	ACTUAL H.P.	CALCULATED H.P.
Main Hoist	90	90
Auxiliary Hoist	100	100
Bridge	150	75
Trolley	30	<u>15</u>
		Total 280 H.P.

From Table A multiplier is 1.5. 1.5 x 280 H.P. = 420 maximum ampere demand. Based on a 30°C rise over 40°C ambient, you could select the 450 aluminum C-Bar series for this application.

From Table B, the 450 Series with a 3 inch phase spacing has a K multiplier of 115.6 x 10⁻⁶ - therefore:

$$VD \text{ (Voltage Drop)} = I \times L \times K$$

$$VD = 420 \times 100 \times (115.6) (10^{-6}) \\ = 4.86 \text{ volts}$$

$$\% \text{ Regulation} = \frac{VD}{VL - VD} \times 100$$

$$\text{Regulation} = \frac{4.86}{440 - 4.86} \times 100 = 1.12\%$$

TABLE A
Amperes Per Horsepower Conversion

Current	Voltage	Multiplier*
D.C.	115	8
	230	4
	600	1.6
A.C. (3 ϕ)	110	7.0
	220	3.0
	440	1.5
	550	1.2
	2300	0.25
A.C. (2 ϕ)	110	6.0
	220	2.6
	440	1.3
	550	1.1
	2300	0.21

*Average conversion factors calculated from National Electric Code Full Load Current Motor Charts. Motors built for especially low speeds or high torques may require more running current. In which case, name-plate or design current ratings should be used.

TABLE C
CRANE FACTOR (C²)

Current	Multiplier*
1	1
2	0.95
3	0.91
4	0.87
5	0.84

*In the event there are two or more cranes operating on the same load side of the feeder, the multiplying factors shown in Table C would be applied to the maximum ampere demand calculated by Method A or B.

TABLE B

C-Bar Conductor Series	"K"-Voltage Loss Multiplier X 10 ⁻⁶										
	Conductor Phase Spacing — Inches										
	3	3 1/2	4	4 1/2	5	5 1/2	6	7	8	9	10
Bronze 350	191.5	193.1	194.9	196.1	198.5	200.6	205.4	206.4	210.0	212.3	215.4
Aluminum 450	115.6	119.0	122.6	124.8	127.2	129.6	132.2	135.8	139.0	142.0	144.6
Copper 550	90.4	93.6	96.4	98.9	101.4	103.8	106.0	109.6	112.4	114.9	116.2

Expansion Gap Setting Guide

The following chart is provided as a means of determining the initial expansion gap setting, depending upon application ambient conditions.

The chart should be used according to the following procedure:

- (a) Determine local ambient temperature range. Example -20 to 100°F.
- (b) Starting at point X on A scale, write in the ambient range starting at highest expected ambient and decrease in 10 degree increments to the lowest expected ambient.
- (c) Determine ambient temperature at time of gap setting. From the existing ambient temperature, A scale, read across to the curve and down to the gap setting. Adjust conductor accordingly.

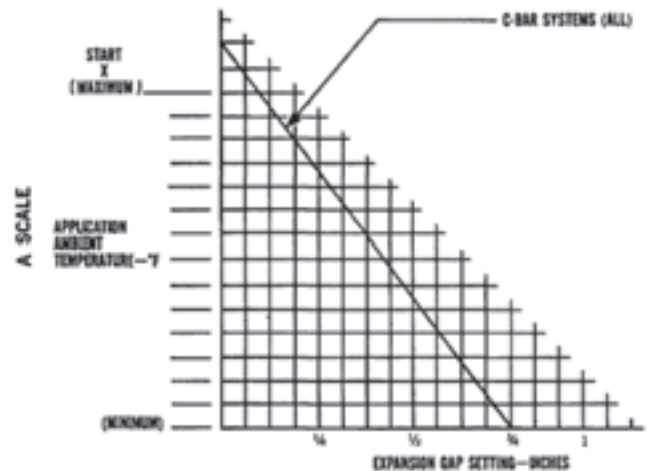

TYPICAL SPECIFICATIONS

System - General

Each system shall consist of necessary conductor sections, hanger supports, insulators, anchor supports, expansion joints, joint plates and collectors, as determined from plans and specifications. All component parts shall be of standardized design and fully interchangeable. Engagement of the conductor with all other components of the system shall be effected without drilling, welding, or alteration of the conductor and associated components.

The conductor system shall be of the C-Bar type as manufactured by Trans Tech.

Conductors

The current carrying conductors shall be made of (bronze) (aluminum) (copper) and shall have a continuous current carrying capacity of (350)(450) (550) amperes per rail based on a 30°C rise over a 40°C ambient. The conductors shall have sufficient thermal capacity to sustain a 300% overload for intermittent duty loads. The conductor section shall be a one-piece (bronze) (aluminum) (copper) conductor of uniform extruded cross-section so as to present a smooth, flat surface for current collection. The conductor shall have a minimum cross-sectional area of 355 MCM (bronze), 457 MCM (aluminum), 355 MCM (copper), and shall be of box-like configuration for mechanical rigidity.

The complete rail system shall consist of standard conductor lengths aligned in end-to-end relationship. Aligning and joining means between conductor section shall be accomplished by a special extruded bar which shall engage the conductor sections and provide an interlocking key to eliminate misaligned meeting ends of adjoining rail sections. The conductor shall have a current collection surface one (1) inch wide.

Insulating Hangers

The conductor hanger shall support the conductor section, and shall insulate it from the structure to which it is mounted. The insulator shall be molded of fiberglass reinforced polyester material. The insulated hanger shall provide free

sliding of the conductor section due to expansion and contraction throughout the system. All insulating hanger hardware shall be $\frac{5}{8}$ - 11 thread size. The hanger design shall be such that it would be possible to turn the conductor 360 degrees about the vertical axis.

Splice Joints and Expansion Joints

Splice and expansion joints shall be provided to join adjacent conductor sections as required. The joints shall consist of special extruded bars which slip inside the conductor to provide an interlocking key to eliminate misalignment. In the standard joint assembly, the adjacent conductor sections shall be rigidly connected. In the expansion joint assemblies, the joint shall include a conductive flexible braid. All components shall be of sufficient size and electrical capacity to be compatible with the conductor rating. All joint assemblies shall have an electrical efficiency of greater than one hundred (100) percent.

Collectors

Collectors shall be rated on the basis of a 30°C rise over a 40°C ambient. The collectors shall have sufficient overload capacity to carry 300% of the rated current for starting and surge loads.

All collector assemblies shall be constructed of high quality material and shall be of sufficient size to withstand the abuse of the intended service conditions.

The contact shoes shall consist of a mounting support and interchangeable contact inserts. Contact shoe pressure shall be adjustable. All collector springs shall be cadmium plated. The contact shoes shall be capable of transversing all breaks and expansion gaps smoothly with a minimum of arcing.

Special Components

Isolating joint assemblies can be provided to allow shutdown of portions of the system while operations continue on other sections. The isolating joint assembly shall provide a $1\frac{1}{4}$ inch air gap between conductors, shall maintain positive alignment between them, and shall not hinder the passage of the collector contact shoes across the air gap.

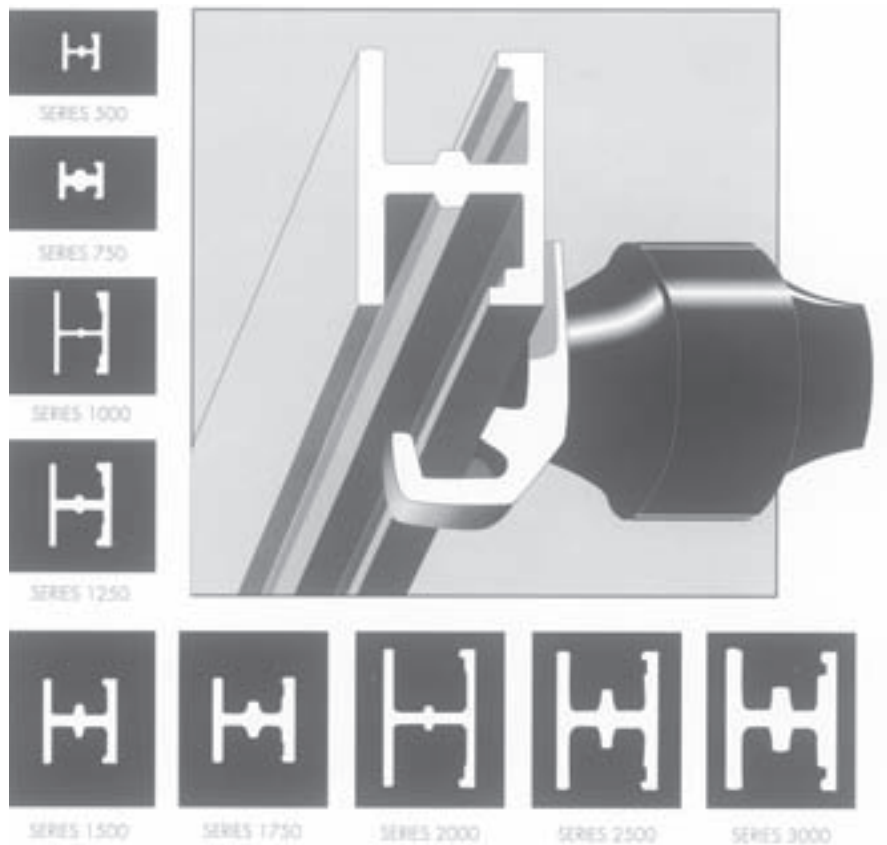

System Features

H-Bar Aluminum Conductor Systems provide an efficient and economical means to supply power to all types of cranes or other moveable equipment that require a constant source of electrical energy. Systems are available with ratings of 500, 750, 1000, 1250, 1500, 1750, 2000, 2500 and 3000 amperes. Larger systems are available to 10,000 amperes upon request.

Compactness of conductor and collector design allows installation with minimum spacing between conductors. This results in lower impedance on A.C. Systems and better voltage regulation characteristics. Good voltage regulation insures top performance of your equipment. Booster cables are no longer a necessity with an engineered H-Bar System.

Lightweight design and erection simplicity reduces installation costs in comparison to other types of systems. No field welding, drilling or cutting is required. Assembly is accomplished by means of standard hex wrenches. Conductors are furnished in pre-cut lengths to fit your requirements. Installation and application drawings engineered for the job accompany each system, locating the various components for erection.

The H-Bar Aluminum Conductor Systems can be used for A.C. or D.C. voltage applications including 4160 volts A.C. based on insulator selection.

A variety of metal enclosures designs are available for personnel protection under different mounting conditions. Again, simplicity of design along with engineered installation drawing. reduce erection costs.

Our sales personnel and engineering staff are available for aiding in the selection of the most economical system for your present and future requirements.

H-Bar

STANDARD COMPONENTS — System - Series									
Component	500	750	1000	1250	1500	1750	2000	2500	3000
Conductor	106100	106101	106102	106103	106104	106105	106106	106107	106108
Hanger Assembly	106125	106125	106126	106126	106126	106126	106127	106127	106127
Splice Joint Assembly	106130	106130	106131	106131	106132	106132	106133	106134	106135
Anchor Assembly	106140	106140	106141	106141	106141	106141	106142	106142	106142
Isolating Joint Assembly	106145	106145	106146	106146	106146	106146	106147	106147	106147
Fixed Expansion Joint Assembly	106150	106150	106151	106151	106152	106152	106153	106153	106154
Floating Assembly Joint (Bldg.)	106160	106161	106162	106163	106164	106165	106166	106167	106168
Feeder Assembly (Less Lugs)	106170 106171	106170 106171	106172 106173	106172 106173	106172 106173	106172 106173	106174 106175	106174 106175	106174 106175
Metalized Contact Conductor	106190	106191	106192	106193	106194	106195	106196	106197	106198

Conductor

The Aluminum H-Bar Conductor is designed for main runway or cross travel applications. It may be mounted with the conductor surface in any plane. Under or side running are the most common mounting positions. The "H" configuration was selected for its structural strength allowing maximum hanger spacing, thereby reducing installation costs. The conductor is extruded from high conductivity aluminum alloy in maximum 30 foot lengths. Shorter lengths are available (5 foot minimum) in one foot increments to coincide with your runway length requirements.

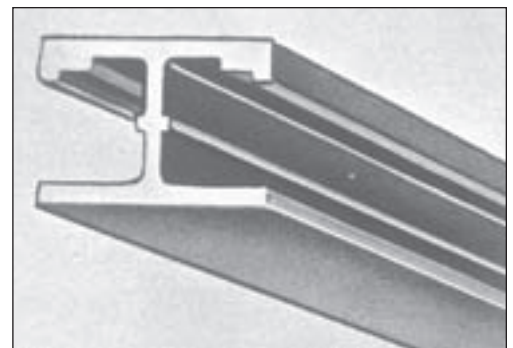

System Ampere Rating	Conductor Cat. No.	A	B	C	Cross Sectional Area		Weight Lbs/Ft.	DC Resistance Ohms/ 1000 ft. at 20° C.	AC Resistance Ohms/ 1000 ft. at 20° C.	Self Geometric Distance d s - Inches	Current Rating Amperes-Continuous 40° C. Ambient		
					Sq. Inches	CMx 10 ⁶					30° C. Rise	40° C. Rise	70° C. Rise
500	106100	1 ¹ / ₁₆	1	5 ⁵ / ₃₂	0.51	0.65	0.60	0.0292	0.0349	0.55	500	575	750
750	106101	1 ¹ / ₁₆	1 ¹ / ₄	1 ¹ / ₄	0.76	0.97	0.89	0.0196	0.0213	0.66	750	850	1100
1000	106102	2 ¹ / ₄	1 ¹ / ₂	3 ³ / ₁₆	1.14	1.45	1.34	0.0130	0.0150	0.81	1000	1150	1500
1250	106103	2 ¹ / ₄	1 ³ / ₄	1 ¹ / ₄	1.51	1.92	1.78	0.0098	0.0119	0.93	1250	1450	1850
1500	106104	2 ¹ / ₄	2	9 ⁹ / ₃₂	1.90	2.41	2.22	0.00784	0.0101	1.04	1500	1700	2200
1750	106105	2 ¹ / ₄	2 ¹ / ₄	1 ¹¹ / ₃₂	2.26	2.88	2.66	0.00655	0.00845	1.14	1750	2000	2600
2000	106106	3 ³ / ₄	2 ¹ / ₂	5 ⁵ / ₁₆	2.90	3.68	3.40	0.00513	0.00748	1.28	2000	2300	3000
2500	106107	3 ³ / ₄	2 ³ / ₄	3 ³ / ₈	4.01	5.11	4.72	0.00369	0.00611	1.49	2500	2850	3750
3000	106108	3 ³ / ₄	3	1 ¹⁷ / ₃₂	5.40	6.87	6.35	0.00274	0.00520	1.67	3000	3400	4500

Hanger Assembly

The hanger assembly is used to support the conductor section with the aid of an insulator. The hanger is made of cast aluminum, nylon coated to assure free sliding during expansion and contraction of the conductor through the hanger. Conductor "lock-up" has been eliminated by this added feature. The hanger, like the conductor, may be mounted in any plane.

Insulator selection depends on the operating voltage of the system and the hanger bolt size.

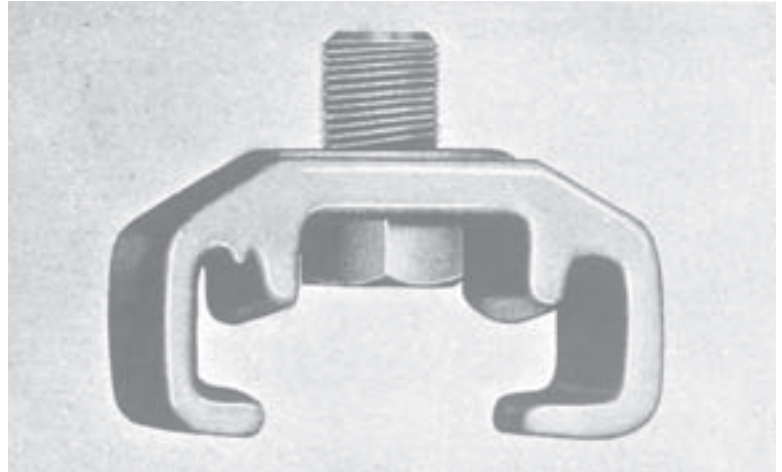

System	Hanger Cat. No.	A	B	C	Insulator Bolt	Maximum Support Centers Feet	Net Weight Lbs.
500-750	106125	1 1/2	5/8	1 1/2	3/8-16 UNC	6	.17
1000-1250	106126	2	1 1/16	2 7/8	5/8-11 UNC	12	.31
1500-1750						14	
2000	106127	3	1 3/8	4 5/8	5/8-11 UNC	16	1.2
2500						18	
3000						20	

Splice Joint Assembly

The splice joint assembly connects and aligns adjoining conductor sections without drilling or welding. Simplicity of the assembly requires only standard hex wrenches. Bolts secure a Belleville-spring-type, aluminum plate which insures the electrical connection.

The aluminum splice joint has an electrical efficiency of greater than 100% when compared by the resistance test method (NEMA SG1-5.02) to an equal length of conductor.

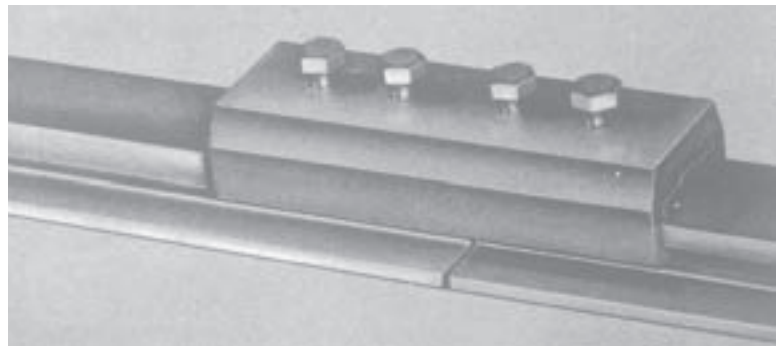

System	Splice Joint Cat. No.	A	B	C	D	Number of Bolts	Rating Amperes 30°C. Over 40°C.	Net Weight Lbs.
500-750	106130	6	5/8	1 1/2	7/16	4	750	.59
1000-1250	106131	8	1 1/16	2 7/8	5/8	4	1250	2.25
1500-1750	106132	10	1 1/16	2 7/8	5/8	4	1750	2.81
2000	106133	11	1 3/8	4 1/2	1	6	2000	7.94
2500	106134	14	1 3/8	4 1/2	1	6	2500	9.94
3000	106135	18	1 3/8	4 1/2	1	8	3000	12.86

Anchor Assembly

Anchor assemblies are employed at one or more points in the system to secure the conductor to a fixed point from which the conductor can expand or contract through the hangers.

The assembly consists of an aluminum extrusion with bolts that securely clamp to the conductor.

An anchor assembly replaces a hanger in the system and requires two mounting insulators.

Insulator selection depends on the operating voltage of the system and the anchor bolt size.

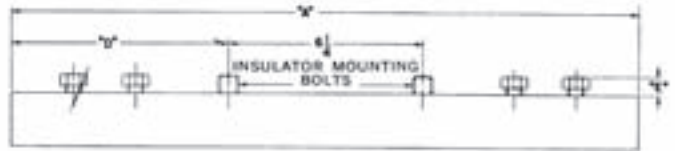
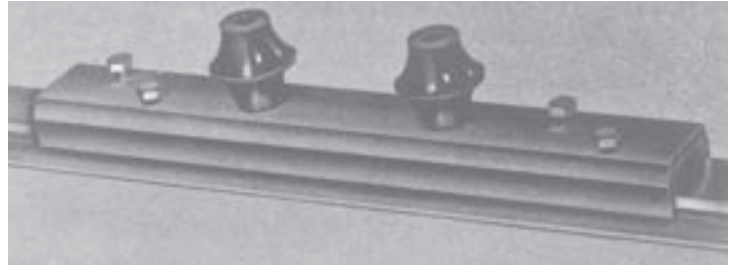
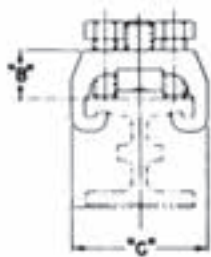

System	Anchor Cat. No.	A	B	C	D	E	Insulator Bolt	Net Weight Lbs.
500-750	106140	12 1/2	5/8	1 1/2	3 1/8	7/16	3/8-16 UNC	1.15
1000-1750	106141	21	1 1/16	2 7/8	7 3/8	5/8	5/8-11 UNC	5.27
2000-3000	106142	25	1 3/8	4 1/2	9 3/8	1	5/8-11 UNC	15.12

Isolating Joint Assembly

The Isolating Joint Assembly is used to insulate adjacent conductor sections from each other without interfering with collector travel. It allows portions of the system to be electrically disconnected while operations continue on other live sections. At installations where more than one crane will be operated on a single conductor system, the isolating joint is used to create maintenance and repair bays. The isolating joint may be inserted at any point on the system in place of a standard splice joint assembly. When installed, it assures correct alignment between adjacent conductors. There are two methods of feeding the conductor system at isolation joints. (See Diagram).

Each side can be fed individually through adequate safety switches or the isolation joint can be by-passed with the use of feeder assemblies and a suitable disconnect switch.

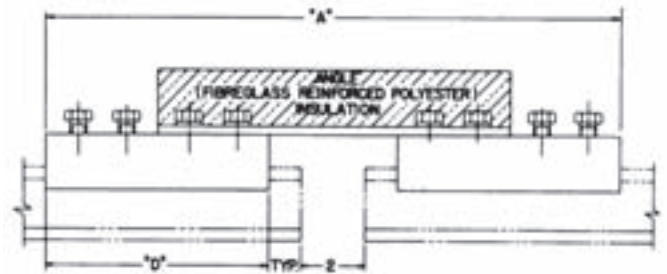
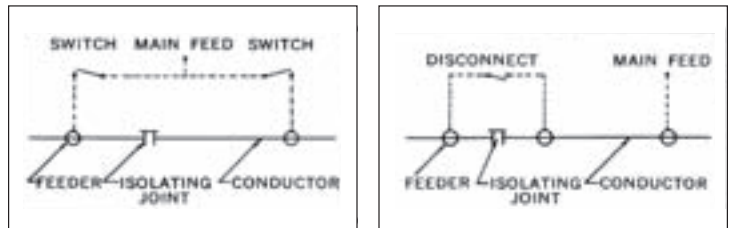
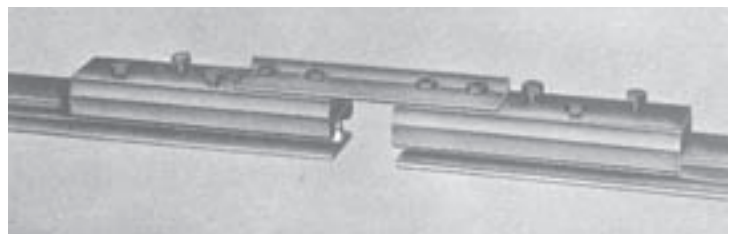
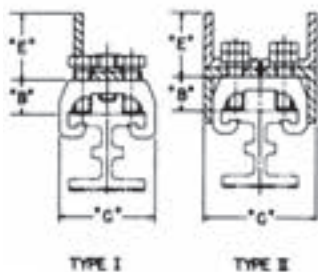

System	Isolating Joint Cat. No.	Type	A	B	C	D	E	Net Weight Lbs.
500-750	106145	I	18	5/8	1 1/2	7	1 1/2	1.60
1000-1750	106146	I	21	1 1/16	2 7/8	8 1/2	2	4.68
2000-3000	106147	II	25	1 3/8	5	10 1/2	2 1/4	14.25

Fixed Expansion Joint

Fixed expansion joints are sometimes necessary to accommodate building or supports structure expansion. Normal indoor installations do not require expansion joints if temperature ranges do not exceed 80°F. Extreme variations in temperature will require expansion joints on longer systems. Electrical continuity is maintained through flexible copper shunts. Shunts are separated from the aluminum by use of bi-metal plates. Conductor gap setting is based on both the ambient temperature at the time of installation and the expected temperature variation to which the system will be exposed. Two insulators are required with each fixed expansion joint.

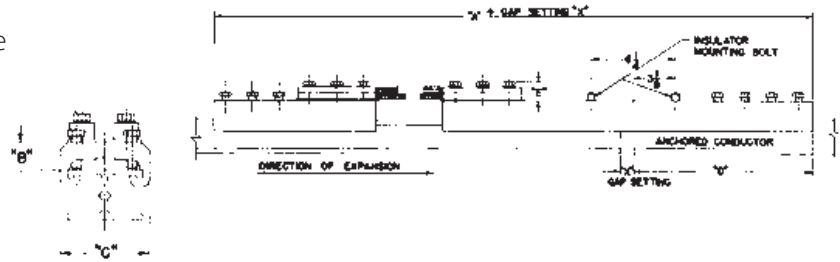
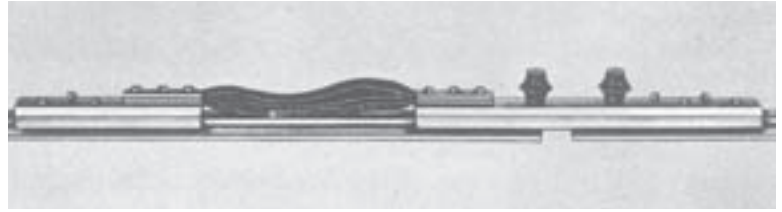

System	Expansion Joint Cat. No	Maximum Expansion (X) inches	A	B	C	D	E	Insulator Bolt	Rating Amperes 30°C Over 40°C	Recommended Max. System Length				Net Wt Lbs.
										Ft. Center Anchor		Segment Between Expansion Joints		
										Indoor	Outdoor	Indoor	Outdoor	
500-750	106150	1 1/2	40 5/8	5/8	1 1/2	11 3/8	3/4	3/8-16 UNC	750	Not required for normal installation	500	---	100	3.89
1000-1250	106151	2 1/2	57	1 1/16	2 7/8	14 1/2	1 1/8	5/8-11 UNC	1250		1000	---	250	18.56
1500-1750	106152	2 1/2	57	1 1/16	2 7/8	14 1/2	1 1/8	5/8-11 UNC	1750		1500	---	250	19.96
2000-2500	106153	2 1/2	63	1 3/8	4 1/2	18 1/2	1 1/8	5/8-11 UNC	2500		2000	---	400	45.91
3000	106154	2 1/2	63	1 3/8	4 1/2	18 1/2	1 3/8	5/8-11 UNC	3000		2500	---	400	48.71

Floating Expansion Joint

Floating Expansion Joints are used only when the gap setting exceeds the fixed expansion joint capability. Electrical continuity is maintained through flexible copper shunts. Shunts are separated from the aluminum by use of bi-metal plates.

Conductor gap setting is based on both the ambient temperature at the time of installation and the expected temperature variation to which the system will be exposed. *NO insulators are required.*

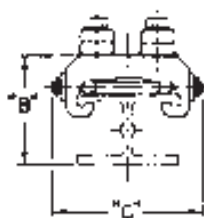
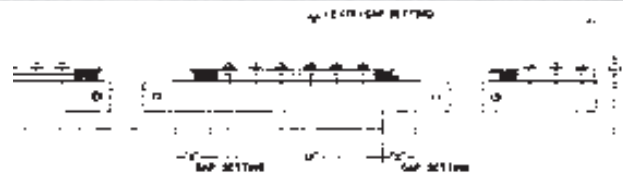

System	Expansion Joint Cat. No	Maximum Expansion (2X) inches	A	B	C	D	Rating Amperes 30°C Over 40°C	Net Wt Lbs.
500	106160	3	38	1 5/8	2 1/4	3/4	500	7.30
750	106161	3	38	1 7/8	2 1/4	3/4	750	7.59
1000	106162	5	56	2 9/16	3 13/16	1 1/8	1000	33.34
1250	106163	5	56	2 13/16	3 13/16	1 1/8	1250	33.78
1500	106164	5	56	3 1/16	3 13/16	1 3/8	1500	37.02
1750	106165	5	56	3 5/16	3 13/16	1 3/8	1750	37.46
2000	106166	5	56	3 7/8	5 1/2	1 1/8	2000	66.08
2500	106167	5	56	4 1/8	5 1/2	1 1/8	2500	67.40
3000	106168	5	56	4 3/8	5 1/2	1 3/8	3000	74.61

Feeder Assembly

The Feeder Assembly provides the electrical connection from the power source to the conductor system. It may be located at any point within the system.

Long systems should locate the feeder near the center of the system. Feeders should be located no closer than 6 inches from the nearest component. Provisions are made for 1, 2, 3 or 4 feeder lugs. Lugs are *not* furnished with the assembly except by request. Feeders are tapped for standard NEMA type lugs. Bi-metal plates are provided to prevent electrolytic action between aluminum and the bronze or copper lug.

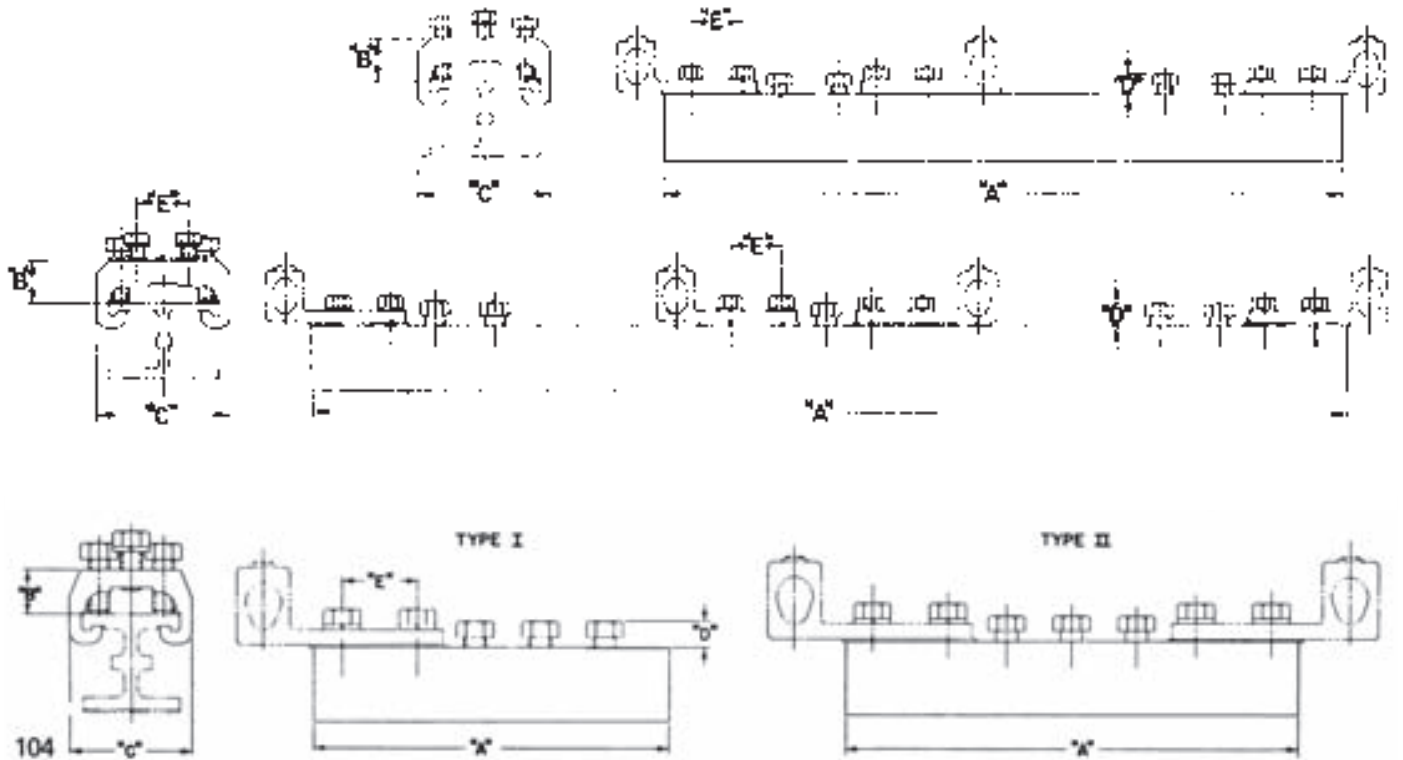
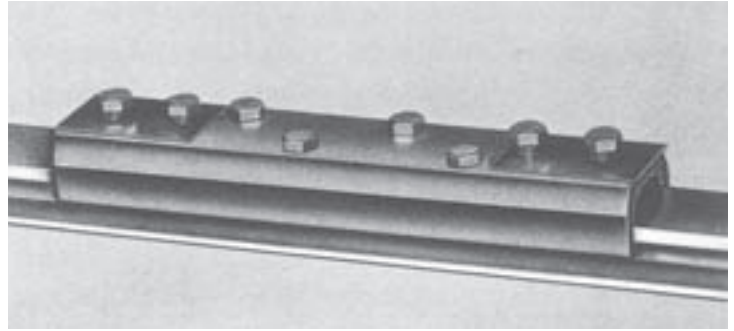

System	Feeder Cat. No	Type	A	B	C	D	Feeder Lug Provision			Rating Amperes 30°C Over 40°C	Net Wt Lbs.
							Quantity	Bolt Size	Bolt Spacing "E"		
500-750	106170	I	8 ¹ / ₄	5 ⁵ / ₈	1 ¹ / ₂	7 ⁷ / ₁₆	1	1/2-13 UNC	1 ³ / ₄	500	.82
	106171	II	10 ¹ / ₂				2			750	1.26
1000-1750	106172	II	14	1 ¹ / ₁₆	2 ⁷ / ₈	5 ⁵ / ₈	2			1 ³ / ₄	1000
	106173	III	23	1 ¹ / ₁₆	2 ⁷ / ₈	5 ⁵ / ₈	3	1 ³ / ₄	1750	5.70	
2000-3000	106174	III	23 ³ / ₄	1 ³ / ₈	4 ¹ / ₂	1	3	1/2-13 UNC	1 ³ / ₄	3000	14.90
	106175	IV	35	1 ³ / ₈	4 ¹ / ₂	1	4				21.50

Collector Assembly

The collector assembly is used to pick up current from the conductor and transmit it to the crane. The contact shoe, which is in contact with the conductor, is made of a metal graphite composition which insures long shoe life without affecting conductor wear. The collector arms are of cast aluminum, and the assembly has provisions for varying the contact shoe pressure by means of an adjustable spring. The arm assembly provides for vertical misalignment while the shoe width accommodates for horizontal misalignment. The entire collector assembly can be mounted in any plane. Under or side running are the most common mounting positions.

Collectors can be provided with one, two, or four arms depending on the current requirements. Two insulators must be used with the one and two arm collector while four are required for the four arm unit. Normally, the same insulator used for the hangers would be employed.

Collector arms, sub-assemblies, contact shoes, and other components are readily available and can be ordered separately, from the entire collector assembly.

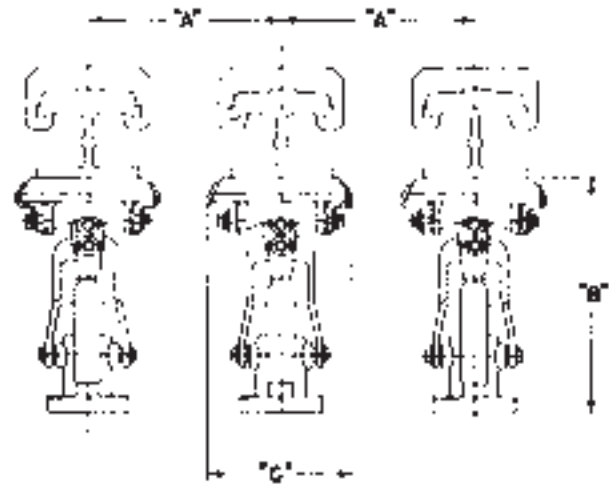
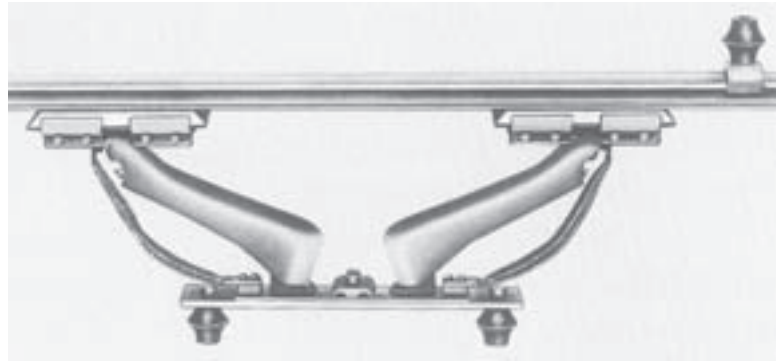

System	Collector Cat. No.	Rating Amperes 30°C Over 40°C	No. of Arms	A Min.	B	C	Net Weight Lbs.
500-1750	99832	250	1	6 1/2	8 5/8	5 7/16	28
	99668	600	2				57
	99833	1200	4				116
2000-3000	106391	500	1	8	10	6 7/16	30
	106392	1000	2				60
	106394	2000	4				125

Current Rating		System Series					
		500 - 1750			2000 - 3000		
		Single Arm (1)	Double Arm (2)	Four Arm (4)	Single Arm (1)	Double Arm (2)	Four Arm (4)
		Catalog Number	99832	99668	99833	106391	106392
Continuous Duty Amperes	30°C	250	600	1200	500	1000	2000
	40°C	350	750	1500	650	1300	2800
	60°C	1000	2200	4400	1200	2400	5000
	40°C Ambient 70°C	1200	2500	5000	1500	3000	6000
Intermittent Duty Amperes	1 Min - On	1050	2200	4400	1850	3600	7500
	1 Min - Off						
	5 Min - On						
	5 Min - Off						
40°C Rise Over 15 Min - On	950	2000	4000	1700	3200	7000	
	15 Min - On	600	1400	2800	1200	3000	6000
	15 Min - Off						

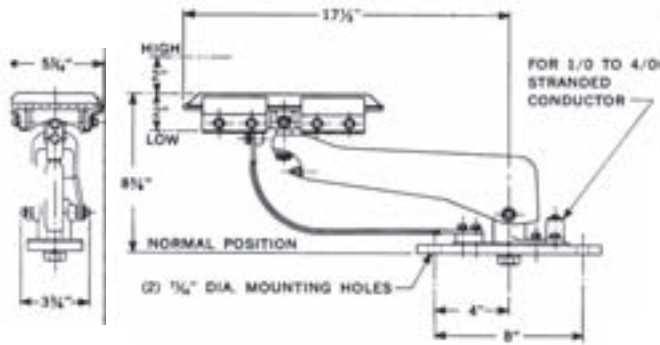

No. 99832

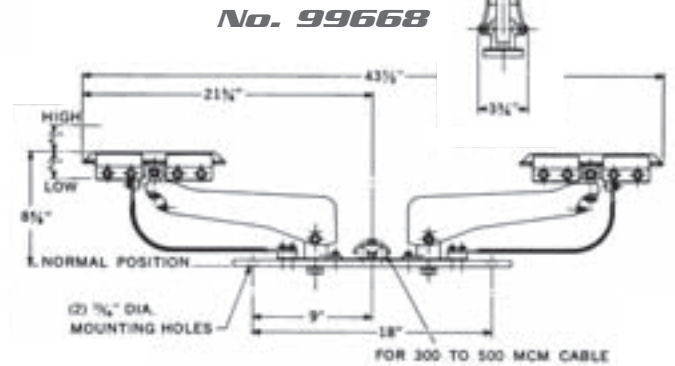

No. 99668

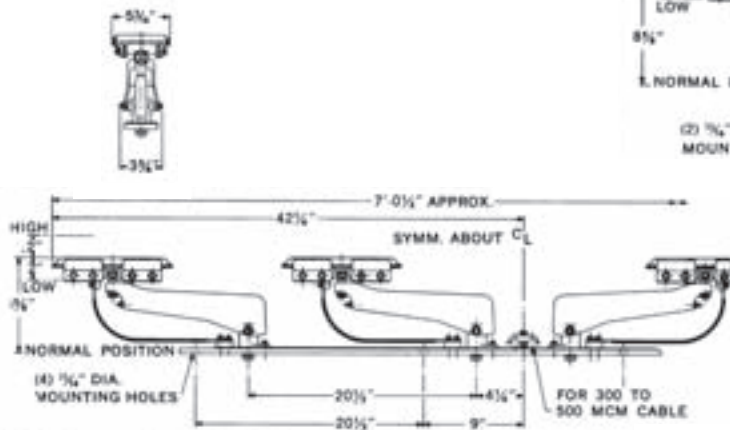

No. 99833

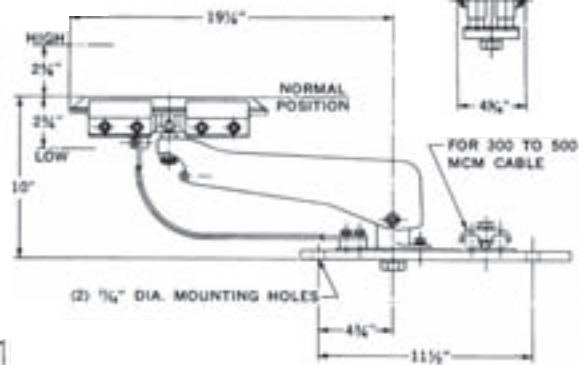

No. 106391

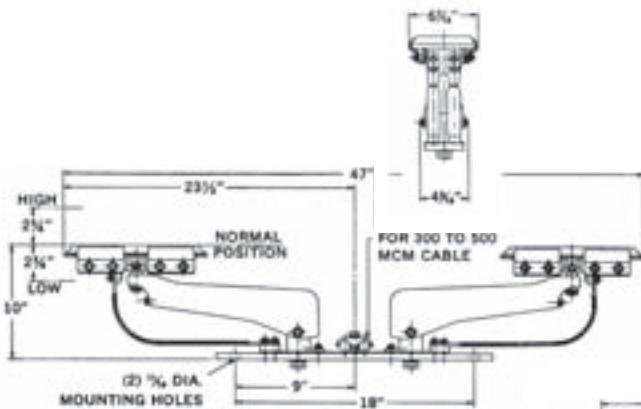

No. 106392

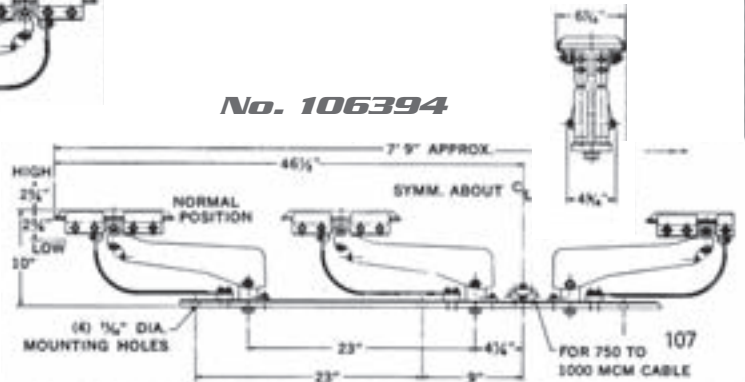

No. 106394











System Layout

The first step in preparing a system layout is to select the proper amperage conductor rating required for the installation. Once the conductor size has been selected the hanger support-centers for that particular size conductor may be selected from the chart shown with the hanger assembly on Page 3. In order to determine if an expansion joint is required, refer to the fixed expansion joint chart. In the majority of installations none is required. This is due to the advanced design of the nylon coated hanger. In the event a building expansion joint occurs near mid-point in the system, a floating expansion joint assembly should be considered. Where no expansion joints are required, the system should be anchored approximately in the center. Anchor assemblies are shown on Page 4. The feeder assembly, if possible, should be

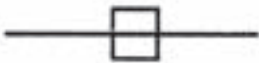
located near the center of the system. This reduces the effective systems length "L" which is used in the formula to determine the proper conductor amperage rating. Feeders with provisions for one to four lugs may be selected from the feeder assemblies on Page 6.

Careful attention must be given to mechanical clearances between components. All splice joints, expansion joints feeders, and isolation joints must be kept at a minimum of six (6) inches away from the nearest insulated hanger to insure free sliding of the conductor through the hanger.

The following symbols and example layouts are intended for a guide in preparing a layout. However, upon request Trans Tech will prepare an application layout to fit your requirements.

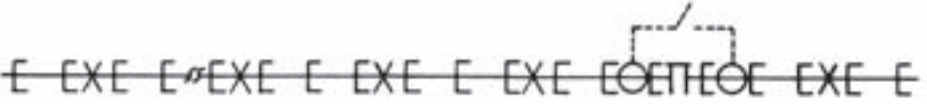
Conductor 	Feeder 	Floating Expansion Joint 
Hanger 	Anchor 	
Conductor 	Conductor 	Conductor 
SYSTEM A — No Expansion Joint — Center Anchored		
SYSTEM B — Floating Expansion Joint		
SYSTEM C — Expansion Joint (Fixed)		
SYSTEM D — Isolating Joint		

TECHNICAL DATA

CONDUCTOR SIZE CALCULATION

There are two accepted methods of determining the maximum ampere demand of one or more cranes on a single runway.

Method A

Maximum load equals the sum of all main and auxiliary hoist H.P. plus one-half (1/2) the sum of all bridge motor and trolley H.P.

Method B

Maximum load equals one-half (1/2) the sum of all motor and accessory H.P.

CALCULATION

Load H.P. (Method A or B) x amperes per H.P. (Table A) = maximum ampere demand.

Maximum ampere demand x crane factor (Table C) = adjusted maximum ampere demand.

VOLTAGE DROP CALCULATION

Symbols

VL = Line Voltage at Feeder (Source).

VD = Voltage Drop.

I = Load Amperes.

L = Effective System Length in Feet. Maximum distance from feeder to end of system.

RDC = D. C. Resistance-ohms/1000 feet.

K = Voltage Drop Multiplier (Table B). A factor derived from tests which accounts for variables such as A. C. resistance, inductive reactance, power factor, phase spacing, and conductor shape factors.

Formulas

Direct Current

$$VD = \frac{ILR_{DC}}{500}$$

Alternating Current - Three Phase

(80 percent Power Factor-Flat Spacing)

$$VD = I L K \text{ (Line to Line*)}$$

*For Line to Neutral Voltage Drop divide by 1.73.

Voltage Regulation

$$\% \text{ Regulation} = \frac{VD}{VL - VD} \times 100$$

Example

Length of runway, 400 feet, operating on 440 volts, 3 phase, 60 cycle, phase spacing 5 inches, feeder location-center of runway, one crane on runway. By Method "A," the maximum ampere demand would be calculated as follows:

	ACTUAL H.P.	CALCULATED H.P.
Main Hoist	200	200
Auxiliary Hoist	250	250
Bridge (2 motors at 150 each)	300	150
Trolley	60	<u>30</u>
		Total 630 H.P.

From Table A multiplier is 1.5. 1.5 x 630 H.P. = 945 maximum ampere demand. Based on a 30°C rise over 40°C ambient, you could select the 1000 aluminum H-Bar series for this application.

From Table B, the 1000 Series with a 5 inch phase spacing has a K multiplier of 67.22 x 10⁻⁶ - therefore:

$$VD \text{ (Voltage Drop)} = I \times L \times K$$

$$VD = 945 \times 200 \times (67.22) (10^{-6})$$

$$VD = 12.7 \text{ volts}$$

$$\% \text{ Regulation} = \frac{VD}{VL - VD} \times 100$$

$$\text{Regulation} = \frac{12.7}{440 - 12.7} \times 100 = 2.9\%$$

TABLE A
Amperes Per Horsepower Conversion

Current	Voltage	Multiplier*
D.C.	115	8
	230	4
	600	1.6
A.C. (3 ϕ)	110	7.0
	220	3.0
	440	1.5
	550	1.2
	2300	0.25
A.C. (2 ϕ)	110	6.0
	220	2.6
	440	1.3
	550	1.1
	2300	0.21

*Average conversion factors calculated from National Electric Code Full Load Current Motor Charts. Motors built for especially low speeds or high torques may require more running current. In which case, name-plate or design current ratings should be used.

TABLE C
CRANE FACTOR (C²)

Current	Multiplier*
1	1
2	0.95
3	0.91
4	0.87
5	0.84

*In the event there are two or more cranes operating on the same load side of the feeder, the multiplying factors shown in Table C would be applied to the maximum ampere demand calculated by Method A or B.

TABLE B

H-Bar Conductor Series	"K"-Voltage Loss Multiplier X 10 ⁻⁶												
	Conductor Phase Spacing — Inches												
	3	3 1/2	4	4 1/2	5	5 1/2	6	6 1/2	7	7 1/2	8	9	10
500	86.10	89.70	92.80	95.49	97.96	1000.2	102.3	104.1	106.0	107.5	109.0	111.8	114.2
750	68.77	72.42	75.18	78.32	80.77	83.03	85.08	86.78	88.69	90.29	91.83	94.60	97.10
1000			58.62	64.74	67.22	69.46	71.48	73.42	74.97	76.77	78.25	81.02	83.48
1250			54.73	57.45	59.92	62.16	64.20	66.14	67.82	69.48	70.95	73.73	76.14
1500			49.54	52.29	54.76	57.00	59.05	60.94	62.66	64.26	65.80	68.56	71.73
1750			45.76	48.35	50.99	53.23	55.28	57.16	58.90	60.52	62.04	64.80	67.15
2000						48.72	50.76	52.09	54.40	55.99	57.52	60.29	63.32
2500						43.61	45.65	47.53	49.27	50.90	52.40	55.17	57.63
3000						40.06	42.16	44.04	45.77	47.41	48.73	51.68	54.15

Expansion Gap Setting Guide

The following chart is provided as a means of determining the initial expansion gap setting, depending upon application ambient conditions.

The chart should be used according to the following procedure:

- (a) Select system under consideration and respective curve line, indicating maximum gap opening.
- (b) Determine local ambient temperature range: Example -20 to 100°F.
- (c) Starting at point X on A scale, write in the ambient range starting at highest expected ambient and decrease in 10 degree increments to the lowest expected ambient.
- (d) Determine ambient temperature at time of gap setting. From the existing ambient temperature, A scale, read across to the appropriate curve and down to the gap setting. Adjust conductor accordingly.

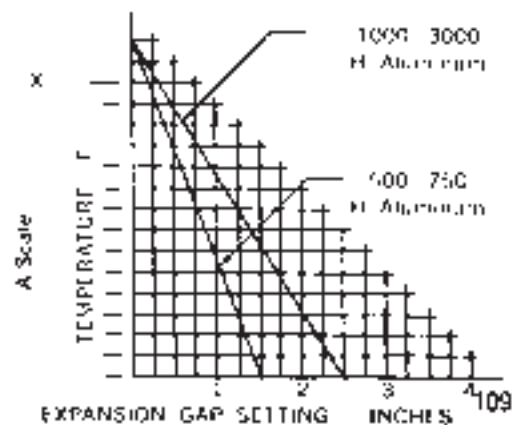

GENERAL SPECIFICATIONS

The conductor-collector system shall be of the H-Bar Aluminum Series as manufactured by Trans Tech.

Each system shall consist of necessary conductor sections, hanger supports, insulators, anchor supports, expansion joints, collectors, and/or special components as determined from plans and specifications.

The conductor section shall be one-piece aluminum of H-Bar configuration with a flat contact surface. The conductor aluminum alloy shall have a minimum conductivity of 56% IACS and a current carrying capacity of (500) (750) (1000) (1250) (1500) (1750) (2000) (2500) (3000) amperes based on a 30°C rise over 40°C ambient when operating in still, but unconfined air. The conductor shall have sufficient thermal capacity to withstand a 300% overload for intermittent duty cycles.

The conductor hangers shall be cast of high strength aluminum alloy. The hanger will be nylon coated to provide free conductor movement through the hanger to accommodate expansion or contraction of the conductor rail. Splice joints, anchors, feeders, and expansion joints shall be provided as required. These elements shall be manufactured from the same aluminum alloy as the conductor rail. The design shall be such that only bolting to the conductor is required; no drilling or welding of the rail at erection shall be necessary.

The splice joints, feeders, and expansion joints shall have an electrical efficiency of greater than 100 percent when compared by the resistance test method (NEMA SG 1-5.02) to an equal length of conductor.

The temperature rise of the accessory components shall not exceed the 30°C rise of the conductor with which it is intended.

Insulators

The insulators shall be of the Red-Poly Type, molded from fiberglass reinforced polyester material, as manufactured by Trans Tech. The insulator shall have a dew flashover strength when tested per ABA Specification C29.1 of at least four (4) times normal system voltage.

The basic insulator material shall exhibit the following minimum performance levels when tested in accordance with American Society of Testing Materials Specifications. (ASTM)

Property	Minimum	ASTM No.
Dielectric Strength	400VPM	D149
Arc Track Resistance	180 Seconds	D495
Flame Retardance	Self-Exting.	D635
Heat Distortion Temp. @ 264 psi	400°F	D648
Dissipation Factor, 60N	.035	D150
Impact Strength, Ft-Lbs.	4	D256
Flexural Strength, psi	16,000	D790

Collectors

The collectors shall have a current carrying capacity of (250) (500) (600) (1000) (1200) (2000) amperes based on a 30°C rise over a 40°C ambient when operated in still, but unconfined air. The collectors shall have sufficient thermal capacity to withstand a 300% overload for intermittent duty cycles. The collectors shall incorporate means of adjusting the contact pressure. The collector shall consist of a high strength aluminum arm which covers the collector spring.

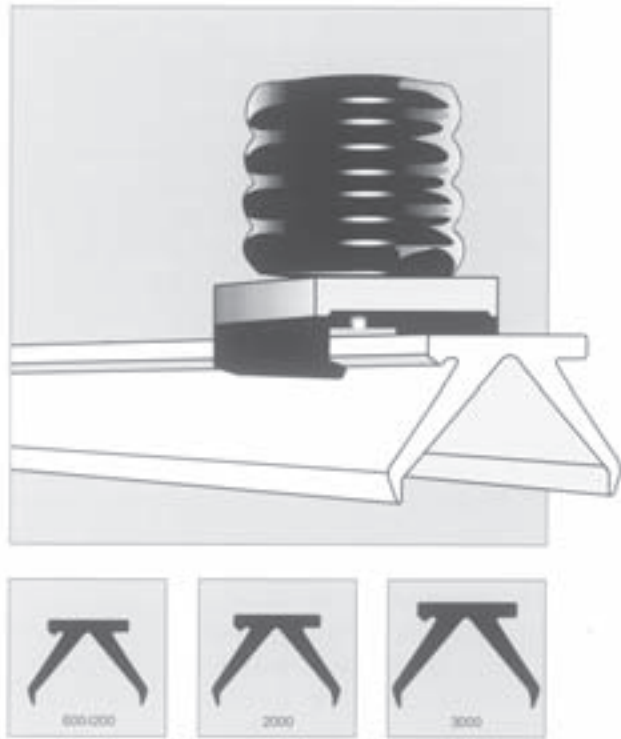

System Features

Inverted V-Bar conductor systems were designed to provide an efficient and economical means to supply power to all types of cranes, or other movable equipment requiring a constant source of electrical energy.

Inverted V-Bar is particularly adaptable in areas of high contamination and outdoor installations where the system is subjected to icing conditions. In addition, the "V" configuration acts as a guide for the collector shoe; thereby compensating for minor conductor misalignment on long installations.

Aluminum V-Bar Systems come in standard ratings of 600, 1200, 2000, and 3000 amperes. Higher ratings in aluminum or bronze and copper systems are available upon request.

The inverted V offers simplicity of erection in that no field welding, drilling, or cutting is required. Assembly is accomplished by means of standard wrenches as hex head bolts are used on all assemblies. Conductors are furnished in factory pre-cut lengths to fit your requirements. Installation and application drawings engineered for your particular requirements are furnished with each system locating the various components for erection.

A variety of standard metal enclosure designs are available for personnel protection. In the event modifications are required, a custom designed enclosure to meet your needs can be developed.

V-Bar is another of the TransTech family of conductor systems available for current collecting applications.

Our sales personnel and engineering staff are available for aiding in the selection of the most economical system for your present and future requirements.

V-Bar

Standard Components - Aluminum V-Bar Conductor Systems				
Component	System Component Catalog Number			
	600 V-Bar	1200 V-Bar	2000 V-Bar	3000 V-Bar
Conductor*	98724-L*	98724-L*	94801-L*	93531-L*
Hanger with 5/8" Bolt	11455801	11455801	11468601	11449901
Splice Joint	95913	95912	94810	93536
Anchor	96426	96426	94807	96350
Feeder	96374	105454	96412	96367
Fixed Expansion Joint R.H.	96669	96497	96492	96493
Fixed Expansion Joint L.H.	96386	95930	94813	96303
Floating Assembly Joint	105547	99167	97545	106321
Isolating Joint	99910	99910	97963	109021
Collectors - Single Arm	99572	99572	99305	99305
Collectors - Double Arm	99573	99573	98986	98986
Collectors - Four Arm	---	99574	99542	99542

*“L” designates conductor length in feet. Standard length is 30’.
 An application of dry lubricant, Part No. 91592, is required on the conductor contact surface prior to use.
 Oxide inhibiting paste, Part No. 90918, is required on all splice joints, feeders, and expansion joints.

Conductor

The V-Bar Conductor is designed for main runway or cross-travel applications. The recommended mounting is in the inverted V position (^) with the collectors underrunning. The conductors are normally mounted horizontally; however they can be vertically stacked. Phase spacing depends on conductor rating and collector selection.

The conductor is extruded from high conductivity aluminum alloy in maximum 30 foot lengths. Shorter lengths are available (5 foot minimum) in one foot increments to coincide with runway length requirements.

A keying feature incorporated into the conductor configuration assures that all components are properly installed.

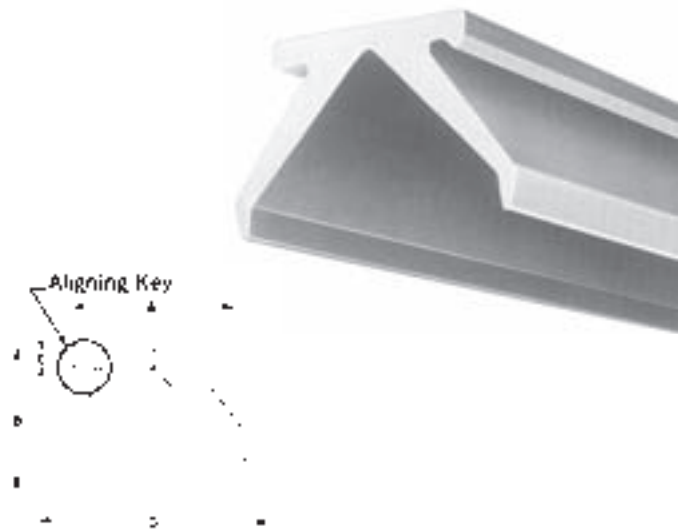

System Ampere Rating*	Conductor Cat. No.	A	B	C	D	Cross Sectional Area		Weight Lbs./Ft.	DC Resistance Ohms/1000 ft. at 20° C.	AC Resistance Ohms/1000 ft. at 20° C.	Self Geometric Distance d s - Inches
						Sq. Inches	CMx 10 ⁶				
600	98724-L	2 3/8"	2 1/16"	1/4"	3 3/8"	2.1	2.7	2.45	0.00705	0.0100	1.218
1200	98724-L	2 3/8"	2 1/16"	1/4"	3 3/8"	2.1	2.7	2.45	0.00705	0.0100	1.218
2000	94801-L	3"	2 1/8"	7/16"	3 5/8"	3.3	4.2	3.84	0.00452	0.00724	1.377
3000	93531-L	3 1/2"	3"	9/16"	5 1/8"	4.9	6.2	5.7	0.00305	0.00630	1.700
6000	Contact TransTech										

*Ampere rating based on 30°C rise over a 40° ambient.

Insulated V-Bar Systems

Aluminum systems, ratings 600 through 3000 amperes, are available with an extremely tough electrical grade thermoplastic red jacket suitable for indoor or outdoor installations.

The insulating jacket is normally installed during installation.

The insulation provides protection to personnel by enclosing the top and two sides of the conductor. Special covers are provided for splice joints, anchors, feeders, hangers, expansion joints, and isolating joints in order to provide a completely insulated system.



Hanger Assembly

The hanger assembly is used to support the conductor section with the aid of an insulator. The assembly consists of a molded casting with a 5/8-11 bolt for insulator mounting. Hangers are nylon coated to assure free movement of the conductor during expansion or contraction. Insulators are not furnished with the assembly.



Insulator selection depends on mounting clearances and operating voltage.

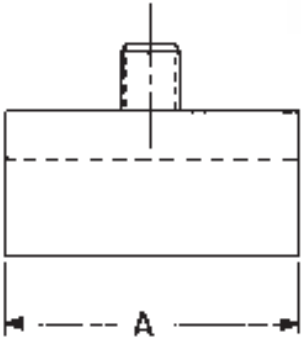
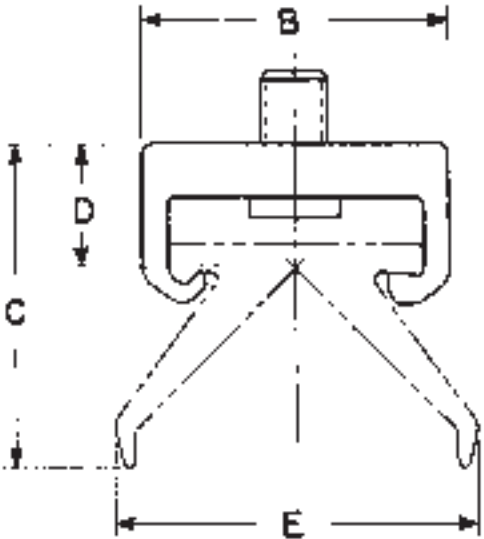

System	Hanger Cat. No.	A	B	C	D	E	Maximum Support Centers Feet	Net Weight Lbs.
600	11455801	3"	2 ⁷ / ₈ "	2 ¹⁵ / ₁₆ "	1 ¹ / ₈ "	2 ¹⁵ / ₁₆ "	12'	.9
1200	11455801	3"	2 ⁷ / ₈ "	2 ¹⁵ / ₁₆ "	1 ¹ / ₈ "	2 ¹⁵ / ₁₆ "	12'	.9
2000	11468601	3"	3 ⁵ / ₈ "	3 ⁵ / ₁₆ "	1 ⁹ / ₁₆ "	3 ⁵ / ₁₆ "	14'	1.2
3000	11449901	3"	4 ¹ / ₄ "	4 ⁹ / ₁₆ "	2 ¹ / ₁₆ "	4 ⁹ / ₁₆ "	15'	1.2

Splice Joint Assembly

The splice joint assembly connects electrically and mechanically, adjoining conductor sections without drilling or welding. The assembly consists of an extruded section containing bolts and a Belleville spring-type plate which insures positive electrical connection. All splice joints have a current capacity of greater than 100% when compared by the resistance test method (NEMA SGI-5.02) to an equal length of conductor.

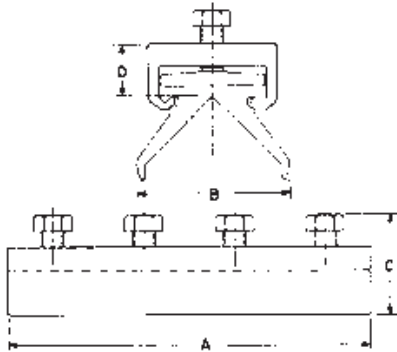
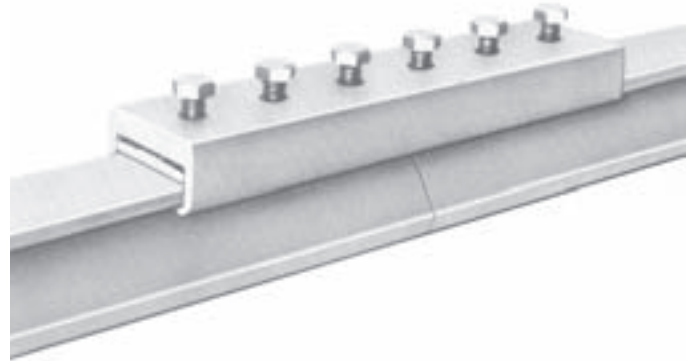

System	Splice Joint Cat. No.	A	B	C	D	Number of Bolts	Rating Amperes 30° C. Over 40° C.	Net Weight Lbs.
600	95913	8"	3 ³ / ₈ "	2 ¹ / ₄ "	1 ¹ / ₈ "	4	600	2.0
1200	95912	12"	3 ³ / ₈ "	2 ¹ / ₄ "	1 ¹ / ₈ "	6	1200	3.1
2000	94810	16"	3 ⁵ / ₈ "	2 ³ / ₄ "	1 ⁹ / ₁₆ "	8	2000	7.8
3000	93536	18"	5 ¹ / ₈ "	3 ⁹ / ₁₆ "	2 ¹ / ₁₆ "	8	3000	10.9

Anchor Assemblies

Anchor assemblies are normally employed at one point in the system to provide a fixed point from which the conductor can expand or contract through the hangers. When expansion joints are employed additional anchors may be required.



The assembly consists of an extrusion with bolts that securely clamp it to the conductor and two studs for insulator mounting. An anchor is used in place of a hanger and requires two insulators which are not furnished with the assembly. Insulators should have the same height as the one used with the hanger assembly.

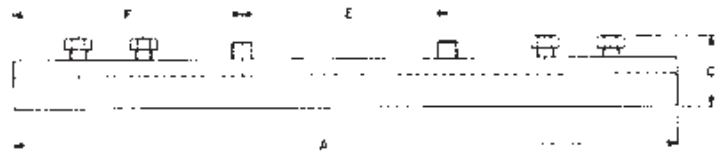

Insulator selection depends on the operating voltage of the system.



System	Anchor Cat. No.	A	B	C	D	E	F	Insulator Bolt	Net Weight Lbs.
600	96426	20 ¹ / ₄ "	3 ³ / ₈ "	2 ³ / ₁₆ "	1 ¹ / ₈ "	6 ¹ / ₄ "	7"	5/8"-11 UNC	4.3
1200	96426	20 ¹ / ₄ "	3 ³ / ₈ "	2 ³ / ₁₆ "	1 ¹ / ₈ "	6 ¹ / ₄ "	7"	5/8"-11 UNC	4.3
2000	94807	22"	3 ⁵ / ₈ "	2 ⁷ / ₈ "	1 ⁹ / ₁₆ "	6 ¹ / ₄ "	7 ⁷ / ₈ "	5/8"-11 UNC	7.5
3000	96350	20"	5 ¹ / ₈ "	3 ⁹ / ₁₆ "	2 ¹ / ₁₆ "	6 ¹ / ₄ "	6 ⁷ / ₈ "	5/8"-11 UNC	9.8

Isolating Joint Assembly

The isolating joint assembly is used to insulate adjacent conductor sections from each other without interfering with collector travel. It allows portions of the system to be electrically disconnected while operations continue on other live sections. At installations where more than one crane will be operated on a single conductor system, the isolating joint is used to create maintenance and repair bays. The isolating joint may be inserted at any point on the system in place of a standard splice joint assembly. When installed, it assures correct alignment between adjacent conductors. There are two methods of feeding the conductor system at isolation joints. (See Diagram.)

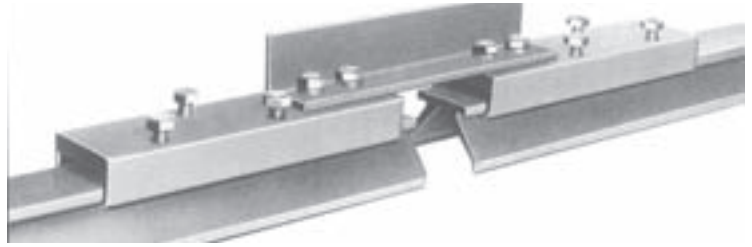

Each side can be fed individually through adequate safety switches or the isolation joint can be by-passed with the use of feeder assemblies and a suitable disconnect switch.

System	Isolating Joint Cat. No.	A	B	C	D	E	F	Net Weight Lbs.
600	99910	25"	3 ³ / ₈ "	3 ²⁹ / ₆₄ "	1 ¹ / ₈ "	10 ¹ / ₂ "	4"	5.0
1200	99910	25"	3 ³ / ₈ "	3 ²⁹ / ₆₄ "	1 ¹ / ₈ "	10 ¹ / ₂ "	4"	5.0
2000	97963	29"	3 ⁵ / ₈ "	4 ¹ / ₃₂ "	1 ⁹ / ₁₆ "	12 ¹ / ₂ "	4"	11.1
3000	109021	29"	5 ¹ / ₈ "	5 ¹ / ₁₆ "	2 ¹ / ₁₆ "	12 ¹ / ₂ "	4"	14.5

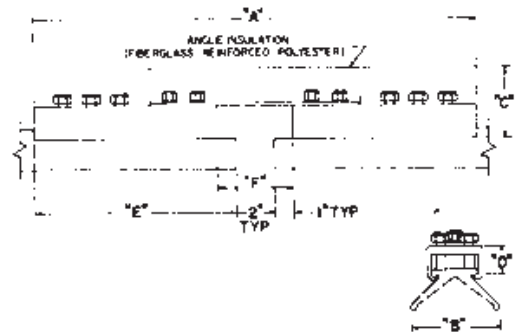
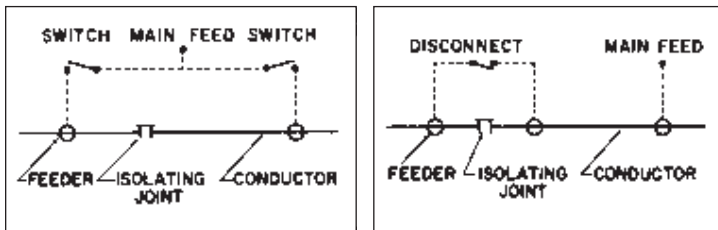

Floating Expansion Joint

Floating expansion joints are used only when the expected expansion exceeds the fixed expansion joint capability.



The assembly is normally installed between anchor assemblies across a building expansion joint.

The assembly consists of three extruded sections, one short length of conductor, flexible copper shunts, bi-metal plates, connecting links, and bolts. No insulators are required.

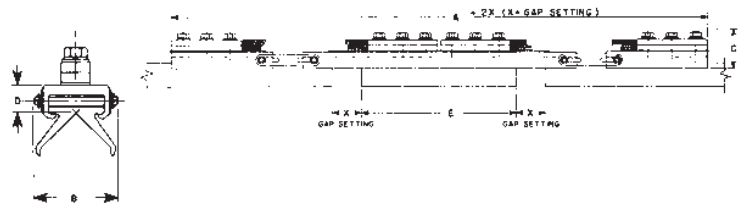

Conductor gap setting is based on both the ambient temperature at the time of installation and the expected temperature variation to which the system will be exposed.

System	Expansion Joint Cat. No	Maximum Expansion (2X) inches	A	B	C	D	E	Rating Amperes 30°C Over 40°C	Net Wt Lbs.
600	105547	5"	56"	4"	2 ⁷ / ₈ "	1 ¹ / ₈ "	12"	600	26.8
1200	99167	5"	56"	4"	3 ³ / ₈ "	1 ¹ / ₈ "	12"	1200	37.6
2000	97545	5"	56"	4 ⁷ / ₈ "	3 ⁷ / ₈ "	1 ⁹ / ₁₆ "	12"	2000	71.8
3000	106321	5"	56"	5 ¹ / ₂ "	4 ¹ / ₈ "	2 ¹ / ₁₆ "	12"	3000	84.8

Fixed Expansion Joint

Fixed expansion joints are sometimes required when the system crosses a building expansion joint or when the runway is excessively long. In addition, extreme variations in temperature along the length of the runway warrant the possible use of an expansion joint assembly. Recommended maximum system lengths with center anchor are shown in adjoining chart. Longer systems should include expansion joints.

The assembly consists of two extrusions, shunts, bolts, and two insulator mounting studs. The insulator side of the assembly is the fixed section and acts as an anchor. The other section is bolted to the conductor and with the aid of flexible copper shunts maintains electrical continuity across the conductor gap. Shunts are separated from the aluminum with bi-metal plates. Conductor gap setting is based on both the ambient temperature at the time of installation and the expected temperature variation to which the system will be exposed.

There are two assemblies—right hand and left hand. This is due to the aligning key on the conductor. Normally the key side of the conductor is located on the side nearest the centerline of the crane runway. When standing in the center of the runway facing the conductor system, a right hand assembly allows conductor expansion to the right, a left hand assembly to the left.

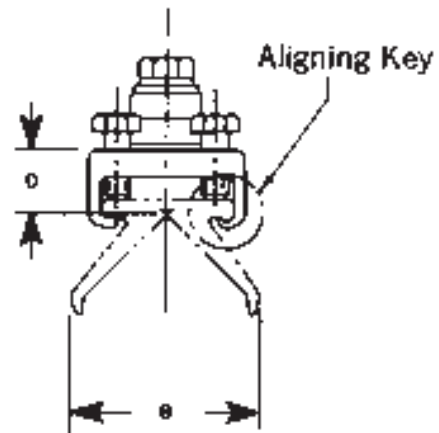
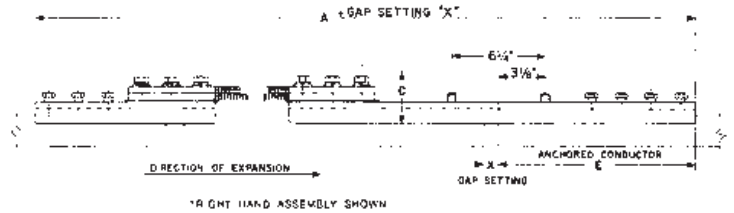

System	Expansion Joint Cat. No		Maximum Expansion (X) inches	A	B	C	D	E	Insulator Bolt		Rating Amperes 30°C Over 40°C	Recommended Max. System Length				Net Wt Lbs.
	Right Hand*	Left Hand							Ft. Center Anchor			Segment Between Expansion Joints				
									Indoor	Outdoor		Indoor	Outdoor			
600	96669	96386	2 1/2"	57"	3 3/8"	2 7/8"	1 1/8"	14 1/2"	2	5/8-11 UNC	600	600	500	300	250	14.9
1200	96497	95930	2 1/2"	57"	3 3/8"	3 3/8"	1 1/8"	14 1/2"	2	5/8-11 UNC	1200	600	500	300	250	19.3
2000	96492	94813	2 1/2"	63"	3 5/8"	3 7/8"	1 9/16"	18 1/2"	2	5/8-11 UNC	2000	800	700	400	350	39.2
3000	96493	96303	2 1/2"	63"	5 1/8"	4 1/8"	2 1/16"	18 1/2"	2	5/8-11 UNC	3000	1000	800	450	400	51.2

Feeder Assembly

The feeder provides the electrical connection from the power source to the conductor system. It may be located at any point within the system, preferably near the center. This location reduces the effective system length, which in turn reduces voltage drop. No field drilling or welding is required for installation. Feeders should be located no closer than six inches from the nearest component to prevent conductor lock-up during expansion or contraction. The feeder consists of an extrusion with bolts that clamp the assembly securely to the conductor. Bi-metal plates are provided to prevent electrolytic action when using bronze or copper lugs.

Provisions are made for one, two, or three feeder lugs. Lugs are *not* furnished with the assembly except by request at additional cost. Feeders are tapped for standard NEMA-type lugs.

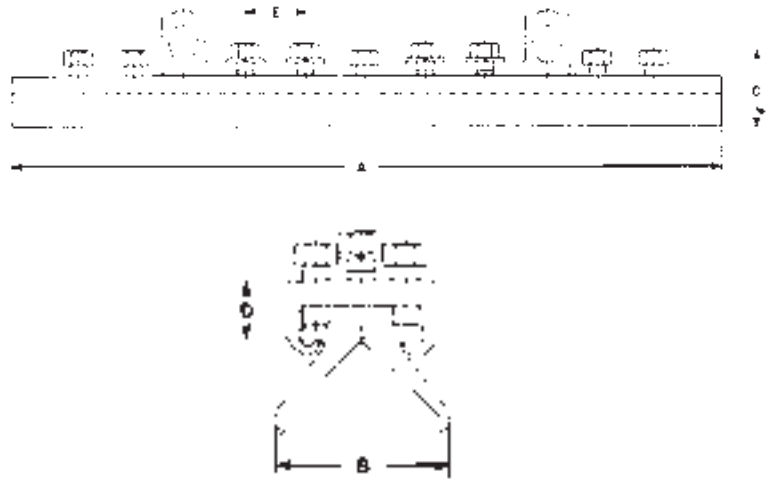

System	Feeder Cat. No	A	B	C	D	Feeder Lug Provision			Rating Amperes 30°C Over 40°C	Net Wt Lbs.
						Quantity	Bolt Size	Bolt Spacing "E"		
600	96374	16 ³ / ₄ "	3 ³ / ₈ "	2 ³ / ₁₆ "	1 ¹ / ₈ "	1	1/2-13 UNC	1 ³ / ₄ "	600	3.7
1200	105454	20 ³ / ₄ "	3 ³ / ₈ "	2 ³ / ₁₆ "	1 ¹ / ₈ "	2	1/2-13 UNC	1 ³ / ₄ "	1200	4.7
2000	96412	19 ³ / ₄ "	3 ⁵ / ₈ "	2 ⁷ / ₈ "	1 ⁹ / ₁₆ "	2	1/2-13 UNC	1 ³ / ₄ "	2000	7.1
3000	96367	20 ³ / ₄ "	5 ¹ / ₈ "	3 ¹ / ₂ "	2 ¹ / ₁₆ "	3	1/2-13 UNC	1 ³ / ₄ "	3000	10.7

Collector Assembly

The collector assembly is used to collect current from the conductor and transmit it to the equipment. Normal recommended mounting is underrunning.

The contact shoe which rides inside the "V" is made of a metal graphite composition which insures long shoe life without affecting conductor wear.

The collector arms are cast aluminum and have provisions for varying the contact shoe pressure by means of an adjustable spring. The arm assembly provides for vertical misalignment while the contact shoe assembly, mounted on a ball joint, tracks within the "V" shaped conductor compensating for horizontal misalignment.

The contact shoe assembly consists of two metal graphite contact shoes mounted on a contact shoe holder. The shoe assembly can be used on either aluminum, copper, or bronze systems.

Collectors are available with one, two, or four arms depending on the current requirements. Two mounting insulators, which are not furnished with the collector assembly, are required with the one and two arm collectors, four insulators with the four arm unit. Normally the same insulator used for the hangers would be employed.

Collector arms, sub-assemblies, contact shoes, and other components are readily available and can be ordered separately in the event replacements are required.

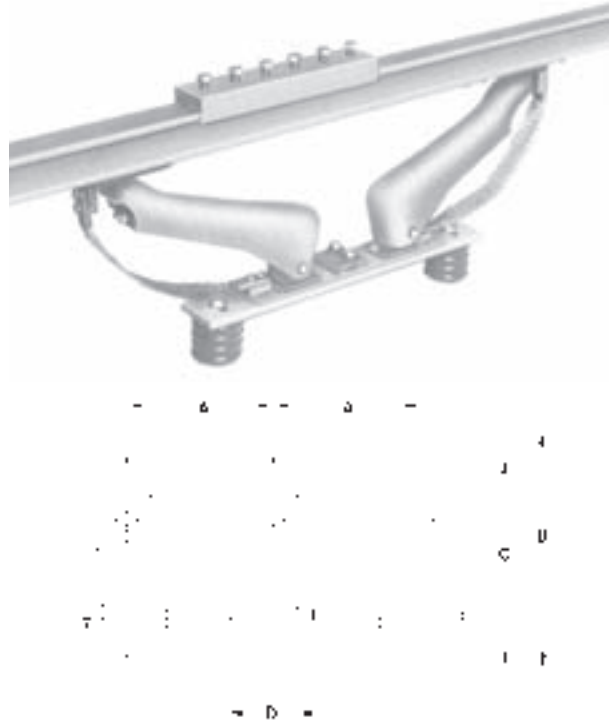

System	Collector Cat. No.	Collector Rating Amperes 30°C Over 40°C	No. of Arms	A Min.	B	C	D	Net Weight Lbs.
600 - 1200	99572	250	1	5"	10 ³ / ₁₆ "	9 ¹ / ₁₆ "	3 ³ / ₄ "	24
	99573	600	2					47
	99574	1200	4					102
2000	99305	500	1	5 ¹ / ₂ "	12 ⁷ / ₁₆ "	10 ⁷ / ₈ "	4 ³ / ₁₆ "	36
	98986	1500	2					67
	99542	3000	4					148
3000	99305	500	1	6 ¹ / ₂ "	12 ¹⁵ / ₁₆ "	10 ⁷ / ₈ "	4 ³ / ₁₆ "	36
	98986	1500	2					67
	99542	3000	4					148

Current Rating	Catalog Number		System					
			600 - 1200 V-Bar			2000 - 3000 V-Bar		
			Single Arm (1)	Double Arm (2)	Four Arm (4)	Single Arm (1)	Double Arm (2)	Four Arm (4)
			99572	99573	99574	99305	98986	99542
Continuous Duty Amperes 40°C Ambient	30°C	250	600	1200	500	1500	3000	
	40°C	350	750	1500	650	1750	3500	
Intermittent Duty Amperes 40°C Rise Over 40°C Ambient	1 Min - On	1050	2200	4400	1850	3800	7600	
	1 Min - Off							
	5 Min - On	950	2000	4000	1700	3600	7200	
	5 Min - Off							
15 Min - On	600	1400	2800	1200	3000	6000		
15 Min - Off								

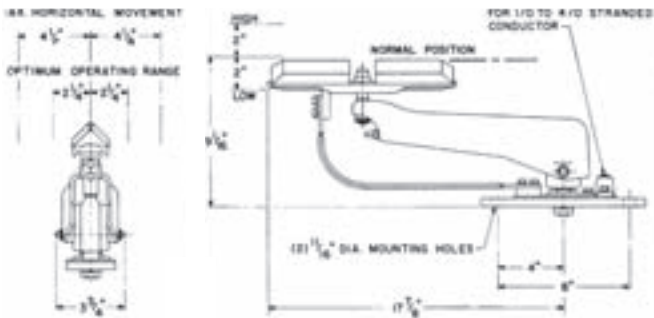

No. 99572

No. 99573

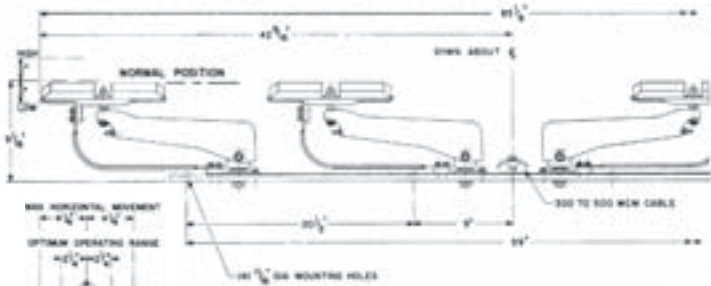
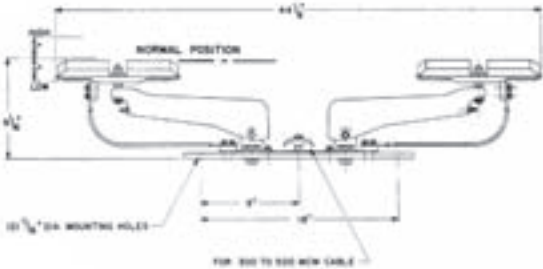

No. 99574

No. 99305

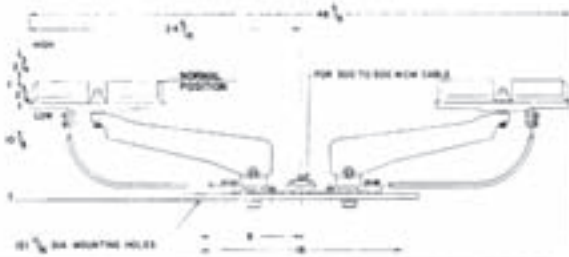

No. 98986

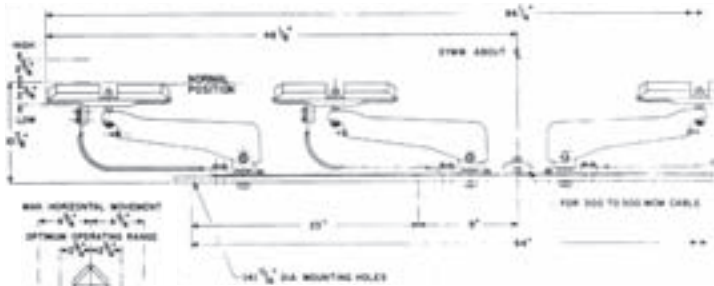

No. 99542











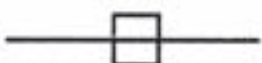

System Layout

The first step in preparing a system layout is to select the proper conductor rating required for the installation. Once the conductor size has been selected, the hanger support-centers for that particular size conductor may be selected from the chart shown with the hanger assembly on Page 3. In order to determine if an expansion joint is required, refer to the fixed expansion joint chart. In the majority of installations none is required. In the event a building expansion joint occurs near mid-point in the system, a floating expansion joint assembly should be considered. Where no expansion joints are required, the system should be anchored approximately in the center. Anchor assemblies are shown on Page 4.

This reduces the effective systems length "L" which is used in the formula to determine the proper conductor amperage rating. Feeders with provision for one to three lugs may be selected from the feeder assemblies. Careful attention must be given to mechanical clearance between components. All splice joints, expansion joints, feeders, and isolation joints must be kept at a minimum of six (6) inches away from the nearest insulated hanger to insure free sliding of the conductor through the hanger.

The following symbols and example layouts are intended for a guide in preparing a layout. However, upon request, TransTech will prepare an application layout to fit your requirements.

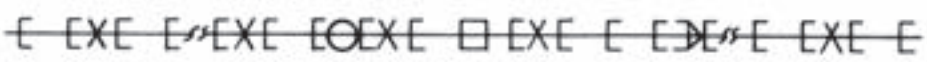
The feeder assembly, if possible, should be located near the center of the system.

Conductor 	Feeder 	Floating Expansion Joint 
Hanger 	Anchor 	
Splice Joint 	Expansion Joint - Fixed 	Isolating Joint 
SYSTEM A — No Expansion Joint — Center Anchored		
SYSTEM B — Fixed Expansion Joint		
SYSTEM C — Floating Expansion Joint		
SYSTEM D — Isolating Joint		

Our prepared application layout drawings will be submitted for each installation.

TECHNICAL DATA

CONDUCTOR SIZE CALCULATION

There are two accepted methods of determining the maximum ampere demand of one or more cranes on a single runway.

Method A

Maximum load equals the sum of all main and auxiliary hoist H.P. plus one-half (1/2) the sum of all bridge motor and trolley H.P.

Method B

Maximum load equals one-half (1/2) the sum of all motor and accessory H.P.

CALCULATION

Load H.P. (Method A or B) x amperes per H.P. (Table A) = maximum ampere demand.

Maximum ampere demand x crane factor (Table C) = adjusted maximum ampere demand.

VOLTAGE DROP CALCULATION

Symbols

VL = Line Voltage at Feeder (Source).

VD = Voltage Drop.

I = Load Amperes.

L = Effective System Length in Feet. Maximum distance from feeder to end of system.

RDC = D. C. Resistance-ohms/1000 feet.

K = Voltage Drop Multiplier (Table B). A factor derived from tests which accounts for variables such as A. C. resistance, inductive reactance, power factor, phase spacing, and conductor shape factors.

Formulas

Direct Current

$$VD = \frac{ILR_{DC}}{500}$$

Alternating Current - Three Phase

(80 percent Power Factor-Flat Spacing)

$$VD = I L K \text{ (Line to Line*)}$$

*For Line to Neutral Voltage Drop divide by 1.73.

Voltage Regulation

$$\% \text{ Regulation} = \frac{VD}{VL-VD} \times 100$$

Example

Length of runway, 400 feet, operating on 440 volts, 3 phase, 60 cycle, phase spacing 6 inches, feeder location-center of runway, one crane on runway. By Method "A," the maximum ampere demand would be calculated as follows:

	ACTUAL H.P.	CALCULATED H.P.
Main Hoist	200	200
Auxiliary Hoist	250	250
Bridge (2 motors at 150 each)	300	150
Trolley	60	<u>30</u>
		Total 280 H.P.

From Table A multiplier is 1.5. 1.5 x 630 H.P. = 945 maximum ampere demand. Based on a 30°C rise over 40°C ambient, you could select the 1200 aluminum V-Bar series for this application.

From Table B, the 1200 Series with a 6 inch phase spacing has a K multiplier of 57.60 x 10⁻⁶ - therefore:

$$VD \text{ (Voltage Drop)} = I \times L \times K$$

$$VD = 945 \times 200 \times (57.60) (10^{-6})$$

$$VD = 10.8 \text{ volts}$$

$$\% \text{ Regulation} = \frac{VD}{VL-VD} \times 100$$

$$\text{Regulation} = \frac{10.8}{440-10.8} \times 100 = 2.5\%$$

TABLE A
Amperes Per Horsepower Conversion

Current	Voltage	Multiplier*
D.C.	115	8
	230	4
	600	1.6
A.C. (3 ϕ)	110	7.0
	220	3.0
	440	1.5
	550	1.2
	2300	0.25
A.C. (2 ϕ)	110	6.0
	220	2.6
	440	1.3
	550	1.1
	2300	0.21

*Average conversion factors calculated from National Electric Code Full Load Current Motor Charts. Motors built for especially low speeds or high torques may require more running current. In which case, name-plate or design current ratings should be used.

TABLE C
CRANE FACTOR (C²)

Current	Multiplier*
1	1
2	0.95
3	0.91
4	0.87
5	0.84

*In the event there are two or more cranes operating on the same load side of the feeder, the multiplying factors shown in Table C would be applied to the maximum ampere demand calculated by Method A or B.

TABLE B

V-Bar Conductor Series	"K"-Voltage Loss Multiplier X 10 ⁻⁶									
	Conductor Phase Spacing — Inches									
	5	5½	6	6½	7	8	9	10	11	12
600	53.5	55.4	57.6	59.5	61.0	63.7	66.1	68.9	71.5	74.0
1200	53.5	55.4	57.6	59.5	61.0	63.7	66.1	68.9	71.5	74.0
2000	-	50.3	51.8	53.6	55.2	58.1	61.0	63.4	65.8	67.7
3000	-	-	-	43.2	45.4	49.6	53.5	56.7	59.3	61.1

Expansion Joint Gap Setting Chart

The gap setting chart is to be used to establish the expansion joint gap setting at the time of installation.

The chart should be used according to the following procedure:

- (a) Determine local ambient temperature range. Example -20 to 100°F
- (b) On A scale, write in the highest expected ambient at point X and decrease in 10 degree increments to the lowest expected ambient.
- (c) Determine the ambient temperature at time of gap setting. From the existing ambient temperature, A' scale, read across to the curve and down to the gap setting. Adjust gap accordingly.

Note: The system should be checked at maximum and minimum temperatures as they first occur. Gap settings will require adjustment if they open greater than maximum at the low ambient, or if they are completely closed at the high ambient.

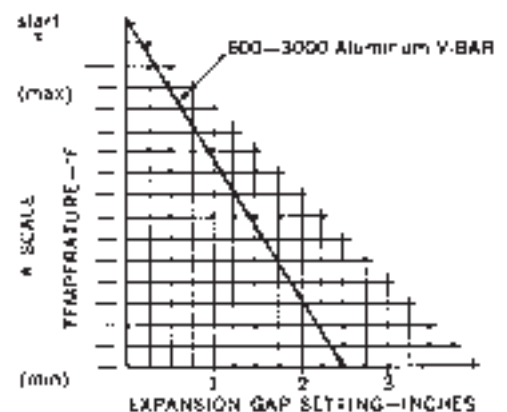

GENERAL SPECIFICATIONS

Conductor-Collector System

The conductor-collector system shall be of the V-Bar Aluminum Series as manufactured by TransTech.

Each system shall consist of necessary conductor sections, hanger supports, insulators, anchor supports, expansion joints, collectors, and/or special components as determined from plans and specifications. The conductor section shall be one-piece aluminum of "V" beam configuration with an inverted V contact surface. The conductor aluminum alloy shall have a minimum conductivity of 56% IACS and a current carrying capacity of (600) (1200) (2000) (3000) amperes based on a 30°C rise over 40°C ambient when operating in still, but unconfined, air. The conductor shall have sufficient thermal capacity to withstand a 300% overload for intermittent duty cycles.

The conductor hangers shall be made from an aluminum casting and shall be nylon coated to provide free conductor movement through the hanger, accommodating expansion or contraction. Splice joints, anchors, feeders, and expansion joints shall be provided as required. These elements shall be manufactured from aluminum extrusions. The design shall be such that only bolting to the conductor is required; no drilling or welding of the rail at erection shall be necessary.

The splice joints, feeders, and expansion joints shall have a current capacity of greater than 100 percent when compared, by the resistance test method (NEMA SGI-5.02), to an equal length of conductor.

The temperature rise of the accessory components shall not exceed the 30°C rise of the conductor with which they are used.

Insulators

The insulators shall be molded from fiber glass reinforced polyester material, as manufactured by TransTech.

The insulator shall have a dew flashover strength when tested per ABA Specification C29.1 of at least four (4) times normal system voltage.

The basic insulator material shall exhibit the following minimum performance levels when tested in accordance with American Society of Testing Materials Specifications. (ASTM).

Property	Minimum	ASTM No.
Dielectric Strength	420VPM	D149
Arc Track Resistance	190 Seconds	D495
Track Resistance Inclined Plane, Min.	Over 1200	D2303
Flammability	Self-Exting.	D635
Heat Distortion Temp. @ 264 psi	595°F	D648
Dissipation Factor, 60HZ	.042	D150
Impact Strength, Ft-Lbs.	4.5	D256
Flexural Strength, psi	18,000	D790

Collectors

The collectors shall have a current carrying capacity of (250) (500) (600) (1200) (1500) (3000) amperes based on a 300°C rise over a 40°C ambient when operated in still, but unconfined air. The collectors shall have sufficient thermal capacity to withstand a 300% overload for intermittent duty cycles. The collectors shall incorporate means of adjusting the contact pressure. The collector shall consist of a high strength aluminum arm which covers the collector spring.

System Features

TransTech's HV-Bar conductor system combines the economy of the lower amp H-Bar systems with the collector tracking and weather protection benefits of the V-Bar system. The HV-Bar conductor is rigid aluminum extruded from 6101-T6 alloy. The HV-Bar system offers simplicity in installation and requires no field welding, drilling or cutting. Assembly is accomplished by means of standard wrenches as hex head bolts are used on all assemblies. Conductors are furnished in factory pre-cut lengths to fit your requirements. Installation and layout drawings showing the location of all components are engineered for your particular requirements and are furnished with each system.

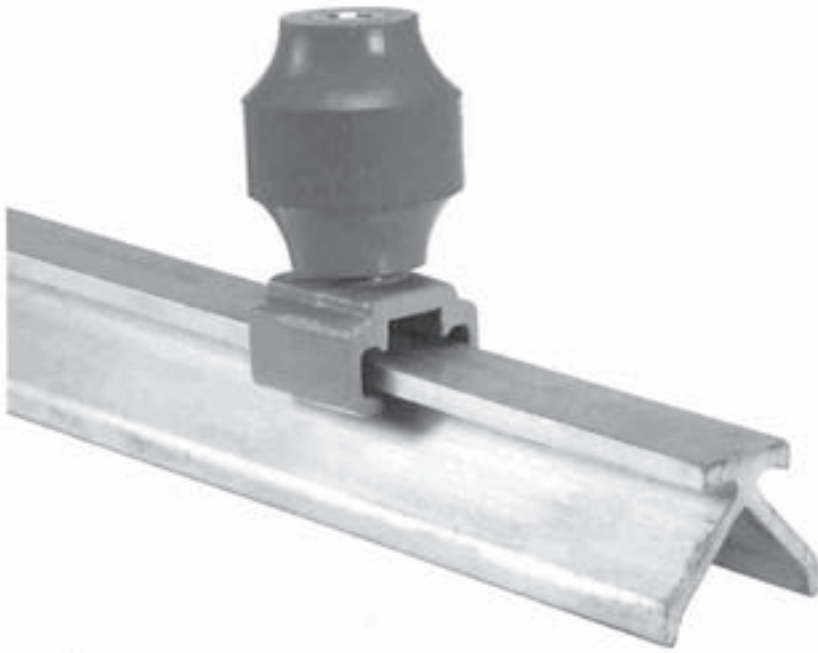

Component	Part Number
Conductor 750 Amps	114546-30
Hanger With 3/8" Bolt	106125
Splice Joint	106130
Anchor	106140
Feeder (1-Lug Provision)	106170
Feeder (2-Lug Provision)	106171
Fixed Expansion Joint	106150
Isolation Joint	106145-02
Insulator 15-51-21	94551-21
Insulator With Petticoat	94571-21
Collector (2) Arm	114563

HV-Bar

Conductor

The HV-Bar conductor is designed for main runway or cross-travel applications. The recommended mounting is in the inverted V position with the collectors in the under-running position. The conductors are normally mounted horizontally with a minimum phase spacing 3 1/2". The conductor is extruded from high conductivity aluminum alloy 6101-T6 and supplied in 30 foot lengths. Shorter lengths can be supplied in one foot increments to match your runway length. The HV-Bar conductor part number is 114546-L where "L" designates the conductor length in feet. Part number 114546-30 is the standard 30 foot long conductor .

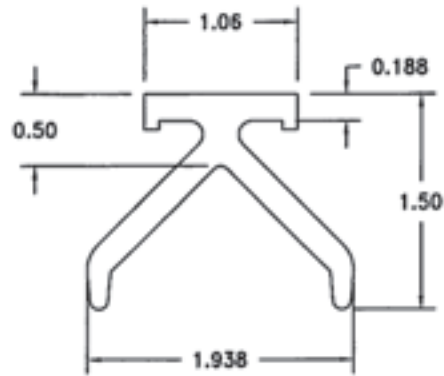

System Amperage Rating	Catalog Number	Area Sq. Inches	Weight Lbs/Ft	D.C. Resistance ohms/ 1000 Ft	A.C. Resistance ohms/ 1000 Ft
750	114546-"L"	0.82	0.96	0.018	0.025

"L" Designates conductor length in feet. Standard length is 30 feet.

Hanger Assembly

The hanger assembly is used with Red-Poly insulators to provide mechanical support and electrical insulation for the conductor system. Hangers are located on five foot spacing. The hanger is made of cast aluminum, nylon coated to assure free sliding through the hanger casting during expansion and contraction of the conductor system. Conductor "lock-up" has been eliminated by the free sliding design, provided components like feeder assemblies and isolation joints are located at least 6" away from adjacent hangers.

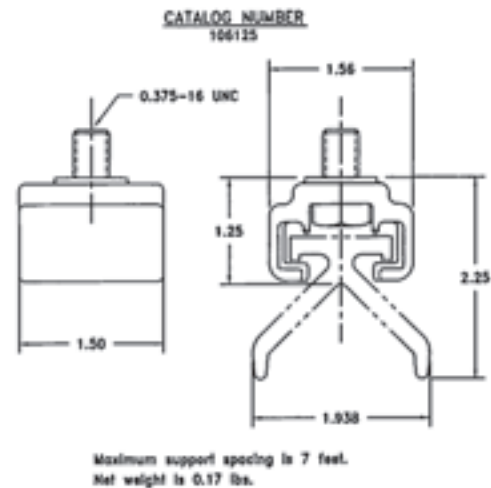

Splice Joint Assembly

The splice joint assembly connects and aligns adjoining conductor sections without drilling or welding. Simplicity of the assembly requires only standard hex wrenches. Bolts secure a spring type, aluminum plate which insures the electrical connection. The aluminum splice joint has an electrical efficiency of greater than 100% when compared by the resistance method to an equal length of conductor. Torque 3/8 - 16 aluminum hex bolts provided with the splice joint assembly to 12 ft-lbs for proper installation.

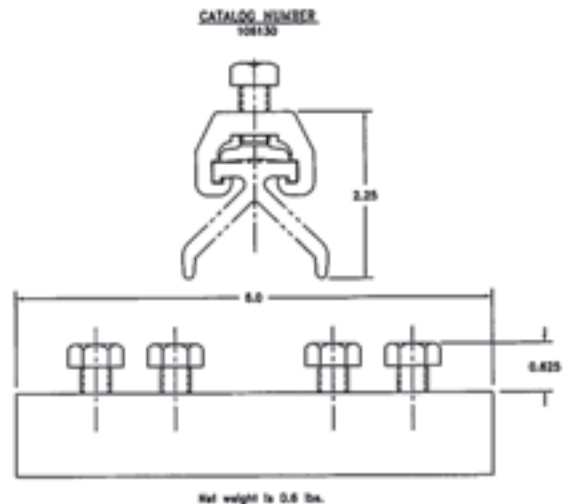

Anchor Assembly

The anchor assembly is used at one location in the conductor system to secure the conductors to a fixed point from which the conductors expand or contract through the hanger castings. The anchor assembly consists of an aluminum extrusion with aluminum hex bolts that securely clamp to the conductor. The anchor assembly replaces a hanger assembly in the system and requires two mounting brackets and two molded insulators.

CATALOG NUMBER
106140

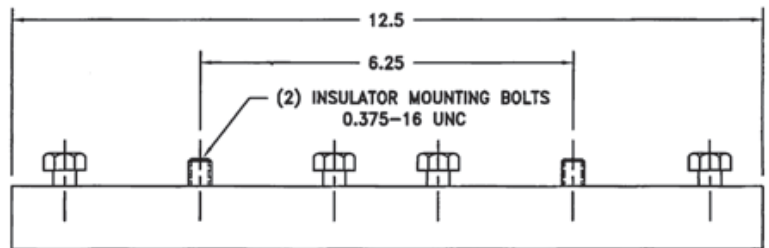

Net weight is 1.2 lbs.

Feeder Assembly

The feeder assembly provides the electrical connection from the power source to the conductor. It may be located at any point on the conductor system. The feeder is normally located at the center of the conductor system. Long systems may require two or more feeders located near the ends of the system to reduce voltage drop. Feeder assemblies must have clearance from adjacent hangers for expansion and contraction of the conductor system. Feeder cables must have enough flex to accommodate conductor movement over the expected operating temperature range. Provisions are made for one or two NEMA standard (1³/₄" terminal lugs per feeder assembly. Terminal lugs are not included with the feeder assembly, but can be provided to match your cable size. Bi-metal plates are provided with each feeder assembly to prevent corrosion between bronze or copper terminal lugs and aluminum extrusions.

CATALOG NUMBER
106170
(1-LUG PROVISION)

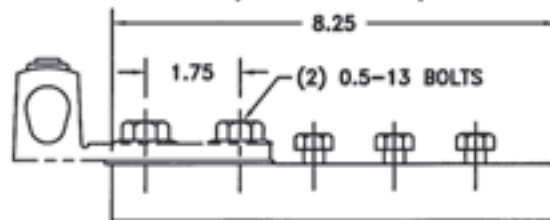

Rating 500 amps at 30 C rise over 40 C ambient
Terminal lug is supplied separate.
Net weight is 0.8 lbs.

CATALOG NUMBER
106171
(2-LUG PROVISION)

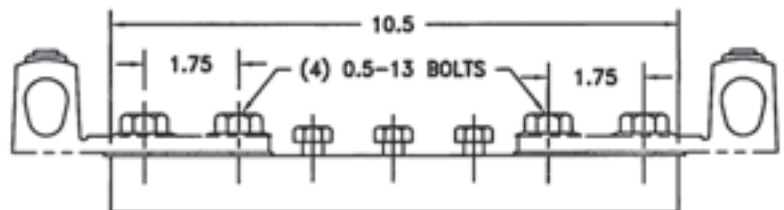

Rating 750 amps at 30 C rise over 40 C ambient
Terminal lugs are supplied separate.
Net weight is 1.3 lbs.

Isolation Joint Assembly

The isolation joint assembly is used to insulate one section of the conductor from an adjacent section without interfering with collector travel. It allows portions of the system to be electrically disconnected while operations continue on the other sections of the conductor system. When more than one crane is operating on the conductor system, the isolation joint is used to create a maintenance area or repair bay. The isolation joint can be inserted at any place in the conductor system. Usually the isolation joints are located 30 feet from each end and replace the last splice assembly on each end of the conductor system. Normally the maintenance area or repair bay is fed electrically through a disconnect switch attached to feeder assemblies on either side of the isolation joint assembly. This arrangement allows for electrical power to be disconnected and “locked out” at a location near the maintenance area or repair bay.

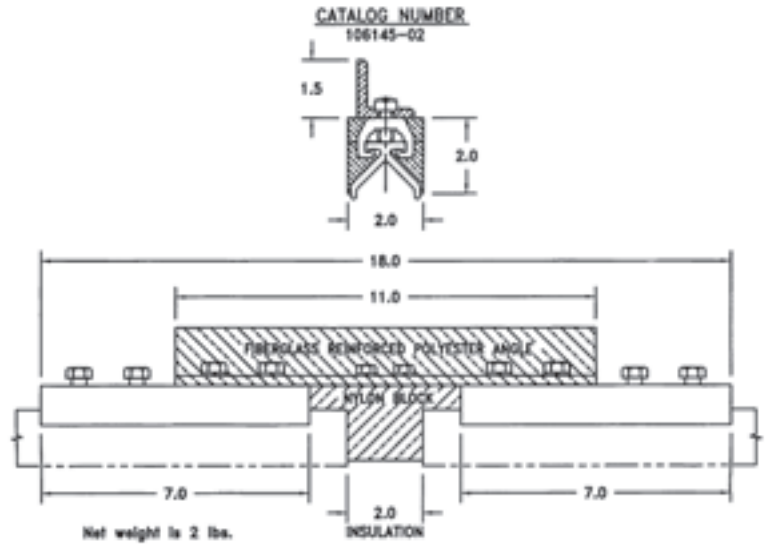

Fixed Expansion Joint Assembly

The expansion joint assembly is necessary on long runways where expansion and contraction of the conductors exceed limits set by TransTech. Normal indoor installations do not require expansion joints if the temperature ranges do not exceed 80 degrees F. Conductor systems longer than 500 feet or systems with extreme temperature variations may require expansion joints.

The conductor gap setting is based on the ambient temperature at the time of installation and the expected temperature variation to which the system will be exposed. At the coolest ambient temperature the gaps must not exceed the maximum expansion gap setting of 1½ inches. At the hottest ambient and operating temperatures the expansion gap should be nearly closed. Electrical continuity during expansion and contraction is maintained through flexible copper shunts. Copper shunts are separated from the aluminum extrusion with bi-metal plates.

Mounting the fixed expansion joint assembly requires two mounting brackets and two molded insulators.

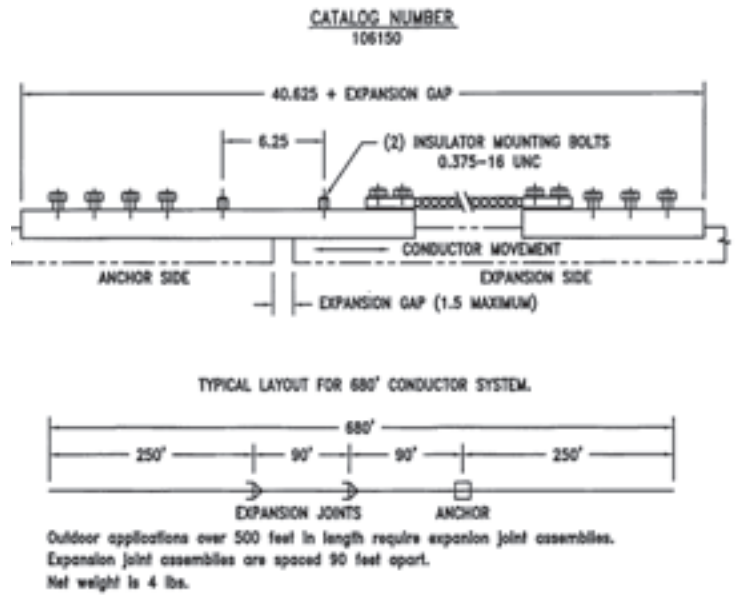

Red-Poly Insulator

The Red-Poly insulators are molded fiberglass reinforced polyester material with superior mechanical strength, excellent electrical characteristics, flame retardant, self extinguishing and track resistant. Red-Poly insulators are manufactured in a variety of styles and heights to match your voltage and application requirements. Red-Poly insulator 15-51-21 is used for most applications.

Mechanical Properties	9455121	9457121
Tensile Strength	3,500 pounds	3,500 pounds
Cantilever Strength	3,000 Inch-pounds	3,000 Inch-pounds
Torsional Strength	600 Inch-pounds	600 Inch-pounds
Weight	0.46 pounds	0.61 pounds
Electrical Properties	9455121	9457121
Dielectric Strength - Dry	38 kV	38 kV
Dew Flashover Strength	15 kV	22 kV
Creep Distance	2.5 Inches	3.6 Inches

CATALOG NUMBER
9455121

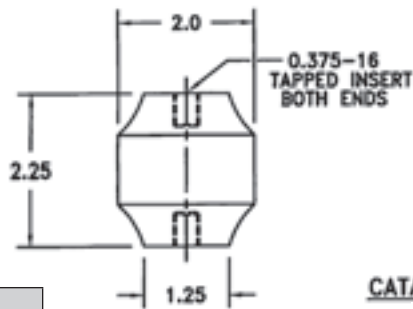

CATALOG NUMBER
9457121

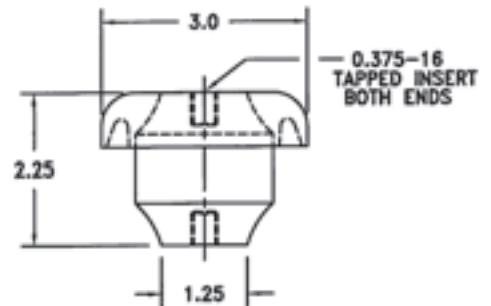

Double Arm Collector HV-Bar

Catalog Number - 114563

Collector Ratings	
Temp. Rise	Current Rating
30° C	400 Amps
40° C	500 Amps

Note:

Collector Horizontal Misalignment is $\pm 2''$

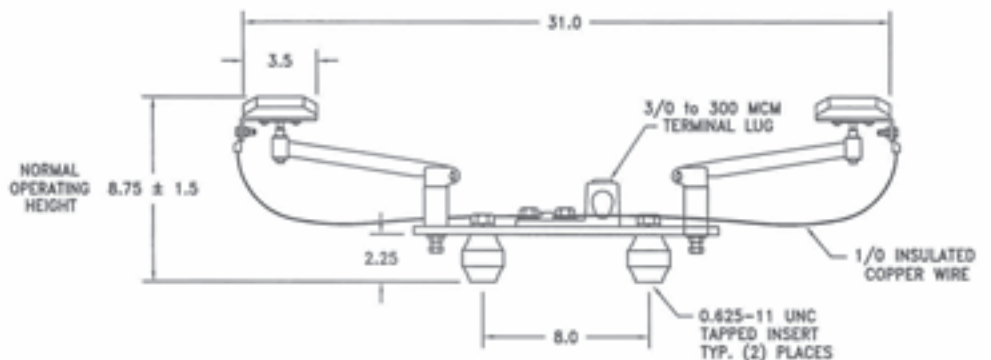

TYPICAL MOUNTING CONFIGURATION

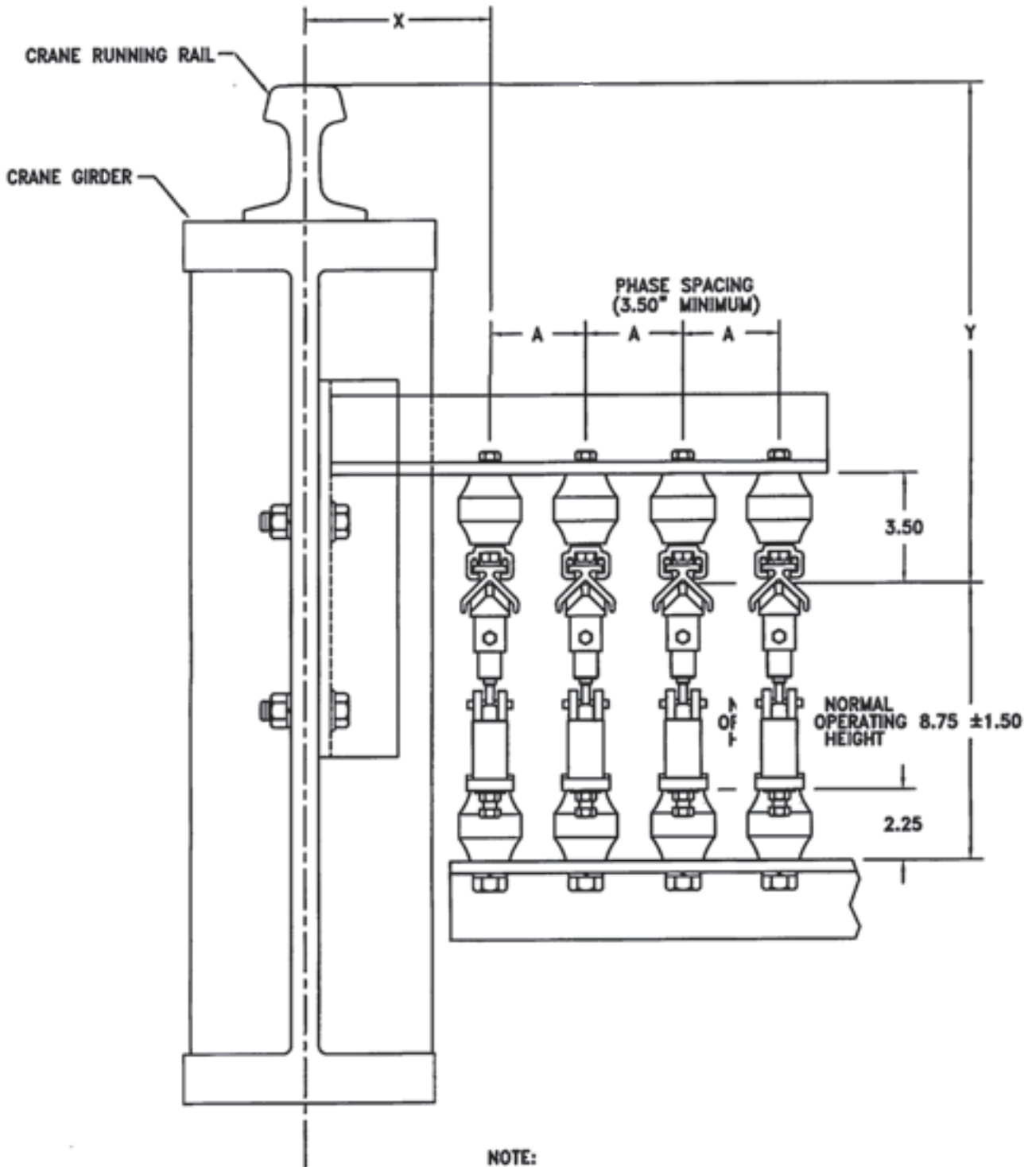

TECHNICAL DATA

MAXIMUM AMPERE DEMAND

Maximum ampere demand equals the sum of all main and auxiliary hoist H.P. plus (1/2) the sum of all bridge and trolley motor H.P.

CALCULATION

Load H.P. x amperes per H.P. (Table A) = maximum ampere demand.

Maximum ampere demand x crane factor (Table C) = adjusted maximum ampere demand.

VOLTAGE DROP CALCULATION

Symbols

ΔV = Line Voltage at Feeder (Source).

V = Voltage Drop.

I = Load Amperes.

L = Effective System Length in Feet. Maximum distance from feeder to end of system.

RDC = D. C. Resistance-ohms/1000 feet.

K = Voltage Drop Multiplier (Table B).

TABLE A		
Current	Voltage	Multiplier
Amperes Per Horsepower Conversion Table	D.C. 230 V	4.0
	D.C. 600 V	1.6
	A.C. 220 V	3.0
	A.C. 440 V	1.5

TABLE B											
HV-Bar	K Values x 10 ⁻⁶										
	Phase Spacing In Inches										
	3 1/2	4	4 1/2	5	5 1/2	6	6 1/2	7	7 1/2	8	9
750A	72	75	78	81	83	85	87	89	91	93	95

Formulas

Direct Current

$$\Delta V = \frac{I \times L \times RDC}{500}$$

Δ .C. 3 phase (80% power factor)

$$\Delta V = I \times L \times K \text{ (Line to Line)}$$

Example

Length of runway, 400 feet, operating on 440 volts, 3 phase, 60 Hz, phase spacing 5 inches, feeder location-center of runway, one crane on runway. Maximum ampere demand would be calculated as follows:

	ACTUAL H.P.	CALCULATED H.P.
Main Hoist	200	200
Auxiliary Hoist	150	150
Bridge	200	100
Trolley	50	<u>25</u>
		Total 475

From Table A multiplier is 1.5. 1.5 x 475 H.P. = 713 ampere

From Table B, the (phase spacing of 5")

$$K = 81 \times 10^{-6}$$

$$\Delta D = 713 \times 200 \times 81 \times 10^{-6}$$

$$\Delta D = 11.55$$

$$\text{Regulation} = \frac{\Delta D}{V - \Delta D} \times 100$$

$$\text{Regulation} = \frac{11.55}{440 - 11.55} \times 100$$

$$\text{Regulation} = 2.7\%$$

TABLE C		
Crane Factor	Cranes Per Runway	Multipling Factor
	1	1
	2	0.95
	3	0.91
	4	0.87

System Features

- 1750, 2500, 4000 and 6000 amp capacities available
- AC or DC voltages up to 4160V based on insulator selection
- 30 foot standard rail lengths. custom lengths available
- Compatible with the corresponding 'H' and 'HC' conductor bar system components
- Suitable for top-running, under-running and side-running installations, with both tracking and non-tracking collectors



<i>HJ Bar Dimensions</i>			
Series	A (in.)	B (in.)	Wt./Ft.
1750	2.50	2.25	7.3
2500	3.25	3.75	9.5
4000	4.00	4.50	12.2
6000	5.00	5.50	16.4

Hybrid Aluminum/Stainless Steel Conductor System

HJ-Bar combines the high conductivity of aluminum with the corrosion resistance and durability of a stainless steel cap into a single conductor bar. Unlike other aluminum/steel designs that use aluminum conductors bolted to standard steel rail to improve electrical performance, HJ-Bar optimizes the aluminum/steel electrical interface through a proprietary manufacturing process that provides continuous contact pressure along the entire length of the rail. This design results in a lightweight, durable and low-maintenance conductor rail. Systems are available with ratings of 1750, 2500, 4000 and 6000 amperes. Larger systems are available upon request.

Features

- Patented manufacturing process ensures low electrical resistance between aluminum and stainless steel components through continuous contact pressure
- Full range of standard components including hangers, anchors, feeders, splice joints, expansion joints, isolation joints and collector assemblies
- Service-proven stainless steel cap design yields high strength without shifting or peeling from the aluminum bar, even under extreme loads
- Hard 3/16" thick stainless steel running surface for extended life under continuous use
- Systems are engineered to customer specifications, including system layout and installation support
- No cleaning or conditioning of the conductor surface required for infrequent use situations

Project Engineering and On-Site Installation Support

TransTech's engineers custom-configure our products and systems to meet each customer's unique application requirements. We provide on-site technical installation support and layout drawings to our customers and their installation teams.

HJ-BAR

STANDARD COMPONENTS — System - Series				
Component	1750 Amps	2500 Amps	4000 Amps	6000 Amps
Conductor Bar	106199	300050	300075	300100
Hanger Assembly	106126	106127	106128	106129
Hanger Assembly (dual insulator)	107826	107827	107828	107829
Splice Joint Assembly (friction)	106132	106134	106136	106137
Splice Joint Assembly (bolt thru)	n/a	300055	300080	300105
Anchor Assembly (friction)	106141	106142	106143	106144
Anchor Assembly (bolt thru)	n/a	300070	300095	300120
Isolating Joint Assembly (friction)	106146	106147	106148	106149
Isolating Joint Assembly (bolt thru)	n/a	300060	300085	300110
Fixed Expansion Joint	106152	106153	106155	106157
Feeder Assembly (friction)	106173	106174	107949	106178
Feeder Assembly (bolt thru)	n/a	300065	300090	300115
Field Drilling Jig	n/a	300051	300076	300101

Conductor

The Aluminum/Stainless Steel HJ-Bar Conductor is designed for main runway or cross travel applications. It may be mounted with the conductor surface in any plane. Under or side running are the most common mounting positions. The "H" configuration was selected for its structural strength allowing maximum hanger spacing, thereby reducing installation costs. The conductor is supplied in maximum 30 foot lengths. Shorter lengths are available (5 foot minimum) in one foot increments to coincide with your runway length requirements.

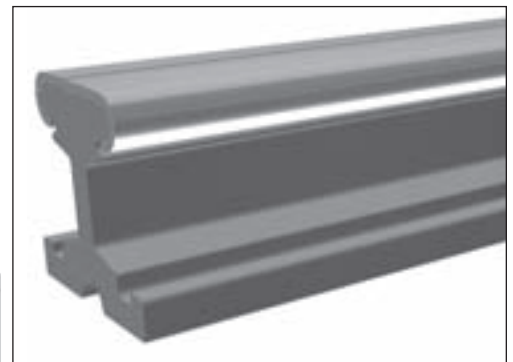
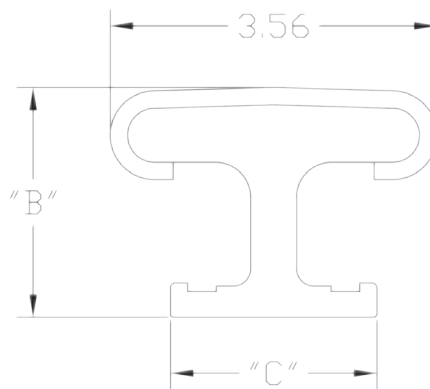

System Ampere Rating	Conductor Cat. No.	A	B	C	Cross Sectional Area		Weight Lbs/Ft.	DC Resistance Ohms/ 1000 ft. at 20°C.	AC Resistance Ohms/ 1000 ft. at 20°C.	Self Geometric Distance d s - Inches	Current Rating Amperes-Continuous 40° C. Ambient
					Sq. Inches	MCM					30° C. Rise
1750	106199	3.56	2.51	2.25	3.3	4250	7.3	0.0045	0.0069	1.357	1750
2500	300050	3.56	3.25	3.75	5.2	6650	9.5	0.0028	0.0051	1.680	2500
4000	300075	3.56	4.00	4.50	7.5	9590	12.2	0.0020	0.0040	2.003	4000
6000	300100	3.56	5.00	5.50	11.1	14120	16.4	0.0013	0.0031	2.411	6000

Hanger Assembly

The hanger assembly is used to support the conductor section with the aid of an insulator. The hanger is made of cast aluminum, nylon coated to assure free sliding during expansion and contraction of the conductor through the hanger. Conductor "lock-up" has been eliminated by this added feature. The hanger, like the conductor, may be mounted in any plane.

Insulator selection depends on the operating voltage of the system and the hanger bolt size.

Dual-Insulator supports also available.

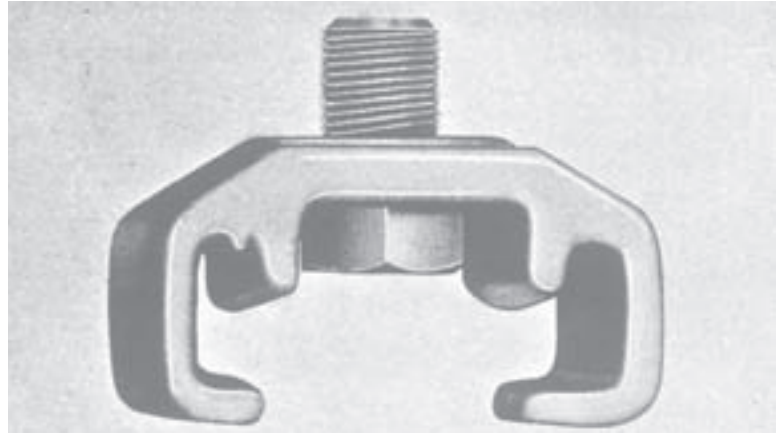
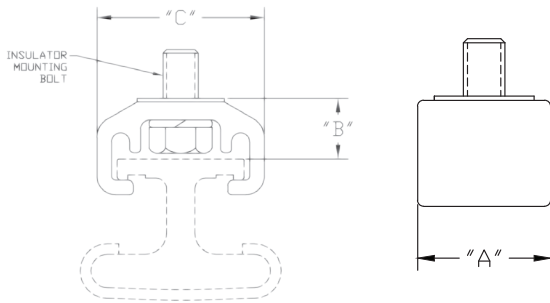

System	Hanger Cat. No.	A	B	C	Insulator Bolt	Maximum Support Centers Feet	Net Weight Lbs.
1750	106126	2	1 ¹ / ₁₆	2 ⁷ / ₈	⁵ / ₈ -11 UNC	12	.31
2500	106127	3	1 ³ / ₈	4 ⁵ / ₈	⁵ / ₈ -11 UNC	14	1.2
4000	106128	3 ¹ / ₂	1 ⁷ / ₈	5 ⁷ / ₈	⁵ / ₈ -11 UNC	16	1.6
6000	Consult TransTech						

Splice Joint Assembly

The splice joint assembly connects and aligns adjoining conductor sections without drilling or welding. Simplicity of the assembly requires only standard hex wrenches. Bolts secure a Belleville-spring-type, aluminum plate which insures the electrical connection.

The aluminum splice joint has an electrical efficiency of greater than 100% when compared by the resistance test method (NEMA SG1-5.02) to an equal length of conductor.

Bolt through splice joints also available.

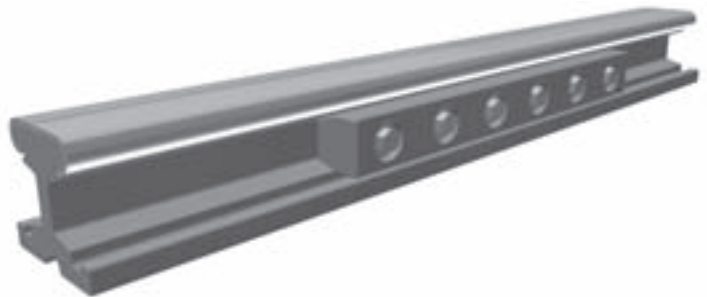
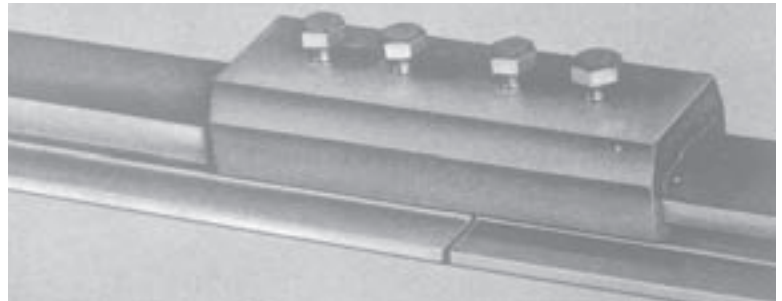
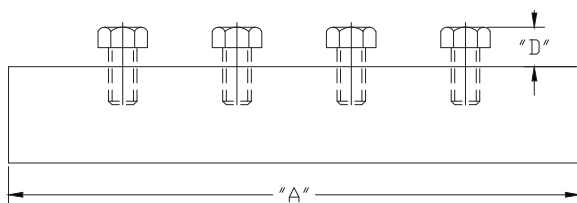
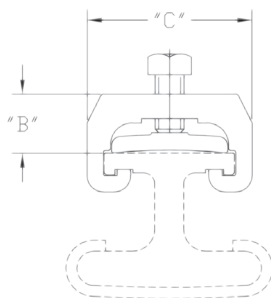

System	Splice Joint Cat. No.	A	B	C	D	Number of Bolts	Rating Amperes 30°C. Over 40°C.	Net Weight Lbs.
1750	106132	10	1 ¹ / ₁₆	2 ⁷ / ₈	⁵ / ₈	4	1750	2.8
2500	300055	Consult TransTech						
4000	300080	Consult TransTech						
6000	300105	Consult TransTech						

Anchor Assembly

Anchor assemblies are employed at one or more points in the system to secure the conductor to a fixed point from which the conductor can expand or contract through the hangers.

The assembly consists of an aluminum extrusion with bolts that securely clamp to the conductor.

An anchor assembly replaces a hanger in the system and requires two mounting insulators.

Insulator selection depends on the operating voltage of the system and the anchor bolt size.

Bolt through anchor assembly also available.

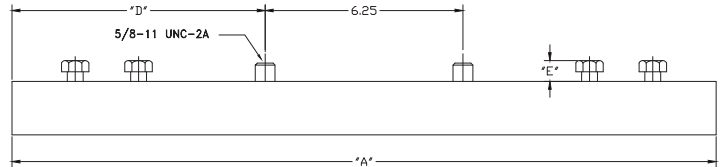
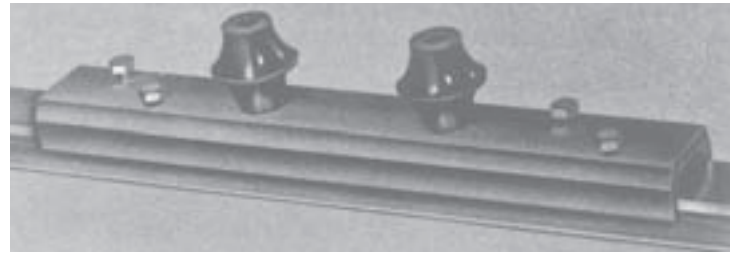
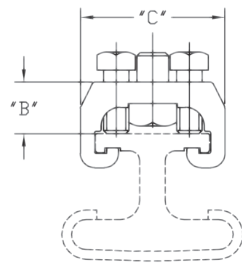

System	Anchor Cat. No.	A	B	C	D	E	Insulator Bolt	Net Weight Lbs.
1750	106141	21	4 ¹ / ₂	2 ⁷ / ₈	7 ³ / ₈	5/ ₈	5/8-11 UNC	5.2
2500	300070	Consult TransTech						
4000	300095	Consult TransTech						
6000	300120	Consult TransTech						

Isolating Joint Assembly

The Isolating Joint Assembly is used to insulate adjacent conductor sections from each other without interfering with collector travel. It allows portions of the system to be electrically disconnected while operations continue on other live sections. At installations where more than one crane will be operated on a single conductor system, the isolating joint is used to create maintenance and repair bays. The isolating joint may be inserted at any point on the system in place of a standard splice joint assembly. When installed, it assures correct alignment between adjacent conductors. There are two methods of feeding the conductor system at isolation joints. (See Diagram).

Each side can be fed individually through adequate safety switches or the isolation joint can be by-passed with the use of feeder assemblies and a suitable disconnect switch.

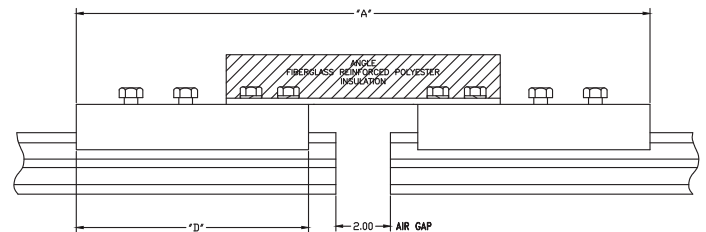
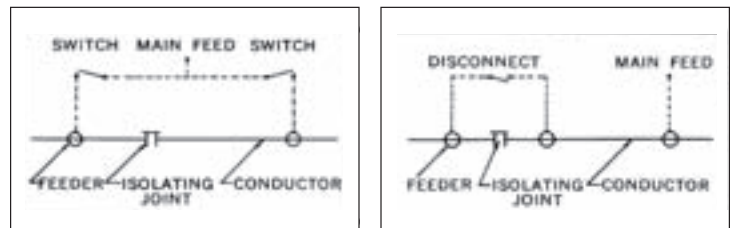
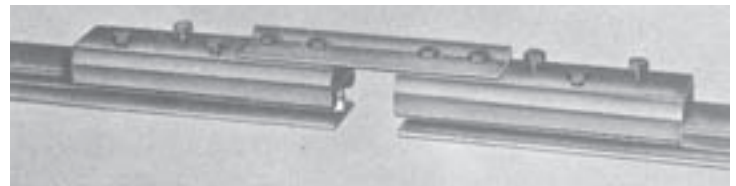

System	Isolating Joint Cat. No.	Type	A	B	C	D	E	Net Weight Lbs.
1750	106146	I	21	1 ¹ / ₁₆	2 ⁷ / ₈	8 ¹ / ₂	2	4.6
2500	300060	Consult TransTech						
4000	300085	Consult TransTech						
6000	300110	Consult TransTech						

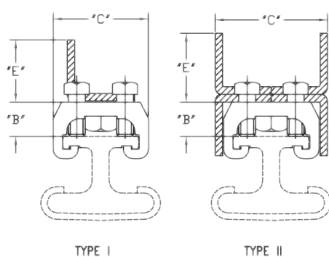

Fixed Expansion Joint

Fixed expansion joints are sometimes necessary to accommodate building or supports structure expansion. Normal indoor installations do not require expansion joints if temperature ranges do not exceed 80°F. Extreme variations in temperature will require expansion joints on longer systems. Electrical continuity is maintained through flexible copper shunts. Shunts are separated from the aluminum by use of bi-metal plates. Conductor gap setting is based on both the ambient temperature at the time of installation and the expected temperature variation to which the system will be exposed. Two insulators are required with each fixed expansion joint.

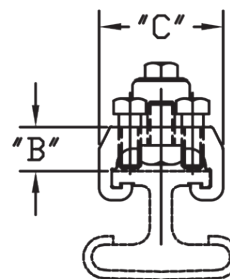
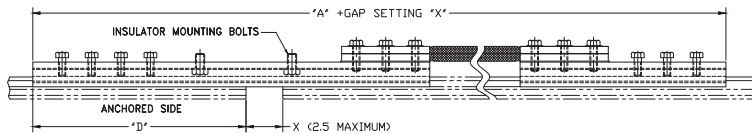
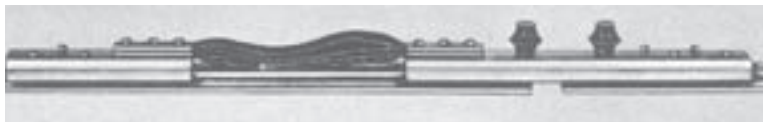

System	Expansion Joint Cat. No	Maximum Expansion (X) inches	A	B	C	D	Insulator Bolt	Rating Amperes 30°C Over 40°C	Recommended Max. System Length				Net Wt Lbs.
									Ft. Center Anchor		Segment Between Expansion Joints		
									Indoor	Outdoor	Indoor	Outdoor	
1750	106152	2 1/2	57	1 1/16	2 7/8	14 1/2	5/8-11 UNC	1750	Not required for normal installation	1500	---	250	19.9
2500	106153	2 1/2	63	1 3/8	4 1/2	18 1/2	5/8-11 UNC	2500		2000	---	400	45.9
4000	106155	2 1/2	66	1 13/16	5 25/32	20	5/8-11 UNC	4000		2500	---	400	55.2
6000	Consult TransTech												

Floating Expansion Joint

Floating Expansion Joints are used only when the gap setting exceeds the fixed expansion joint capability. Electrical continuity is maintained through flexible copper shunts. Shunts are separated from the aluminum by use of bi-metal plates.

Conductor gap setting is based on both the ambient temperature at the time of installation and the expected temperature variation to which the system will be exposed. *NO insulators are required.*

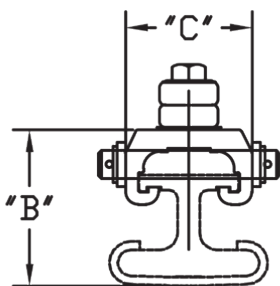
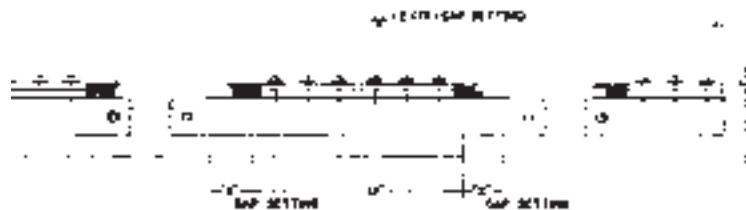

System	Expansion Joint Cat. No	Maximum Expansion (2X) inches	A	B	C	D	Rating Amperes 30°C Over 40°C	Net Wt Lbs.
1750	106165	5	56	3 5/16	3 13/16	1 3/8	1750	37.4
2500	106167	5	56	4 1/8	5 1/2	1 1/8	2500	67.4
4000	106169	5	60	5 13/32	6	1 1/8	4000	80.3
6000	Consult TransTech							

Feeder Assembly

The Feeder Assembly provides the electrical connection from the power source to the conductor system. It may be located at any point within the system.

Long systems should locate the feeder near the center of the system. Feeders should be located no closer than 6 inches from the nearest component. Provisions are made for 1, 2, 3 or 4 feeder lugs. Lugs are *not* furnished with the assembly except by request. Feeders are tapped for standard NEMA type lugs. Bi-metal plates are provided to prevent electrolytic action between aluminum and the bronze or copper lug.

Bolt through feeder assembly also available.

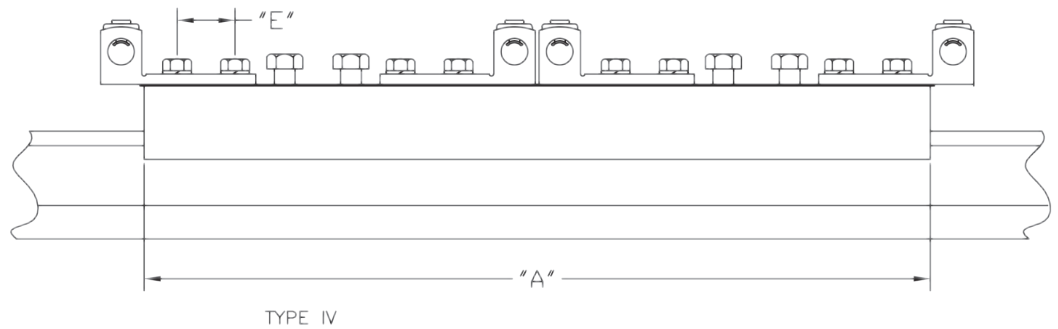
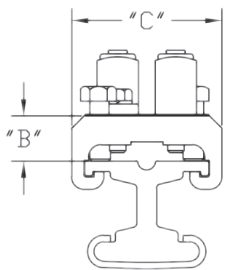
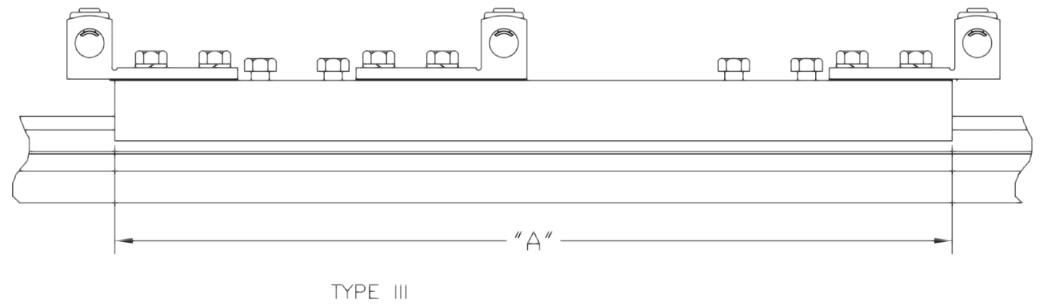
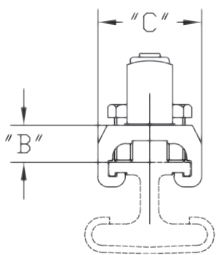
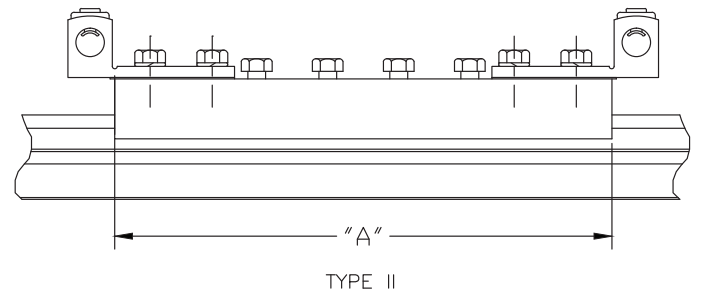
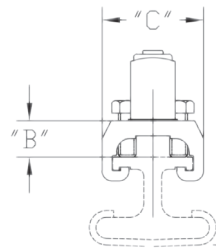
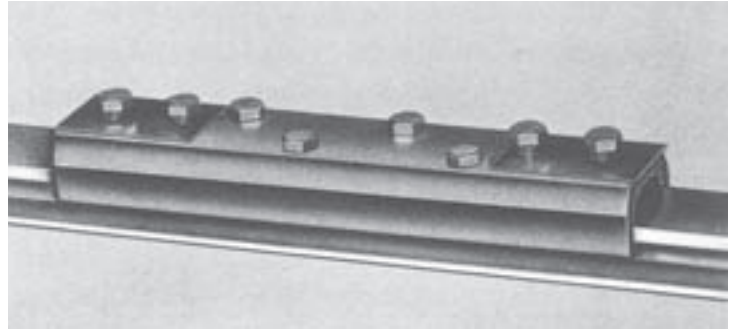

System	Feeder Cat. No	Type	A	B	C	Feeder Lug Provision			Rating Amperes 30°C Over 40°C	Net Wt Lbs.
						Quantity	Bolt Size	Bolt Spacing "E"		
1750	106173	III	23	1 ¹ / ₁₆	2 ⁷ / ₈	3	1/2-13 UNC	1 ³ / ₄	1750	5.7
2500	300065						Consult TransTech			
4000	300090						Consult TransTech			
6000	300115						Consult TransTech			

Collector Assembly

The collector assembly is used to pick up current from the conductor and transmit it to the crane. The contact shoe, which is in contact with the conductor, is made of a metal graphite composition which insures long shoe life without affecting conductor wear. The collector arms are of cast aluminum, and the assembly has provisions for varying the contact shoe pressure by means of an adjustable spring. The arm assembly provides for vertical misalignment while the shoe width accommodates for horizontal misalignment. The entire collector assembly can be mounted in any plane. Under or side running are the most common mounting positions.

Collectors can be provided with one, two, or four arms depending on the current requirements. Two insulators must be used with the one and two arm collector while four are required for the four arm unit. Normally, the same insulator used for the hangers would be employed.

Collector arms, sub-assemblies, contact shoes, and other components are readily available and can be ordered separately, from the entire collector assembly.

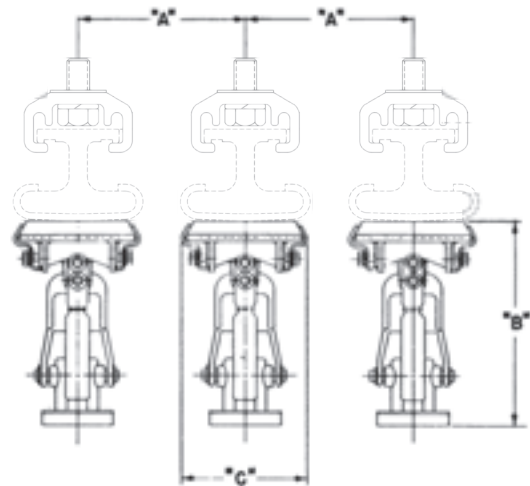
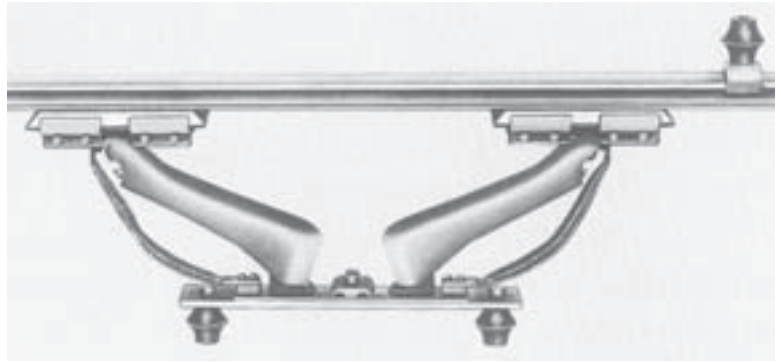

System	Collector Cat. No.	Rating Amperes 30°C Over 40°C	No. of Arms	A Min.	B	C	Net Weight Lbs.
1750	99833	1200	4	6 1/2	8 5/8	5 7/16	116
2500	106394	2000	4	8	10	6 7/16	125
4000	106394	2000	4	8	10	6 7/16	125
6000	106394	2000	4	8	10	6 7/16	125

Current Rating		System Series					
		1750			2500 — 4000 — 6000		
		Single Arm (1)	Double Arm (2)	Four Arm (4)	Single Arm (1)	Double Arm (2)	Four Arm (4)
Catalog Number		99832	99668	99833	106391	106392	106394
Continuous Duty Amperes	30°C	250	600	1200	500	1000	2000
	40°C	350	750	1500	650	1300	2800
	60°C	1000	2200	4400	1200	2400	5000
40°C Ambient	70°C	1200	2500	5000	1500	3000	6000
Intermittent Duty Amperes	1 Min - On	1050	2200	4400	1850	3600	7500
	1 Min - Off						
	5 Min - On	950	2000	4000	1700	3200	7000
40°C Rise Over	5 Min - Off						
	15 Min - On	600	1400	2800	1200	3000	6000
40°C Ambient	15 Min - Off						

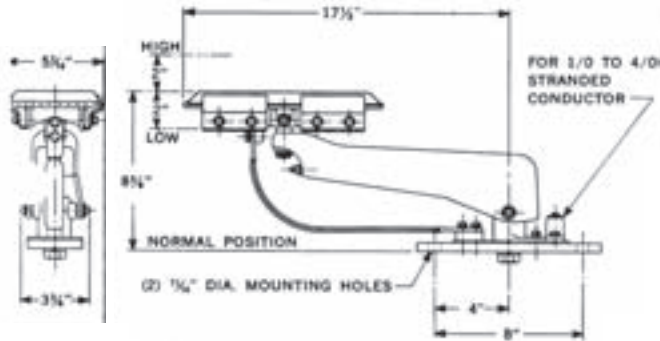

No. 99832

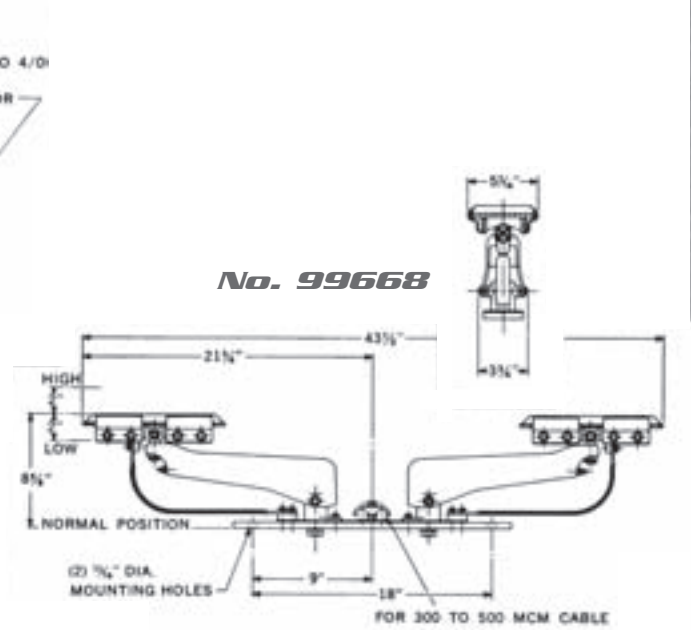

No. 99668

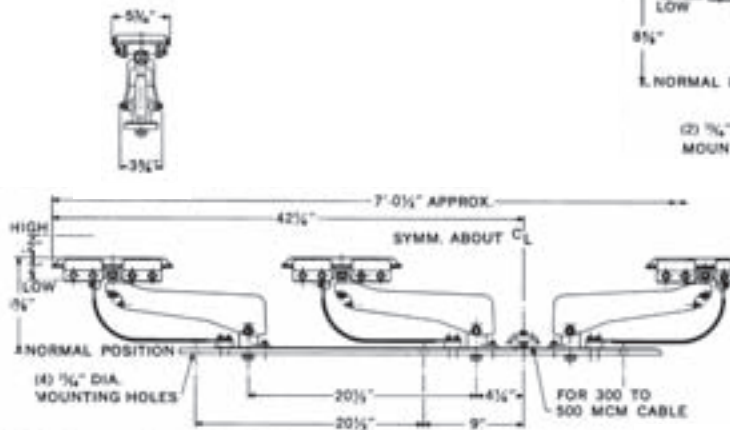

No. 99833

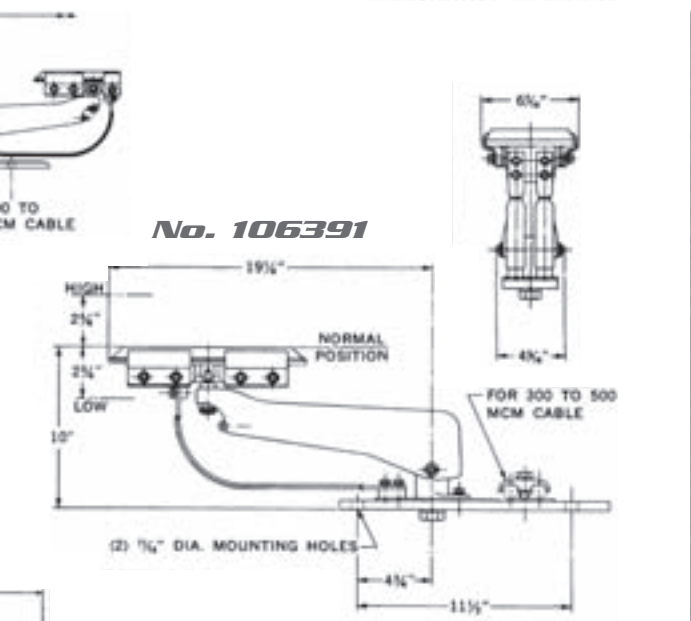

No. 106391

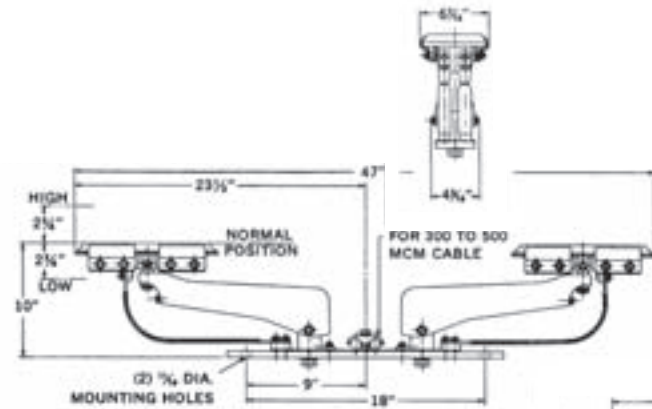

No. 106392

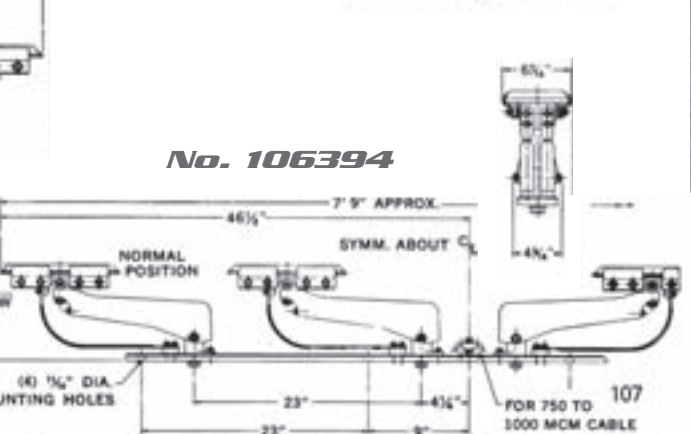

No. 106394











System Layout

The first step in preparing a system layout is to select the proper amperage conductor rating required for the installation. Once the conductor size has been selected the hanger support-centers for that particular size conductor may be selected from the chart shown with the hanger assembly. In order to determine if an expansion joint is required, refer to the fixed expansion joint chart. In the majority of installations none is required. This is due to the advanced design of the nylon coated hanger. In the event a building expansion joint occurs near mid-point in the system, a floating expansion joint assembly should be considered. Where no expansion joints are required the system should be anchored approximately in the center. The feeder assembly, if possible, should be located near

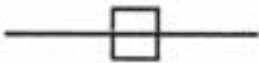
the center of the system. This reduces the effective systems length "L" which is used in the formula to determine the proper conductor amperage rating. Feeders with provisions for one to four lugs may be selected from the feeder assemblies.

Careful attention must be given to mechanical clearances between components. All splice joints, expansion joints feeders, and isolation joints must be kept at a minimum of six (6) inches away from the nearest insulated hanger to insure free sliding of the conductor through the hanger.

The following symbols and example layouts are intended for a guide in preparing a layout. However, upon request Trans Tech will prepare an application layout to fit your requirements.

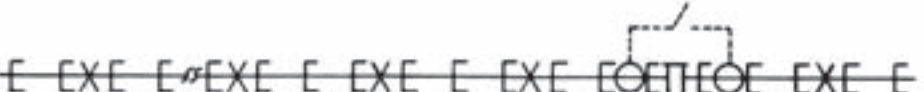
Conductor 	Feeder 	Floating Expansion Joint 
Hanger 	Anchor 	
Conductor 	Conductor 	Conductor 
SYSTEM A — No Expansion Joint — Center Anchored		
SYSTEM B — Floating Expansion Joint		
SYSTEM C — Expansion Joint (Fixed)		
SYSTEM D — Isolating Joint		

TECHNICAL DATA

CONDUCTOR SIZE CALCULATION

There are two accepted methods of determining the maximum ampere demand of one or more cranes on a single runway.

Method A

Maximum load equals the sum of all main and auxiliary hoist H.P. plus one-half (1/2) the sum of all bridge motor and trolley H.P.

Method B

Maximum load equals one-half (1/2) the sum of all motor and accessory H.P.

CALCULATION

Load H.P. (Method A or B) x amperes per H.P. (Table A) = maximum ampere demand.

Maximum ampere demand x crane factor (Table C) = adjusted maximum ampere demand.

VOLTAGE DROP CALCULATION

Symbols

- VL = Line Voltage at Feeder (Source).
- VD = Voltage Drop.
- I = Load Amperes.
- L = Effective System Length in Feet. Maximum distance from feeder to end of system.
- RDC = D. C. Resistance-ohms/1000 feet.
- K = Voltage Drop Multiplier. A factor derived from tests which accounts for variables such as A. C. resistance, inductive reactance, power factor, phase spacing, and conductor shape factors.

Formulas

Direct Current

$$VD = \frac{ILR_{DC}}{500}$$

Alternating Current - Three Phase
(80 percent Power Factor-Flat Spacing)

$$VD=I L K \text{ (Line to Line*)}$$

*For Line to Neutral Voltage Drop divide by 1.73.

Voltage Regulation

$$\% \text{ Regulation} = \frac{VD}{VL-VD} \times 100$$

TABLE A Amperes Per Horsepower Conversion		
Current	Voltage	Multiplier*
D.C.	115	8
	230	4
	600	1.6
A.C. (3 ϕ)	110	7.0
	220	3.0
	440	1.5
	550	1.2
	2300	0.25
A.C. (2 ϕ)	110	6.0
	220	2.6
	440	1.3
	550	1.1
	2300	0.21

*Average conversion factors calculated from National Electric Code Full Load Current Motor Charts. Motors built for especially low speeds or high torques may require more running current. In which case, name-plate or design current ratings should be used.

TABLE C CRANE FACTOR (C²)	
Current	Multiplier*
1	1
2	0.95
3	0.91
4	0.87
5	0.84

*In the event there are two or more cranes operating on the same load side of the feeder, the multiplying factors shown in Table C would be applied to the maximum ampere demand calculated by Method A or B.

Expansion Gap Setting Guide

The following chart is provided as a means of determining the initial expansion gap setting, depending upon application ambient conditions.

The chart should be used according to the following procedure:

- (a) Select system under consideration and respective curve line, indicating maximum gap opening.
- (b) Determine local ambient temperature range: Example -20 to 100°F.
- (c) Starting at point X on A scale, write in the ambient range starting at highest expected ambient and decrease in 10 degree increments to the lowest expected ambient.
- (d) Determine ambient temperature at time of gap setting. From the existing ambient temperature, A scale, read across to the appropriate curve and down to the gap setting. Adjust conductor accordingly.

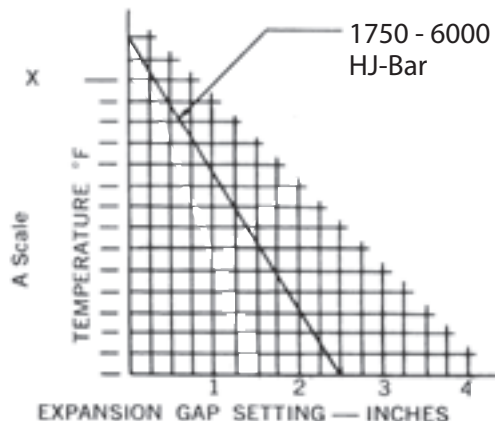

GENERAL SPECIFICATIONS

The conductor-collector system shall be of the HJ-Bar Aluminum/Stainless Steel Series as manufactured by Trans Tech.

Each system shall consist of necessary conductor sections, hanger supports, insulators, anchor supports, expansion joints, collectors, and/or special components as determined from plans and specifications.

The conductor section shall be aluminum/stainless steel of HJ-Bar configuration. The conductor aluminum alloy shall have a minimum conductivity of 56% IACS and a current carrying capacity of (1750) (2500) (4000) (6000) amperes based on a 30°C rise over 40°C ambient when operating in still, but unconfined air. The conductor shall have sufficient thermal capacity to withstand a 300% overload for intermittent duty cycles.

The conductor hangers shall be cast of high strength aluminum alloy. The hanger will be nylon coated to provide free conductor movement through the hanger to accommodate expansion or contraction of the conductor rail. Splice joints, anchors, feeders, and expansion joints shall be provided as required. These elements shall be manufactured from the same aluminum alloy as the conductor rail. The design shall be such that only bolting to the conductor is required; no drilling or welding of the rail at erection shall be necessary.

The splice joints, feeders, and expansion joints shall have an electrical efficiency of greater than 100 percent when compared by the resistance test method (NEMA SG 1-5.02) to an equal length of conductor.

The temperature rise of the accessory components shall not exceed the 30°C rise of the conductor with which it is intended.

Insulators

The insulators shall be of the Red-Poly Type, molded from fiberglass reinforced polyester material, as manufactured by Trans Tech. The insulator shall have a dew flashover strength when tested per ABA Specification C29.1 of at least four (4) times normal system voltage.

The basic insulator material shall exhibit the following minimum performance levels when tested in accordance with American Society of Testing Materials Specifications. (ASTM)

Property	Minimum	ASTM No.
Dielectric Strength	400VPM	D149
Arc Track Resistance	180 Seconds	D495
Flame Retardance	Self-Exting.	D635
Heat Distortion Temp. @ 264 psi	400°F	D648
Dissipation Factor, 60N	.035	D150
Impact Strength, Ft-Lbs.	4	D256
Flexural Strength, psi	16,000	D790

Collectors

The collectors shall have a current carrying capacity of (250) (500) (600) (1000) (1200) (2000) amperes based on a 30°C rise over a 40°C ambient when operated in still, but unconfined air. The collectors shall have sufficient thermal capacity to withstand a 300% overload for intermittent duty cycles. The collectors shall incorporate means of adjusting the contact pressure. The collector shall consist of a high strength aluminum arm which covers the collector spring.

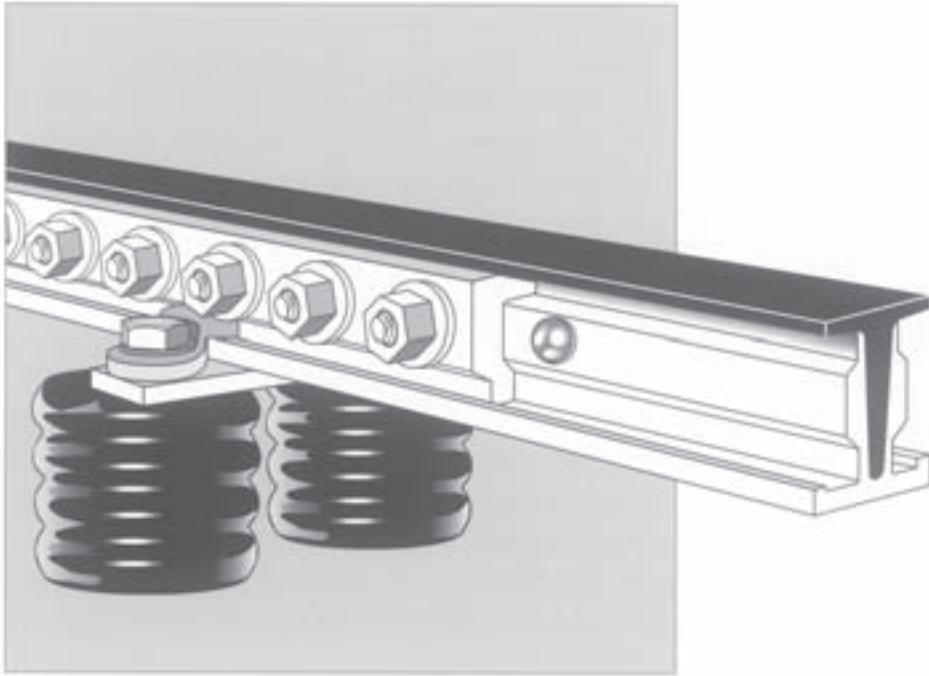

System Features

HC-Bar was developed to provide a constant source of electrical power to movable equipment . . . easily and economically. Designed primarily for use on cranes, HC-Bar can be used for practically all applications — exterior and interior — where a steel contact surface is preferred.

The high carbon steel contact surface is adaptable for use with both gravity or spring-loaded collectors using cast iron contact shoes. The aluminum section of the rail provides the conductivity necessary to carry the system's amperage requirements without the use of booster cables. This HC-Bar System is thus able to provide the advantages of both steel and aluminum in one lightweight unit.

Simplicity of design reduces installation costs. Single or double insulator rail supports and anchors offer the flexibility of choice between single insulator mounting, requiring only one hole in support bracket; or double insulator mounting for the larger series rails. Either type system may be mounted in the overrunning or underrunning position.

Flexibility of insulator heights ranging from $2\frac{5}{8}$ " to $3\frac{1}{2}$ ", permits additions to existing steel rail or other type systems.

The HC-Bar Composite Systems can be used for various AC or DC voltage applications depending on insulator selection.

A variety of metal enclosure designs are available for personnel protection under different mounting conditions. Our sales personnel and engineering staff are available for aiding in the selection of the most economical system for your present and future requirements. (Engineered installation drawings are furnished with each system upon request.)

HC-Bar

Conductor

The HC-Bar conductor is designed for main runway or cross-travel applications. It may be mounted in either the overrunning or underrunning position.

The rail consists of two metals-aluminum and high carbon steel. The design of the aluminum body is such that the steel "T" is pressed into position and held firmly by "Compression Bolts." Before assembly the steel "T" section is thoroughly cleaned and coated with a no-oxide compound, creating a sealed interface between the aluminum and steel. This retards oxidation that normally would occur with untreated metals.

Conductor sections are normally supplied in 30 foot sections — each end drilled for splice plates. Shorter lengths can be furnished upon request or if particular application so demands.

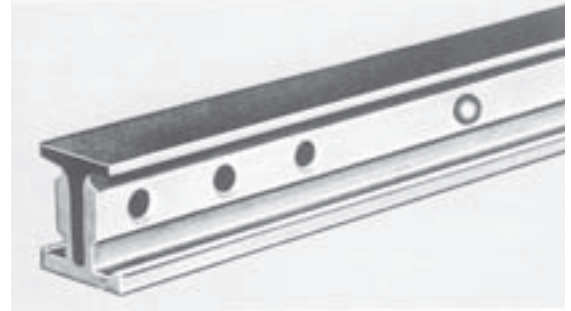
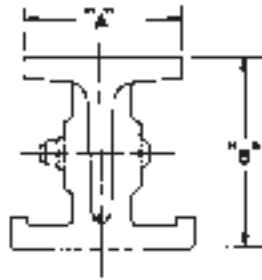

Conductor Rating *	Conductor Cat. No.	D.C. Resistance Ohms/1000 Ft.	A	B	Wt./Ft.
1000	107799	.0105	2	2 ³ / ₈	5.0
1250	107800	.0085	2	2 ³ / ₈	5.4
1500	107801	.0071	2	2 ³ / ₈	5.8
1750	107802	.0060	2	2 ¹ / ₂	6.3
2000	107803	.0046	3	2 ⁷ / ₈	9.5
2500	107804	.0037	3	3 ¹ / ₄	10.4
3000	107805	.0030	4	3 ³ / ₄	14.5
4000	107806	.0024	4	4	15.8
5000	107807	.0019	4	5	22.0

*Rating based on 40°C rise over 40°C ambient.

Hanger Assembly

The hanger assembly is used to support the conductor section either in the underrunning or overrunning position. It is made of cast aluminum, nylon coated to assure free sliding during expansion and contraction of the conductor through the hanger. Conductor "lock-up" has been eliminated by this added feature. This particular assembly requires only one support insulator. Therefore, only one hole is required in the support bracket. It is particularly adaptable for underrunning systems as the hanger and insulator can be slid into position on the conductor and the whole assembly hoisted into position. The hanger can be installed at a splice joint for either underrunning or overrunning operation.

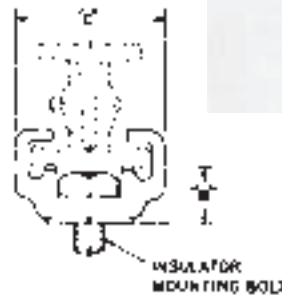
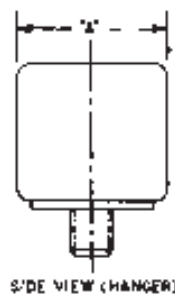

Insulator selection depends on the operating voltage of the system and the hanger bolt size.

Conductor Rating	Hanger Cat. No.	A	B	C	Insulator Bolt	Support Centers (Max.)	Net Weight Lbs.
1000-1750	106126	2	1"	2 ⁷ / ₈	5/8-11 UNC	12'	.31
2000-2500	106127	3	1 ⁵ / ₁₆	4 ⁵ / ₈	5/8-11 UNC	12'	1.2
3000-4000	106128	3 ¹ / ₂	1 ³ / ₄	5 ⁷ / ₈	5/8-11 UNC	12'	3.1
5000	106129	4	1 ¹⁵ / ₁₆	7	3/4-10 UNC	12'	4.2

Dual Insulator Conductor Support

The dual insulator conductor support is designed to provide additional cantilever strength particularly when using the larger series conductors. It can be used in the underrunning or overrunning position. The assembly consists of a steel bar connecting plate with ductile iron rail grips and steel bolts. The bar and grips are nylon coated to assure free sliding of the conductor during expansion and contraction. The rail grip has a radius contact surface to the rail which prevents conductor "lock-up." In addition, it allows the installation of the conductor to be made without removing the bolts from the insulator. The support can be located at a splice joint in either the underrunning or overrunning position.

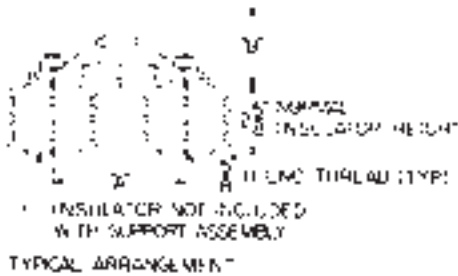
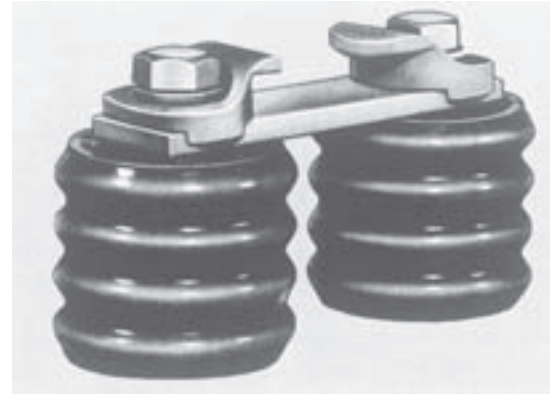

Conductor Rating	Rail Support Cat. No.	A	B	Insulator Bolt	Support Centers (Max.)	Net Weight Lbs.
1000	107826	4 ¹ / ₄	2 ⁵ / ₈	5/8-11 UNC	12'	4.3
1250	107826	4 ¹ / ₄	2 ⁵ / ₈	5/8-11 UNC	12'	4.3
1500	107826	4 ¹ / ₄	2 ⁵ / ₈	5/8-11 UNC	12'	4.3
1750	107826	4 ¹ / ₄	2 ³ / ₄	5/8-11 UNC	12'	4.3
2000	107827	6	3 ³ / ₁₆	5/8-11 UNC	12'	4.9
2500	107827	6	3 ⁹ / ₁₆	5/8-11 UNC	12'	4.9
3000	107828	6 ⁷ / ₈	4 ¹ / ₈	5/8-11 UNC	12'	5.7
4000	107828	6 ⁷ / ₈	4 ³ / ₈	5/8-11 UNC	12'	5.7
5000	107829	8	5 ³ / ₈	5/8-11 UNC	12'	6.0

Splice Joint Assembly

The splice joint assembly connects and aligns adjoining conductor sections without drilling or welding. Simplicity of the assembly requires only standard hex wrenches. Galvanized steel bolts and nuts used in conjunction with Belleville spring-type washers are employed to securely fasten the two aluminum splice plates to the conductor. The aluminum splice joint has an electrical efficiency of greater than 100% when compared by the resistance test method (NEMA SGI 5.02) to an equal length of conductor. The splice joint can be used for either overrunning or underrunning operation.

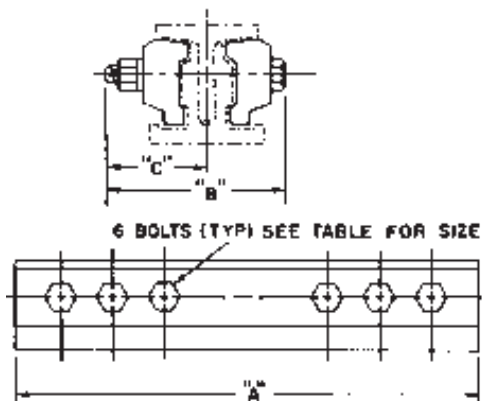
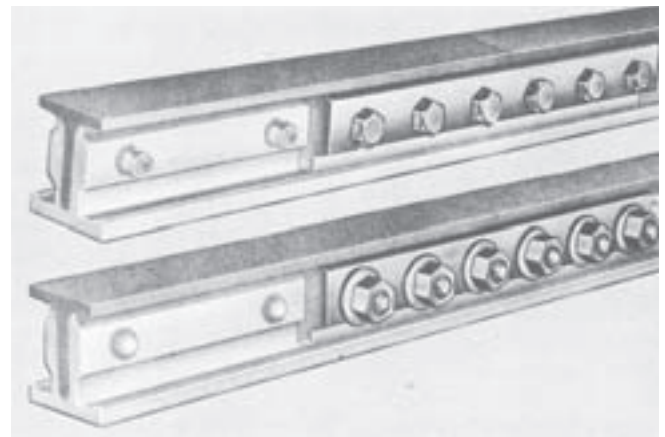

Conductor Rating	Splice Joint Cat. No.	A	B	C	Bolt Size	Net Weight Lbs.
1000	107830	12	3 ¹¹ / ₃₂	2	1/2-13 UNC	2.6
1250	107830	12	3 ¹¹ / ₃₂	1 ⁷ / ₈	1/2-13 UNC	2.6
1500	107831	12	3 ⁵ / ₈	2 ¹ / ₁₆	1/2-13 UNC	4.2
1750	107832	12	3 ⁵ / ₈	2	1/2-13 UNC	4.3
2000	107833	18	4 ¹ / ₁₆	2 ¹ / ₄	1/2-13 UNC	7.0
2500	107834	18	4 ¹ / ₁₆	2 ¹ / ₄	1/2-13 UNC	7.5
3000	107835	18	5 ⁵ / ₁₆	3	1/2-13 UNC	12.2
4000	107836	18	5 ⁵ / ₁₆	3	1/2-13 UNC	11.8
5000	107837	18	5 ¹³ / ₃₂	3	1/2-13 UNC	18.3

Anchor Assembly

Anchor assemblies are used at one or more points in the system to secure the conductor to a fixed point from which it can expand or contract through the hangers. The assembly consists of an aluminum extrusion with bolts that clamp securely to the aluminum section of the rail.

An anchor assembly replaces a hanger in the system and requires two mounting insulators. Insulators are not furnished with the assembly. Insulator height should be the same as used on the hanger assembly.

Insulator selection depends on the operating voltage of the system and the anchor bolt size.

The anchor assembly can be used for either overrunning or underrunning operation.

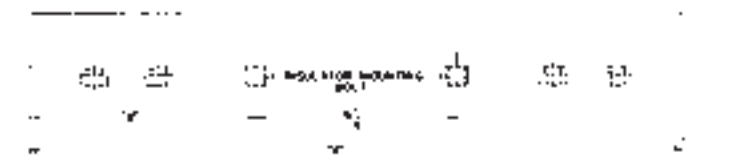
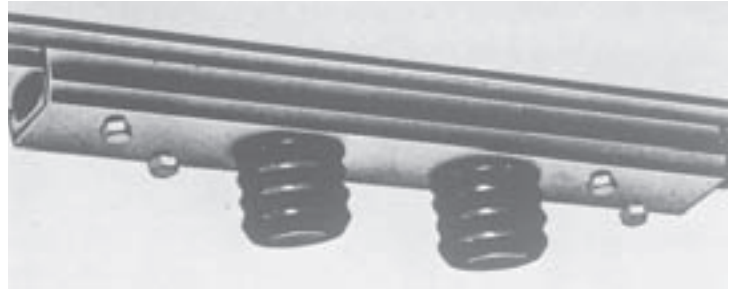

Conductor Rating	Anchor Cat. No.	A	B	C	Insulator Bolt	Net Weight Lbs.
1000-1750	106141	21	7 ³ / ₈	2 ⁷ / ₈	5/8-11 UNC	5.3
2000-2500	106142	25	9 ³ / ₈	4 ¹ / ₂	5/8-11 UNC	15.1
3000-4000	106143	25	9 ³ / ₈	5 ²⁵ / ₃₂	5/8-11 UNC	25.5
5000	106144	29	11 ³ / ₈	6 ²⁹ / ₃₂	5/8-11 UNC	42.0

Dual Insulator Anchor Assembly

The Dual Insulator Anchor Assembly is used with the double insulator rail support shown on page 3.

Anchors are used at one or more points in the system to secure the conductor to a fixed point from which it can expand or contract through the rail supports.

The assembly consists of galvanized steel tie plates, steel angles, and hardware. The anchor replaces a splice joint and hanger and can be installed without field drilling.

In the event an anchor is required in a location other than at a splice joint, a special assembly is available.

Insulators, four required, are not furnished with the assembly.

The anchor assembly can be used for either overrunning or underrunning operation.

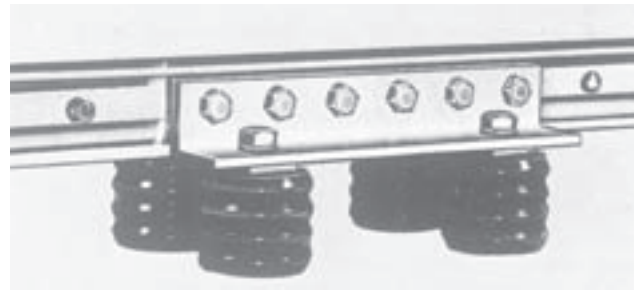

Conductor Rating	Anchor Cat. No.	A	B	C	D	Net Weight Lbs.
1000	107911	4 ¹ / ₄	2 ⁵ / ₈	8	12	9.5
1250	107912	4 ¹ / ₄	2 ⁵ / ₈	8	12	9.5
1500	107913	4 ¹ / ₄	2 ⁵ / ₈	8	12	10.6
1750	107914	4 ¹ / ₄	2 ³ / ₄	8	12	10.7
2000	107915	6	3 ³ / ₁₆	12	18	18.5
2500	107916	6	3 ⁹ / ₁₆	12	18	19.0
3000	107917	6 ⁷ / ₈	4 ¹ / ₈	12	18	24.3
4000	107918	6 ⁷ / ₈	4 ³ / ₈	12	18	24.0
5000	107919	8	5 ³ / ₈	12	18	35.5

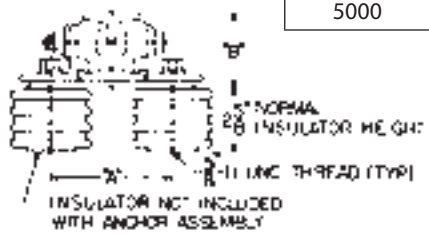

Feeder Assembly

The feeder assembly provides the electrical connection from the power source to the conductor system. It may be located at any point within the system. *NO* field drilling or welding is required. On long systems the feeder should be located near the center of the system which reduces the effective system length, consequently reducing voltage drop.

Feeders should be located no closer than six inches from the nearest component. The assembly consists of an aluminum extrusion with bolts and clamps securely to the aluminum section of the rail. Bi-metal plates are provided to prevent electrolytic action between the aluminum and the bronze, or copper lug.

Provisions are made for 1, 2, 3, or 4 feeder lugs. Lugs are not furnished with the assembly except by request. Feeders are tapped for standard NEMA type lugs.

The assembly can be used for either overrunning or underrunning operation.

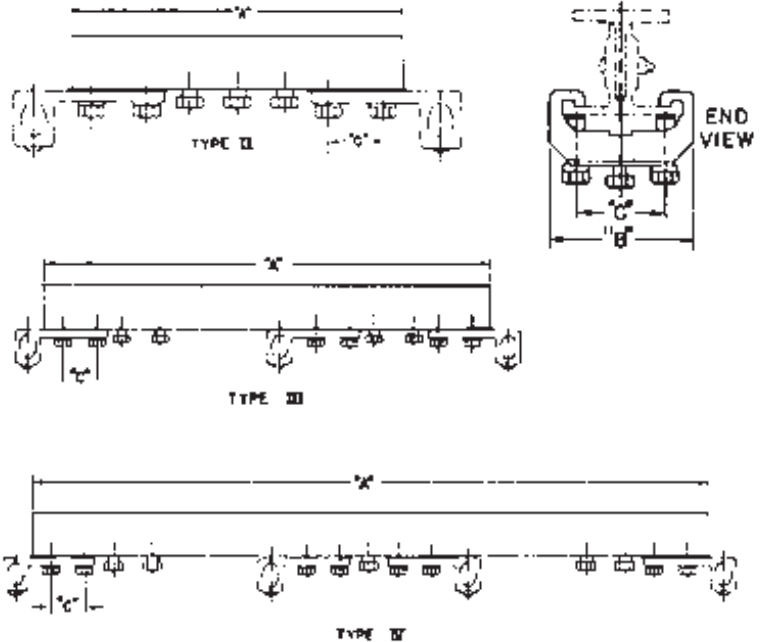
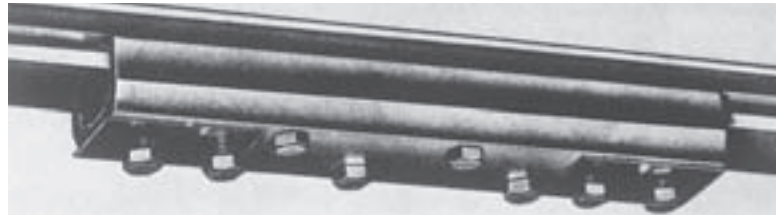

Conductor Rating	Feeder Cat. No	Type	A	B	Feeder Lug Provision			Net Wt Lbs.	
					Qty	Bolt Size	Spacing "C"		
1000-1750	107950	I	8 ¹ / ₄	2 ⁷ / ₈	1	1/2-13 UNC	1 ³ / ₄ "	2.1	
	106172	II	14		2			3.6	
	106173	III	23		3			5.7	
2000-2500	106174	III	23 ³ / ₄	4 ¹ / ₂	3	1/2-13 UNC FOR LUGS HAVING HOLES FOR (2) OR (4) BOLTS		14.9	
	106175	IV	35		4			21.5	
3000-4000	106176	II	18 ¹ / ₂	5 ²⁵ / ₃₂	2			1/2-13 UNC FOR LUGS HAVING HOLES FOR (2) OR (4) BOLTS	20.3
	107948	III	27 ³ / ₄		3				30.1
	107949	IV	39		4				42.1
5000	106177	III	29 ¹ / ₄	6 ²⁹ / ₃₂	3				1/2-13 UNC FOR LUGS HAVING HOLES FOR (2) OR (4) BOLTS
	106178	IV	41		4		59.7		

Fixed Expansion Joint

Fixed expansion joints are sometimes necessary to accommodate building or support structure expansion. Normal indoor installations do not require expansion joints if temperature ranges do not exceed 80°F. Extreme variations in temperature will require expansion joints on longer systems. Electrical continuity is maintained through flexible copper shunts. Shunts are separated from the aluminum by use of bi-metal plates. Conductor gap setting is based on both the ambient temperature at the time of installation and the expected temperature variation to which the system will be exposed. Two insulators are required with each fixed expansion joint. The assembly can be used for either overrunning or under-running operation.

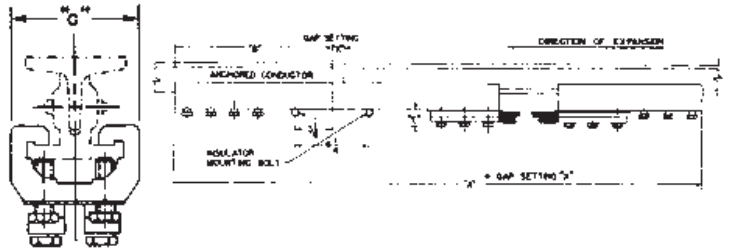

Conductor Rating	Expansion Joint Cat. No	Maximum Expansion (X) inches	A	B	C	Insulator Bolt	Recommended Max. System Length				Net Wt Lbs.
							Ft. Center Anchor		Segment Between Expansion Joints		
							Indoor	Outdoor	Indoor	Outdoor	
1000	106151	2 1/2	57	14 1/2	2 7/8	5/8-11 UNC	NOT REQUIRED FOR NORMAL INSTALLATIONS	500	---	250	18.0
1250	106151	2 1/2	57	14 1/2	2 7/8	5/8-11 UNC		1000	---	250	18.56
1500-1750	106152	2 1/2	57	14 1/2	2 7/8	5/8-11 UNC		1500	---	250	19.96
2000-2500	106153	2 1/2	63	18 1/2	4 1/2	5/8-11 UNC		2000	---	400	45.91
3000	106155-1	2 1/2	63	18 1/2	5 25/32	5/8-11 UNC		2500	---	400	48.71
4000	106155	2 1/2	63	18 1/2	5 25/32	5/8-11 UNC		2500	---	400	49.00
5000	106157	2 1/2	63	18 1/2	6 29/32	3/4-10 UNC		2500	---	400	54.57

Floating Expansion Joint

Floating expansion joints are used only when the gap setting exceeds the fixed expansion joint capability. Electrical continuity is maintained through flexible copper shunts. Shunts are separated from the aluminum by use of bi-metal plates.

Conductor gap setting is based on both the ambient temperature at the time of installation and the expected temperature variation to which the system will be exposed. No insulators are required. The assembly can be used for either over-running or under-running operation.

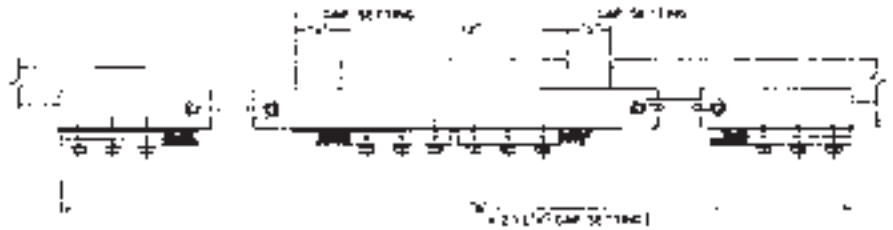

Conductor Rating	Expansion Joint Cat. No	Maximum Expansion (2X) inches	A	B	Net Wt Lbs.
1000	107860	5	56	3 ¹³ / ₁₆	37.0
1250	107860-1	5	56	3 ¹³ / ₁₆	37.4
1500	107861	5	56	3 ¹³ / ₁₆	40.6
1750	107862	5	56	3 ¹³ / ₁₆	41.1
2000	107863	5	56	5 ¹ / ₂	71.2
2500	107864	5	56	5 ¹ / ₂	73.1
3000	107865	5	56	6 ³ / ₄	101.5
4000	107866	5	56	6 ³ / ₄	102.8
5000	107867	5	56	7 ⁷ / ₈	130.3

Isolating Joint Assembly

The Isolating Joint Assembly is used to insulate adjacent conductor sections from each other without interfering with collector travel. It allows portions of the system to be electrically disconnected while operations continue on other live sections. At installations where more than one crane will be operated on a single conductor system, the isolating joint is used to create maintenance and repair bays. The isolating joint may be inserted at any point on the system in place of a standard splice joint assembly. When installed, it assures correct alignment between adjacent conductors. There are two methods of feeding the conductor system at isolation joints. (See Diagram).

Each side can be fed individually through adequate safety switches or the isolation joint can be by-passed with the use of feeder assemblies and a suitable disconnect switch.

System	Isolating Joint Cat. No.	Type	A	B	C	D	Net Weight Lbs.
1000-1750	106146	I	21	8 ¹ / ₂	2 ⁷ / ₈	2	4.7
2000-2500	106147	II	25	10 ¹ / ₂	5	2 ¹ / ₄	14.5
3000-4000	106148	II	29	12 ¹ / ₂	6 ³ / ₈	2 ¹ / ₄	28.8
5000	106149	II	30	13	8	2 ¹ / ₄	40.5

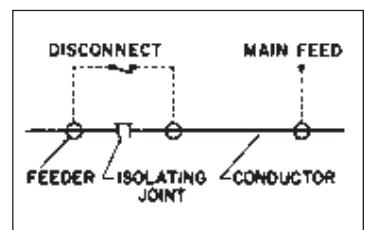
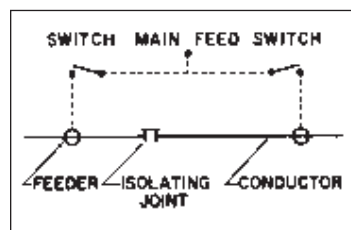
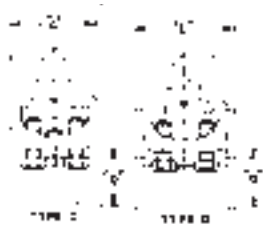

Collectors

Features

Collectors consist of an assembly of a vertical mounting frame plus a spring loaded arm supporting the contact member. Adjustable spring assures proper contact with the conductor and may be varied to meet the particular working conditions.

Types LMI, LM Pony and LM Standard are assembled at TransTech for either overrunning or underrunning service.

The mounting frame is provided with a corrugated surface around an elongated slot interlocking with a corrugated washer for vertical adjustment.

Feeder connections are made to a bronze solderless connector on the mounting frame. Flexible copper cable connects the terminal lug and the contact member, thus bridging and bonding the hinged portion.

Replaceable contact member on all styles are reversible, thereby providing increased life. These contact members have a swiveling action to allow for any slight misalignment in the conductor.

LMI Pony Size Collectors						
LMI Collector	Extension B	Contact Member	Range*		Net Wt. Each—Lbs.	Catalog Number
			Up	Down		
Overrunning	7 ³ / ₈ "	88810	1 ⁵ / ₈ "	1 ⁵ / ₈ "	16	95659
Underrunning	7 ³ / ₈ "	88810	1 ⁵ / ₈ "	1 ⁵ / ₈ "	16	95659

*Range measurements apply to the vertical range with the collector in a horizontal position and measured from the point at the center of the member.
**When ordering, specify by catalog number.

LM Pony Size Collectors						
LM Pony	Extension B	Contact Member	Range*		Net Wt. Each—Lbs.	Catalog Number
			Up	Down		
Underrunning	4 ¹⁵ / ₁₆ "	45650	5/ ₈ "	1"	12	98637
Overrunning	4 ¹⁵ / ₁₆ "	45650	1"	5/ ₈ "	12	76512
Underrunning	7 ³ / ₈ "	45650	1"	1 ⁵ / ₈ "	13	98634
Overrunning	7 ³ / ₈ "	45650	1 ⁵ / ₈ "	1"	13	76514

LM Standard Size Collectors						
LM Standard	Extension B	Contact Member	Range*		Net Wt. Each—Lbs.	Catalog Number
			Up	Down		
Underrunning	9 ⁵ / ₁₆ "	45715	1"	1 ¹ / ₄ "	67	45712
Overrunning	9 ⁵ / ₁₆ "	45715	1 ¹ / ₄ "	1"	67	76507
Underrunning	10 ¹³ / ₁₆ "	45715	1 ¹ / ₄ "	1 ³ / ₈ "	69	45713
Overrunning	10 ¹³ / ₁₆ "	45715	1 ³ / ₈ "	1 ¹ / ₄ "	69	76508
Underrunning	12 ⁵ / ₁₆ "	45715	1 ¹ / ₂ "	1 ³ / ₄ "	71	45714
Overrunning	12 ⁵ / ₁₆ "	45715	1 ³ / ₄ "	1 ¹ / ₂ "	71	76509
Underrunning	15 ¹ / ₁₆ "	45715	1 ⁷ / ₈ "	2 ¹ / ₂ "	75	48474
Overrunning	15 ¹ / ₁₆ "	45715	2 ¹ / ₈ "	2 ¹ / ₈ "	75	76510

*Range measurements apply to the vertical range with the collector in a horizontal position and measured from a point at the center of the member.

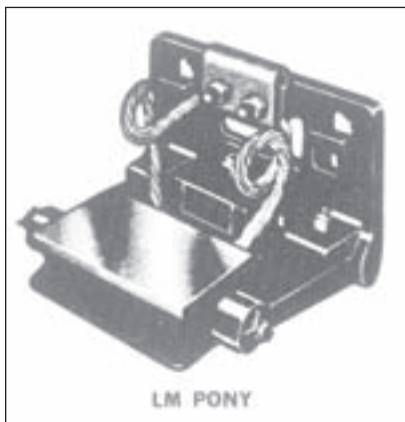
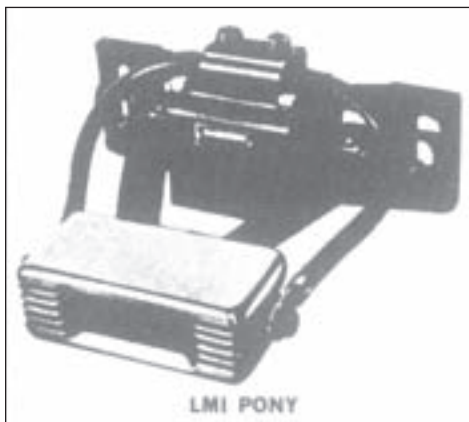

Collectors

LM Standard Size
(Underrunning and Overrunning)

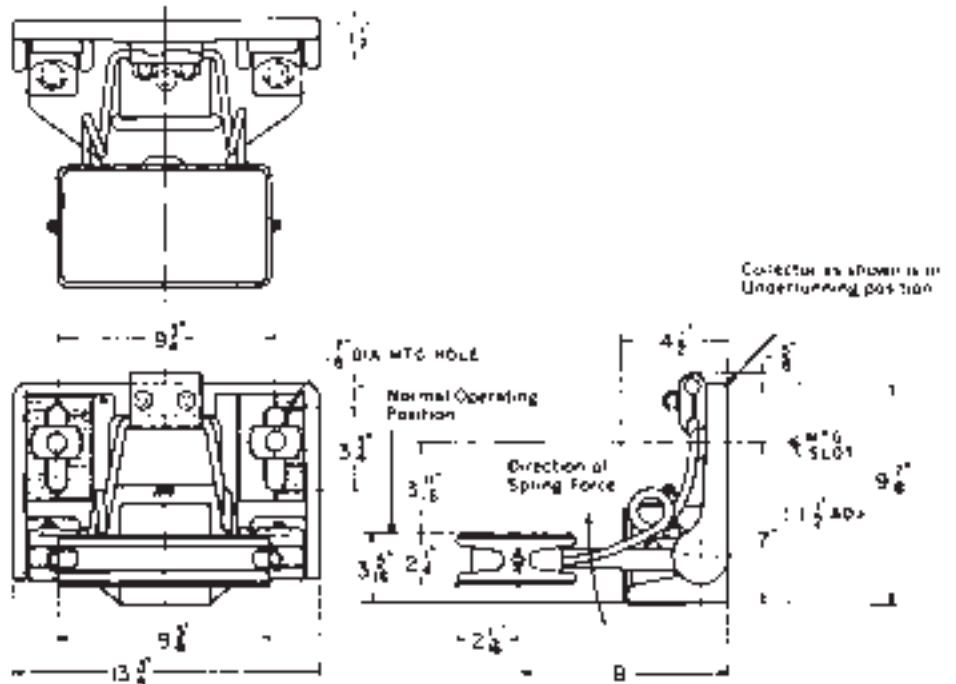

Comparison Chart			
	LMI Pony Series	LM Pony Series	LM Standard Series
Approx. Current Capacity(Amperes) Continuous Load Intermittent Load	250 500	250 500	550 1000
Contact Member	Contact Surface 2 3/4" x 5 9/16" Cast Iron. Copper Coated. Reversible.	Contact Surface 2 1/2" x 4 1/2" Cast Iron. Reversible.	Contact Surface 5" x 9" Cast Iron. Reversible.
Bronze Cable Terminals	Adjustable for wire diameters .414" to .528"	Adjustable for wire diameters .414" to .528"	Adjustable for wire diameters .536" to .772"
Service	Under or Overrunning	Under or Overrunning	Under or Overrunning
Height of Mounting Back	3 1/16"	5"	9 7/8"
Vertical Adjustment of Corrugated Mounting Washer	1 1/4"	1 1/4"	3"
Mounting Bolt Diam. (Not Included with Collectors)	5/8"	5/8"	5/8"
(Mounting Bolt Length Depends on Mounting conditions.) thickness of back and corrugated washer	15/16"	15/16"	15/16"

TECHNICAL DATA

CONDUCTOR SIZE CALCULATION

There are two accepted methods of determining the maximum ampere demand of one or more cranes on a single runway.

Method A

Maximum load equals the sum of all main and auxiliary hoist H.P. plus one-half (1/2) the sum of all bridge motor and trolley H.P.

Method B

Maximum load equals one-half (1/2) the sum of all motor and accessory H.P.

CALCULATION

Load H.P. (Method A or B) x amperes per H.P. (Table A) = maximum ampere demand.

Maximum ampere demand x crane factor (Table C) = adjusted maximum ampere demand.

VOLTAGE DROP CALCULATION

Symbols

VL = Line Voltage at Feeder (Source).

VD = Voltage Drop.

I = Load Amperes.

L = Effective System Length in Feet. Maximum distance from feeder to end of system.

RDC = D. C. Resistance-ohms/1000 feet.

K = Voltage Drop Multiplier (Table B). A factor derived from tests which accounts for variables such as A. C. resistance, inductive reactance, power factor, phase spacing, and conductor shape factors.

Formulas

Direct Current

$$VD = \frac{ILR_{DC}}{500}$$

Alternating Current - Three Phase

(80 percent Power Factor-Flat Spacing)

$$VD = I L K \text{ (Line to Line*)}$$

*For Line to Neutral Voltage Drop divide by 1.73.

Voltage Regulation

$$\% \text{ Regulation} = \frac{VD}{VL - VD} \times 100$$

Example

Length of runway, 400 feet, operating on 440 volts, 3 phase, 60 cycle, phase spacing 5 inches, feeder location-center of runway, one crane on runway. By Method "A," the maximum ampere demand would be calculated as follows:

	ACTUAL H.P.	CALCULATED H.P.
Main Hoist	200	200
Auxiliary Hoist	250	250
Bridge (2 motors at 150 each)	300	150
Trolley	60	<u>30</u>
		Total 630 H.P.

From Table A multiplier is 1.5. 1.5 x 630 H.P. = 945 maximum ampere demand. Based on a 30°C rise over 40°C ambient, you would select the 1000 series for this application.

From Table B, the 1000 Series with a 9 inch phase spacing has a "K" multiplier of 96 x 10⁻⁶ - therefore:

$$VD \text{ (Voltage Drop)} = I \times L \times K$$

$$VD = 945 \times 200 \times (96) (10^{-6})$$

$$VD = 18.13 \text{ volts}$$

$$\% \text{ Regulation} = \frac{VD}{VL - VD} \times 100$$

$$\text{Regulation} = \frac{18.13}{440 - 18.13} \times 100 = 4.3\%$$

TABLE A
Amperes Per Horsepower Conversion

Current	Voltage	Multiplier*
D.C.	115	8
	230	4
	600	1.6
A.C. (3 ϕ)	110	7.0
	220	3.0
	440	1.5
	550	1.2
	2300	0.25
A.C. (2 ϕ)	110	6.0
	220	2.6
	440	1.3
	550	1.1
	2300	0.21

*Average conversion factors calculated from National Electric Code Full Load Current Motor Charts. Motors built for especially low speeds or high torques may require more running current. In which case, name-plate or design current ratings should be used.

TABLE C
CRANE FACTOR (C²)

Current	Multiplier*
1	1
2	0.95
3	0.91
4	0.87
5	0.84

*In the event there are two or more cranes operating on the same load side of the feeder, the multiplying factors shown in Table C would be applied to the maximum ampere demand calculated by Method A or B.

TABLE B

Conductor Rating	"K"-Voltage Loss Multiplier X 10 ⁻⁶						
	Conductor Phase Spacing — Inches						
	6	9	12	14	16	18	20
1000	84.7	96.0	103.7	107.8	110.9	111.8	112.8
1250	75.6	87.5	94.4	98.5	101.0	103.2	104.8
1500	71.8	80.7	88.3	92.4	95.4	97.8	100.4
1750	67.1	77.1	84.2	87.7	90	93	94.8
2000	59.5	71.9	80.1	83.7	86.7	88.5	89.8
2500		65.4	72.5	76.2	78.7	80.7	82.5
3000		61.1	69.5	74.0	77.4	80.2	82.3
4000		53.6	61.9	66.5	70.2	73.1	75.5
5000		49.6	58.1	62.4	66.6	69.1	71.8

Expansion Gap Setting Guide

The following chart is provided as a means of determining the initial expansion gap setting, depending upon application ambient conditions.

The chart should be used according to the following procedure:

- (a) Determine local ambient temperature rang: Example -20 to 100°F.
- (b) Starting at point X on A scale, write in the ambient range starting at highest expected ambient and decrease in 10 degree increments to the lowest expected ambient.
- (c) Determine ambient temperature at time of gap setting. From the existing ambient temperature, A scale, read across to the appropriate curve and down to the gap setting. Adjust conductor accordingly.

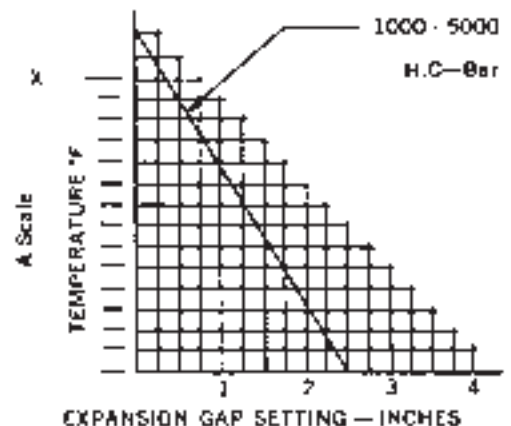

System Layout











The first step in preparing a system layout is to select the proper conductor rating required for the installation. Once the conductor size has been selected, the hanger support-centers for that particular size conductor may be selected from the chart shown with the hanger assembly on Page 2. In order to determine if an expansion joint is required, refer to the fixed expansion joint chart. In the majority of installations none is required. In the event a building expansion joint occurs near mid-point in the system, a floating expansion joint assembly should be considered. Where no expansion joints are required the system should be anchored approximately in the center. Anchor assemblies are shown on Page 4.

The feeder assembly, if possible, should be located near the center of the system.

This reduces the effective systems length "L" which is used in the formula to determine the proper conductor amperage rating. Feeders with provision for one to three lugs may be selected from the feeder assemblies.

Careful attention must be given to mechanical clearance between components. All splice joints, expansion joints, feeders, and isolation joints must be kept at a minimum of six (6) inches away from the nearest insulated hanger to insure free sliding of the conductor through the hanger

The following symbols and example layouts are intended for a guide in preparing a layout. However, upon request, TransTech will prepare an application layout to fit your requirements.

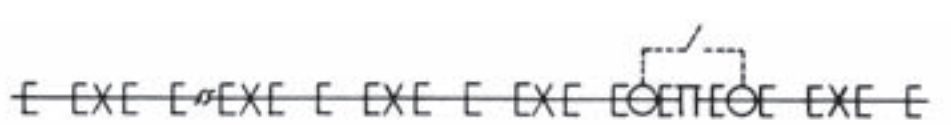
Conductor 	Feeder 	Floating Expansion Joint 
Hanger 	Anchor 	
Splice Joint 	Expansion Joint - Fixed 	Isolating Joint 
SYSTEM A — No Expansion Joint — Center Anchored		
SYSTEM B — Fixed Expansion Joint		
SYSTEM C — Floating Expansion Joint		
SYSTEM D — Isolating Joint		

GENERAL SPECIFICATIONS

The conductor-collector system shall be of the HC-Bar Composite Series as manufactured by TransTech.

Each system shall consist of necessary conductor sections, hanger supports, insulators, anchor supports, expansion joints, collectors, and/or special components as determined from plans and specifications.

The conductor shall be made of a slotted aluminum extrusion, with a steel tee section pressed into the slot. The steel and aluminum sections are fastened together at 18 inch intervals by means of steel Compression Bolts. The top of the steel tee shall serve as a flat contact service. The aluminum portion of the conductor shall have a minimum conductivity of 56%, IACS. The conductor shall have a current carrying capacity of (1000) (1250) (1500) (1750) (2000) (2500) (3000) (4000) (6000) amperes based on a 40°C rise over a 40°C ambient. The conductor shall have sufficient thermal capacity to withstand a 300% overload for intermittent duty cycles.

The hanger will be nylon coated to provide free conductor movement through the hanger to accommodate expansion or contraction of the conductor rail. Splice joints, anchors, feeders, and expansion joints shall be provided as required. The design shall be such that only bolting to the conductor is required; no drilling or welding of the rail at erection shall be necessary.

The splice joints, feeders, and expansion joints shall have an electrical efficiency of greater than 100 percent when compared by the resistance test method (NEMA SGI-5.02) to an equal length of conductor.

The temperature rise of the accessory components shall not exceed the 40°C rise of the conductor with which it is intended.

Insulators

The insulators shall be molded from fiberglass reinforced polyester material, as manufactured by TransTech.

The insulator shall have a dew flashover strength when tested per ABA Specification C29.1 of at least four (4) times normal system voltage.

The basic insulator material shall exhibit the following minimum performance levels when tested in accordance with American Society of Testing Materials Specifications. (ASTM)

Property	Minimum	ASTM No.
Dielectric Strength	400VPM	D149
Arc Track Resistance	180 Seconds	D495
Flame Retardance	Self-Exting.	D635
Heat Distortion Temp. @ 264 psi	400°F	D648
Dissipation Factor, 60 Cycle	.035	D150
Impact Strength, Ft-Lbs.	4	D256
Flexural Strength, psi	16,000	D790



System Features

Lec-Trol-Feed HD Series is a safe and efficient system for supplying power for 600 volt A.C. or 300 volt D.C. applications. Conductors can be supplied in either bronze, aluminum, or copper with respective amperage ratings of 250, 350, and 450 amps for typical installations.

Lec-Trol-Feed is designed specifically to provide maximum economy, safety and life for runway applications. Power may be taken off by means of one or more moving trolleys.

Insulated bronze, aluminum, or copper bus bars are used to carry the current. They are fully enclosed in an aluminumized steel housing with overlapping bottom safety cover which prevents accidental contact with current carrying members. Its aluminumized steel cover makes the system highly corrosion resistant. Lec-Trol-Feed may be used indoors or outdoors under most operating conditions.

The system is made up of assembled units for easy, time-saving installation in the field. The basic units include:

1. Track sections-standard expansion, sectionalizing, enclosing current carrying bus bars.
2. Accessories-coupling sets for joining track sections, feed boxes (center or end), endcaps for enclosing end of track run. Track hangers for supporting system and track anchor.
3. Trolleys-Riding on rigid bus bars provide travelling power take off.

Lec-Trol-Feed

Applications

A Lec-Trol-Feed system can serve a wide range of applications due to its safety features and simplicity. Lec-Trol-Feed supplies electrical power to move giant gantry cranes at large construction sites — heavy duty overhead cranes located inside or outside plants — special runway conveyor operations where heavy loads must be moved and other special applications.

The metal cover and safety slot feature provides safety to personnel keeping the conductor clean and dry. It withstands adverse operating conditions and still functions efficiently. Listed below are some installations where adverse operating conditions were a factor.

- Dam Site Construction — Continually exposed to falling concrete and rocks.
- Ship Yard — Defies extremely corrosive salt air.
- Steel Treating Furnace — Withstands chemicals and heat.

Advantages

Safety

Lec-Trol-Feed is designed to prevent accidental contact with current carrying bus bars.

1. Contact on top and sides prevented by steel housing.
2. Bottom safety covers — a really unique feature prevents an accidental contact from below.
3. Hazards of open systems completely eliminated.
4. You can locate system where most convenient because of built-in safety.

Dependability

These features provide greater dependability.

1. Delta-conductor arrangement gives most efficient alternating current service and greatest phase-to-phase leakage distance.
2. Unique petticoat insulator design provides maximum operating efficiency in contaminated atmospheres.

3. Trolley operation is not impaired even if steel housing has been abused.
4. Rugged trolley design.
5. Aluminized steel housing makes system highly corrosion resistant.

Installation

Save time and money because of the designed-in features.

1. Less couplings because basic track sections are 30 feet long — means less installation time.
2. Units preassembled at factory — no time used in assembling bus bars, cover, etc.
3. Ten foot hanger spacing — Fewer hangers, less installation time.
4. No expansion sections needed except at building joints — differential expansion integrally provided for.
5. Compact design allows vertical stacking.
6. No rain shields needed for outdoor applications.

Maintenance

Unique design makes every part easily and quickly accessible.

1. Removable bottom safety covers permits inspection or service of the system.
2. The trolley can be serviced or removed at any coupling section — no special door section needed.

Flexibility

Easy for you to move or modify.

1. Easy to disassemble and relocate.
2. Easy to expand or alter.
3. Safe for temporary installation.

Conductors

Track Sections

Each track section consists of an aluminized steel housing with safety cover, enclosing current bus bars and insulators which is preassembled ready for erection in the field.

Track sections are furnished in standard 30' lengths but sections in multiples of 5 feet are available to finish out intermediate runway lengths. Three types of track sections are available: plain, expansion and sectionalized.

Adjacent track sections are connected by means of a coupling set which joins the sections and maintains track alignment.

Housing

The housing consists of a top section and a removable safety cover. Housing and covers are formed of 16 gauge aluminized steel to maximum corrosion resistance and long life.

The removable safety cover sections are bolted to the top section and provide a continuous slot for the passage of the trolley arm. This assures maximum safety to personnel

Bus Bars

The C-shaped bus bars are extruded of high strength bronze, aluminum or copper alloy and represent features learned from many years of experience. Adjoining bus bars are coupled with shunted connectors which provide for full current carrying capacity across the joint and for differential expansion between bus bars and steel housing.

Bus bars are anchored at one point within each track section and expand and contract independently of the housing. Insulated sliding block assemblies or trolley wheels run along the two side bus bars. Current is collected from the vertical surface of these bus bars and the corresponding face of the upper bus bar.

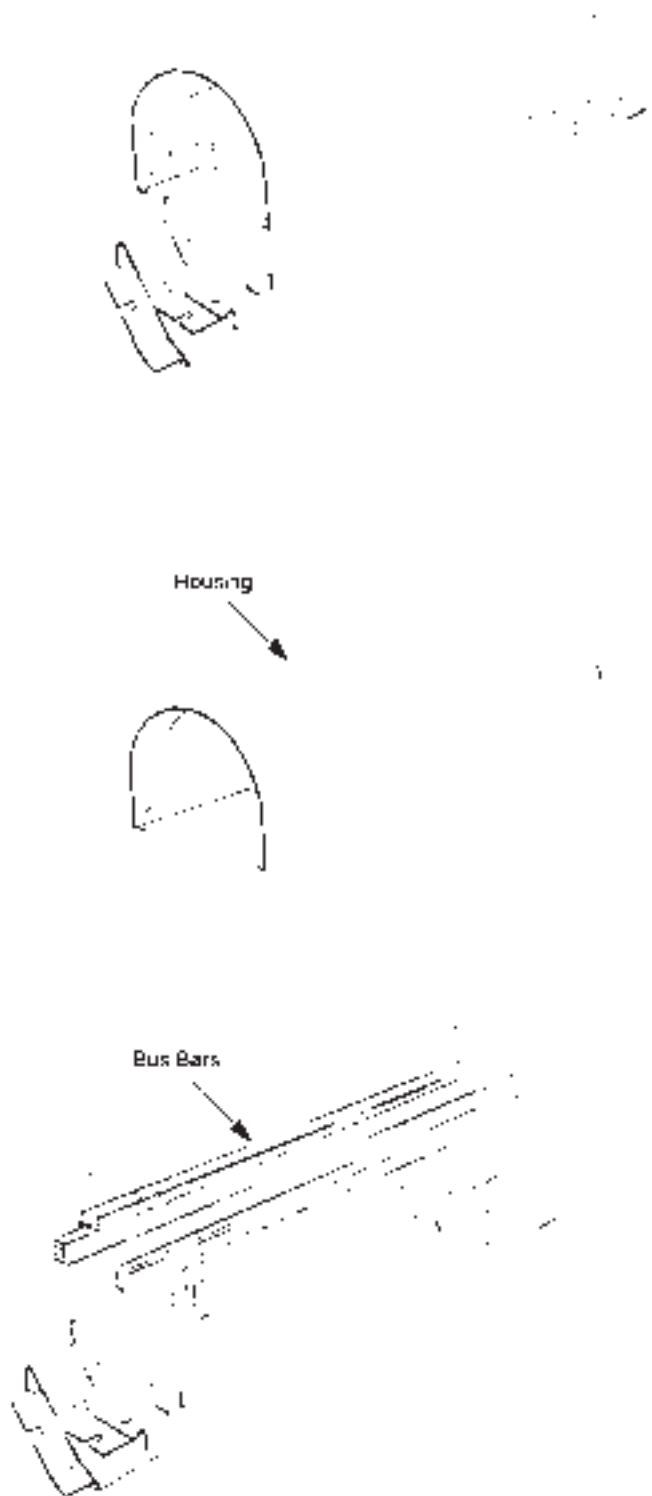

Conductors (cont.)

Insulators

The insulators are of high impact strength molded polyester fiberglass type that incorporate extra large leakage distance. Formed steel reinforcing members employed at insulator locations protect the insulators and stiffens the cover. Insulators are designed to permit longitudinal movement of bus bars independently of the covers. The bus bars are secured only at the anchor point within each track section.

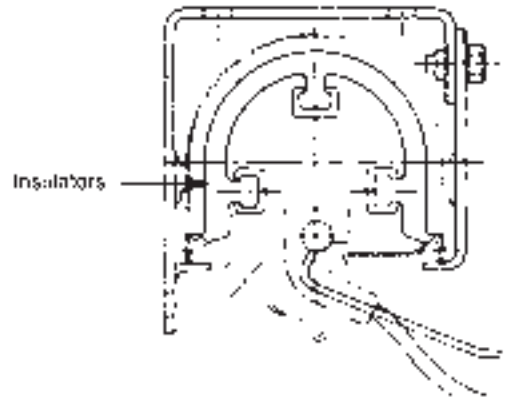

Coupling Set (Splice Joint)

The coupling set consists of a short cover section and bus bar connectors complete with copper shunts.

The coupling set cover section locks over and aligns the ends of adjacent track sections to form a continuous unbroken cover.

The bus bar connectors and copper shunts securely couple and align adjacent bus bar sections. The joint also provides for differential expansion of the bus bars. Bi-metal separators prevent galvanic action between bus bars and shunts.

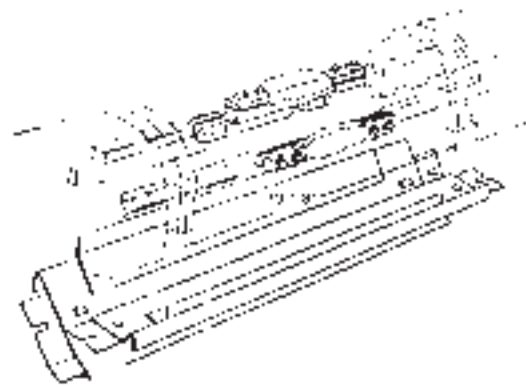

Feeder Assembly

Center Feed Box

A center feed box is required when the system is being energized at a location other than the end. The center feed box replaces a coupling set at the feed location. Feed cables are available with positive pressure type solderless connectors in lengths of 3 foot, 6 inches or 6 foot, 6 inches. The connection to the power source can be made through a 1 1/2" or 2 1/2" conduit hub plate.

End Cap Box

The end cap is made of aluminized steel and is used to enclose the end of the track run or in an end feeding system in conjunction with cables and conduit hub plate.

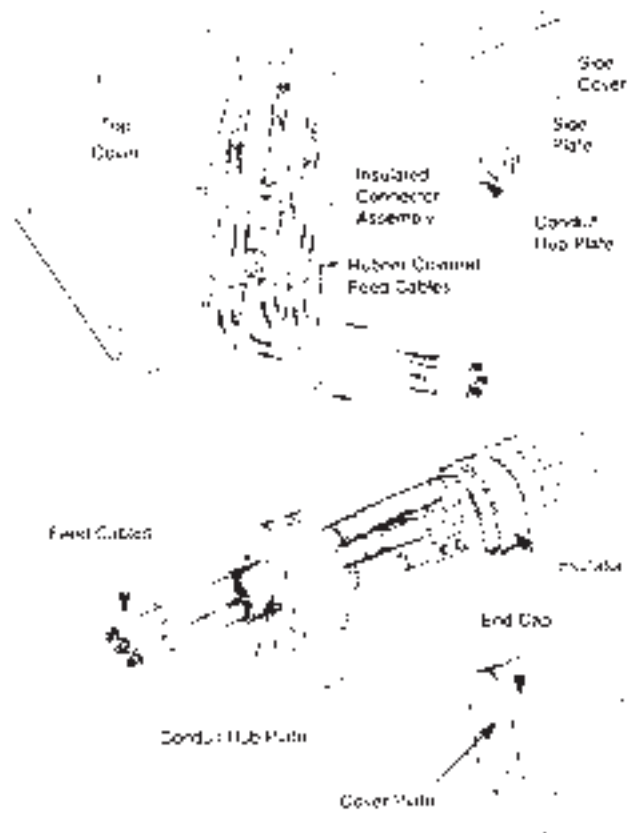

Track Hanger Set Assembly

Galvanized track hangers support the track sections from the stiff bottom edges without mechanical attachment. The hanger is made of two pieces which simplifies installation. Recommended normal installation spacing for hangers is 10 feet. The hanger attaches to either a vertical or horizontal mounting surface and the track sections are free to float in the hangers. This allows for expansion and contraction of the steel housing from point of anchorage.

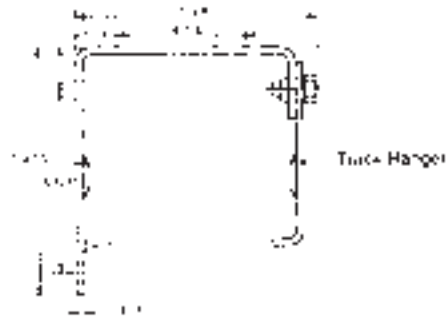

Track Anchor Assembly

The track anchor hanger is similar in design to the standard track hanger except that the anchor hanger fastens mechanically to the track sections to allow for housing expansion and contraction from this point. One track anchor hanger is furnished with each system. It should be located adjacent to the center feed box or the approximate center of the installed system in an end fed application.

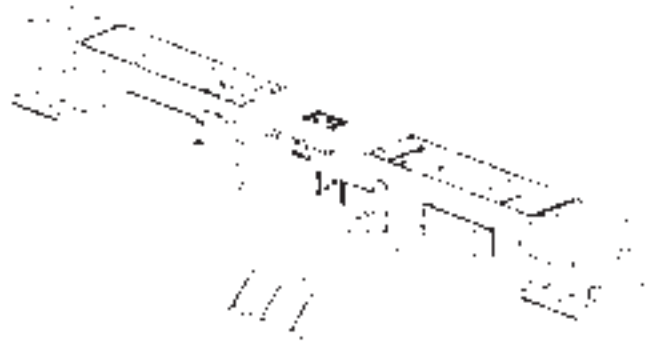

Trolley (Collector)

Trolleys for use with Lec-Trol-Feed system roll on insulated sliding block assemblies along the two side bus bars. The trolleys are constructed for dependable operation under most severe operating conditions. Current is collected with large special alloy sliding contacts from the vertical surface of the two side bus bars and the corresponding face of the upper bus bar. The trolley assemblies accommodate for misalignment in all planes.



Expansion Track Sections

The expansion track sections are sometimes required when sections must cross expansion joints in the structure. Provisions are made within each expansion section to allow for a greater amount of expansion and contraction than in a standard track section.

Flexible jumpers connect the bus bars in order to maintain the full current carrying capacity across the expansion joint. Note: On normal installation system lengths of 2000 feet indoor and 1,500 feet outdoors are permissible without expansion track sections.

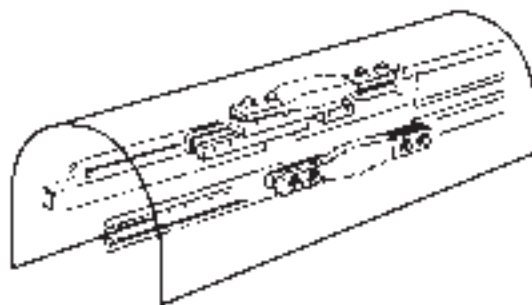

Sectionalizing Track Sections (Isolating Track)

Sectionalizing track sections are used to electrically separate adjacent track without interfering with trolley travel.

Mounting Arrangement

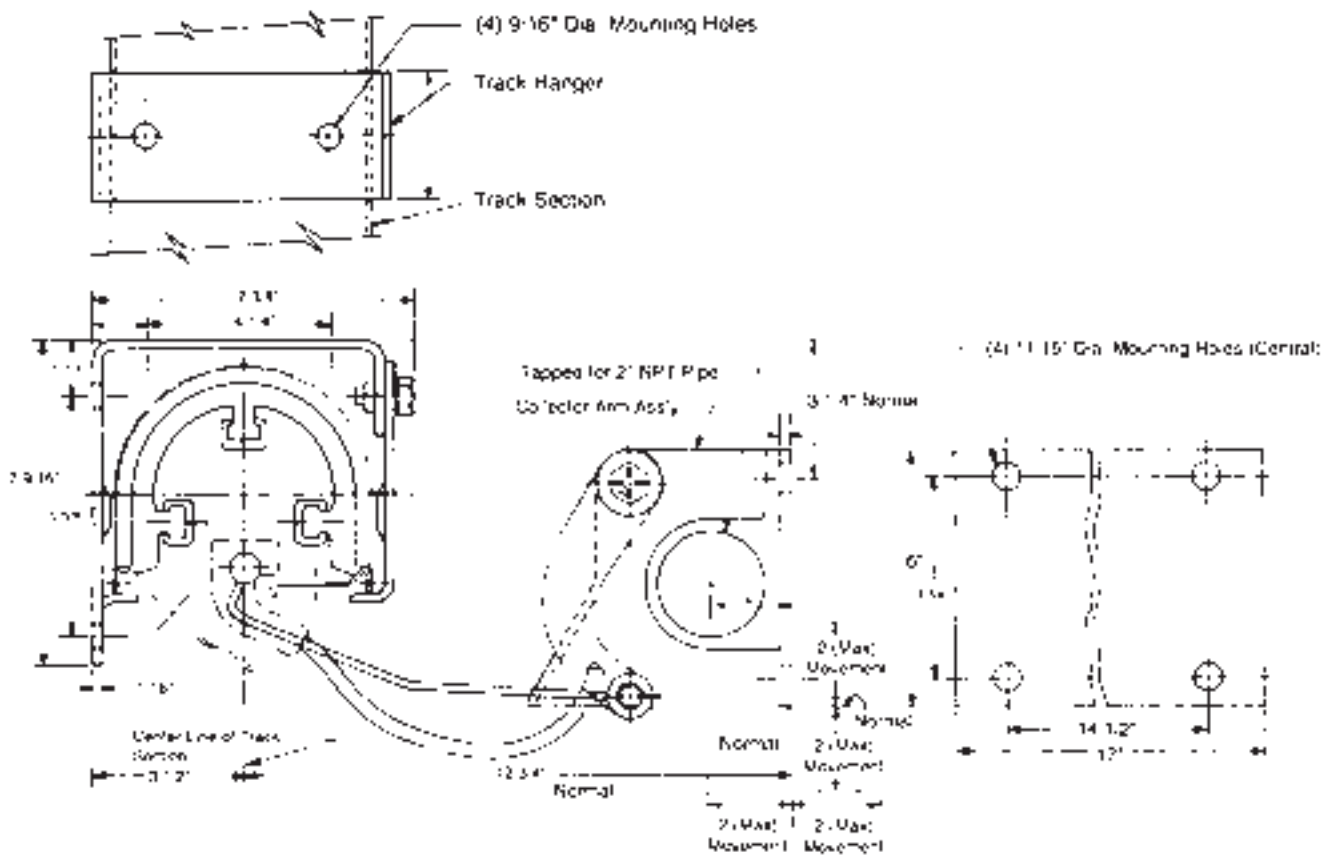

System Layout

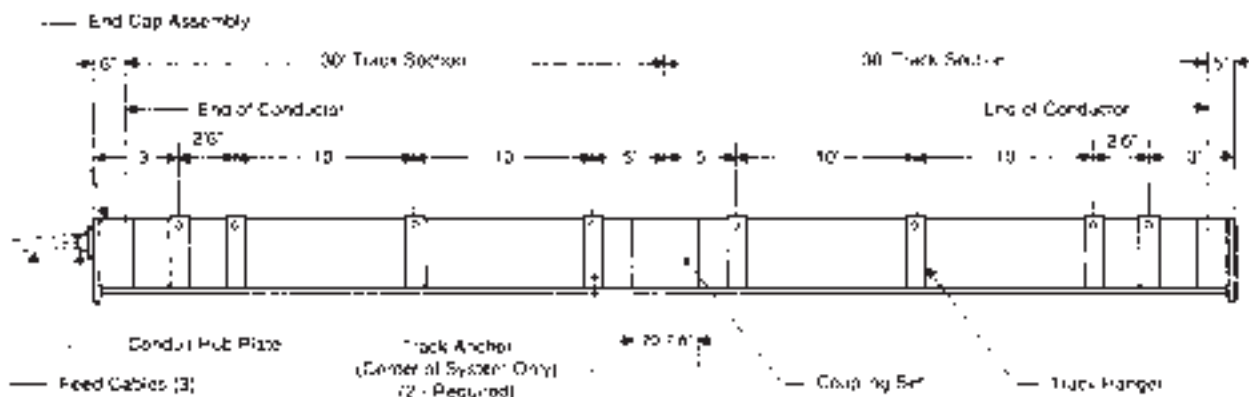

Technical Data

Voltage:

600 volts AC. -300 volts D.C.

Trolley Speed:

Maximum recommended - 600 feet/minute

Current Carrying Capacity

For typical crane, hoist, and monorail applications

Bronze Conductor250 amperes

Aluminum Conductor350 amperes

Copper Conductor450 amperes

Trolley Assembly rated at 175 amperes for use on Bronze, Aluminum or Copper Conductor.

Conductor Electrical Characteristics	Bronze	Aluminum	Copper
Electrical Conductivity %IACS @ 68° F	28	56	99
Cross Sectional Area MCM	355	457	457
D.C. Resistance OHMS/1000 feet at 68° F	.10926	.04125	.02945
A.C. Resistance OHMS/1000 feet at 68° F	.10582	.04207	.0300

A.C. Voltage Summary <i>Lec-Trol-Feed, HD Series, Three Phase 60 Cycle</i> Voltage Drop-Line to Line (Volts/100 ft.) @ Rated Current										
Load Power Factor	.1	.2	.3	.4	.5	.6	.7	.8	.9	1.0
Bronze	1.83	2.32	2.80	3.27	3.72	4.14	4.54	4.91	5.35	5.15
Aluminum	3.04	3.33	3.58	3.80	3.99	4.13	4.22	4.24	4.11	3.24
Copper	4.02	4.18	4.29	4.37	4.39	4.36	4.25	4.03	3.62	2.18

Lec-Trol-Feed Enclosed Trolley Busway System
Standard Parts

Descriptions	System						
	Bronze 250 Amp.	Net Wt. Lbs.	Aluminum 350 Amp.	Net Wt. Lbs.	Copper 450 Amp.	Net Wt. Lbs.	
Standard Track Section — Length	5'	96063	39.25	96003	29.5	96087	45.25
	10'	96062	78.5	96002	59	96086	90.5
	30'	96056	234	96001	180	96076	269
Track Hanger Set	96016	3.75	96016	3.75	96016	3.75	
Track Anchor Set	96017	3.75	96017	3.75	96017	3.75	
Coupling Set	96057	18	96009	13.5	96077	20	
End Cap Box - Right Hand	96012	7.75	96012	7.75	96012	7.75	
End Cap Box - Left Hand	96021	7.75	96021	7.75	96021	7.75	
Center Feed Box	96060	19.5	96011	15	96080	22	
Feed Cables (Center or End) 3 Required	Length 3'6"	96092	2.7	96109	4	96106	4
	6'6"	96093	5	96110	7.5	96107	7.5
	12'6"	96105	9.75	96111	14.5	96108	14.5
Conduit Hub Plate — 2 1/2"	96054	2.75	96054	2.75	96054	2.75	
Conduit Hub Plate — 1 1/2"	98673	1.75	98673	1.75	98673	1.75	
Expansion Track Section — 20'	96141	160	96014	120	96154	183	
Trolley Assembly — Complete	96018	40	96018	40	96018	40	
Collector Assembly — Only	96636	12.5	96636	12.5	96636	12.5	
Collector Arm Assembly —	96690	27	96690	27	96690	27	
Spare Parts — Sub Assemblies							
Replacement Contact Shoe	96569	.4	96569	.4	96569	.4	
Collector Arm Sub-Assy. — Right Hand	98680	3	98680	3	98680	3	
Collector Arm Sub-Assy. — Left Hand	98681	3	98681	3	98681	3	

Trolley Specifications

- The trolley busway system shall be of the metal enclosed type with internally supported conductors and trolley as manufactured by TransTech.
- The trolley busway system shall have a voltage rating of (600 Volts A.C.) (300 Volts D.C.) and a current carrying capacity of (250) (350) (450) amperes per pole of typical installations. The conductor shall be extruded of (Bronze) (Aluminum) (Copper) in a "C" configuration for high structural strength and thermal radiation ability. The full current carrying capacity of the system shall be maintained by all standard components throughout the system.
- The enclosed conductor system shall be of a design that it is suitable for outdoor applications without the use of special rain guards. The track section enclosure shall consist of a smooth rounded top housing of at least 16 gauge aluminized steel with no longitudinal breaks in the outer surface in which contamination may accumulate.
- The basic track sections shall be furnished in standard lengths of 5, 10, and 30 feet as required. The complete system shall be made up of basic 30 foot track sections insofar as possible.
- The complete system shall consist of standardized, fully interchangeable track sections, coupling sets, feed boxes, and cap assemblies, track hanger sets, track anchor hangers, and collector trolley as specified.
- Bottom safety covers shall be formed from 16 gauge minimum aluminized steel and shall be bolted to the top housing. The bottom safety covers shall be arranged in a labyrinth pattern. It shall not be possible for any object entering the slot on a straight line to contact the energized conductors.
- The conductors shall be mounted in a "D" pattern to provide minimum voltage drop. The trolley shall be guided on the conductor rails and be independent of the enclosure housing to insure that enclosure denting or externally caused damage will not affect normal trolley operation.
- All assemblies shall be preassembled by the manufacturer, requiring only matching and coupling of assemblies at the erection site.
- The conductors shall be mounted on high impact strength molded petticoat type insulators in a "D" arrangement to provide adequate leakage distance to metal parts.
- Each standard track section shall incorporate an internal anchor and expansion joint to provide for differential expansion between the conductor and enclosure.
- Expansion track sections, where required, for a building expansion joints, shall provide a range of up to four (4) inches of movement between open and closed position. The expansion track section shall be of overlapping telescopic enclosure construction permitting independent movement of the conductors and enclosure without distortion. The conductors shall provide a smooth transition contact surface for the trolley contacts. Internal flexible shunting shall provide full current capacity between the moveable sections of the conductors.
- The collector trolley shall be rated for 175 amperes nominal capacity. The trolley shall have an all insulating, fiberglass reinforced polyester chassis with insulated sliding block assemblies. The collector trolley shall be supported within and upon the "D" arranged conductors and shall be guided by insulated sliding block assemblies to prevent sleeving and maintain alignment in all planes. Trolley support and alignment shall be independent of the enclosure housing.
- The trolley shall be provided with two metal alloy graphite contacts per conductor rail to assure adequate contact area. The contacts shall be independently spring loaded to maintain constant contact pressure and alignment with the conductor rails. The trolley shall be equipped with an indexing feature to prevent incorrect installation.
- No special sections shall be required for trolley removal. The trolley and enclosure design shall be such that the collector trolley can be removed at any coupling joint between adjacent track sections.

Detailed installation instructions provided with each system when shipped.

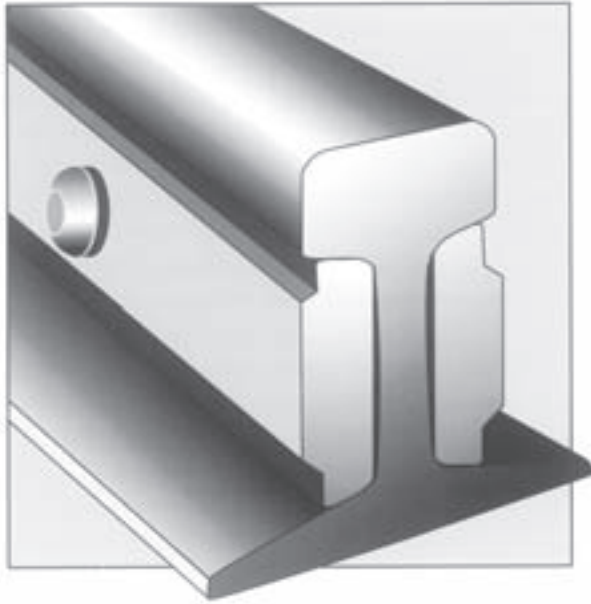

General Specifications

The conductor-collector system shall be TRANSDUCTOR as manufactured by TransTech. Each system shall consist of the necessary conductor sections; splice joints, rail support insulators, anchors, feeders, expansion joints, collectors, and/or special components as determined from plans and specifications.

The conductor shall be made of aluminum extrusions with a steel rail section. The steel and aluminum sections are fastened together at 18 inch intervals by means of steel compression bolts. The head of the steel rail shall serve as the contact surface. The aluminum portion of the conductor shall have a current carrying capacity of 1800, 2870, 4000, 6000, 8000, or 12,000 amperes based on a 40° C rise over 40° C ambient. The conductor shall have sufficient thermal capacity to withstand a 300% overload for intermittent duty cycles.

The rail support insulator will provide free conductor movement to accommodate expansion or contraction of the conductor rail. The design shall be such that only bolting of the feeders to the conductor is required; no welding of the rail at erection shall be necessary.

The splice joints, feeders and expansion joints shall have an electrical efficiency of greater than 100% when compared to an equal length of conductor.

The temperature rise of the accessory components shall not exceed the 40° C rise of the conductor with which it is intended.

Insulators shall be molded from fiberglass reinforced polyester material, as manufactured by TransTech.

The insulator shall have a dew flashover strength when tested per ASA Specification C29.1 of at least four (4) times normal system voltage.

Porcelain insulators as manufactured by TransTech shall be provided for extreme conditions such as high temperature or chemical considerations.

Terminal lugs shall be tin plated to prevent electrolytic corrosion between the aluminum and the copper alloy connector.

Transductor

Conductor

The TRANSDUCTOR® conductor is designed primarily for heavy-duty main runway electrification. It may be mounted for either overrunning or underrunning operation.

The conductor rail assembly consists of a high carbon steel rail and two aluminum extrusions. During production the steel rail is cleaned of all mill scale and foreign material. The aluminum extrusions are also cleaned to remove the aluminum oxides. The steel web of the rail is coated with an oxide inhibition compound, NO-OX-10 which creates a protective interface between the two materials. The aluminum extrusions are fastened to the steel rail by high strength steel compression bolts on 18 inch centers. Each end of the conductor assembly is factory drilled for splice bars.

Conductor sections are normally supplied in 30 or 39 foot lengths depending on the steel rail size to be used. Shorter lengths can be furnished where required.

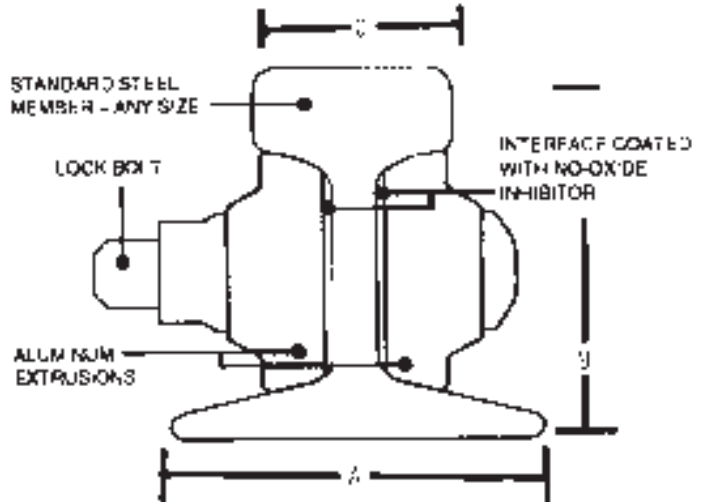

Rail Size	Current Rating	Conductor Cat. No.	D.C. Resist. Ω /1000 ft	Standard Length	Dim. A	Dim. B	Dim. C	Weight Lbs/Ft
25	1800	112147-L	0.0061	30 ft.	2 ³ / ₄	2 ³ / ₄	1 ¹ / ₂	10.7
40	2870	111593-L	0.0043	30 ft.	3 ¹ / ₂	3 ¹ / ₂	1 ⁷ / ₈	16.7
60	4000	111752-L	0.0033	30 ft.	4 ¹ / ₄	4 ¹ / ₄	2 ³ / ₈	24.3
115	6000	112377-L	0.0012	39 ft.	5 ¹ / ₂	6 ⁵ / ₈	2 ²³ / ₃₂	51.8
115	8000	112132-L	0.0009	39 ft.	5 ¹ / ₂	6 ⁵ / ₈	2 ²³ / ₃₂	56.6
115	12000	113282-L	0.0008	39 ft.	5 ¹ / ₂	6 ⁵ / ₈	2 ²³ / ₃₂	59.0

Splice Joint Assembly

The splice joint assembly connects and aligns adjoining conductor sections without drilling and welding. Simplicity of the assembly requires only standard tools. Plated steel bolts, lockwashers and nuts are employed to securely fasten two aluminum splice plates to the conductor. The aluminum splice joint has an electrical efficiency of greater than 100% when compared to an equal length of conductor. The splice joint can be used for either overrunning or underrunning operation.

Transductor	Splice Joint Cat. No.	Dim. L	Bolt Size	Weight
25-1800	112144	18 ⁷ / ₈	1/2 - 13 x 4 ¹ / ₂	10
40-2870	111595	22	1/2 - 13 x 5	11
60-4000	111753	22	5/8 - 11 x 5 1/2	13
115-6000	112133	22	3/4 - 10 x 8	34
115-8000	113307	22	3/4 - 10 x 10	44
115-12000	113283	22	3/4 - 10 x 12	53

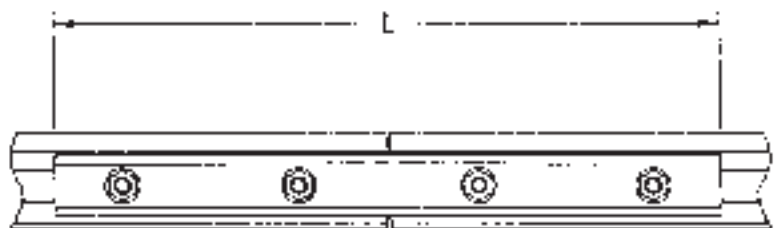

Insulator Support

The rail support insulator assembly supports and guides the Transductor®. The assembly mainly consists of an insulator, a rail base and adjustable clamps. Clamps are designed to permit free movement of the conductor to allow for expansion and contraction due to temperature changes. A two-hole mounting base is optional.

Transductor	Insul. Support Cat. No.	Figure	Dim. A	Dim. B	Wt.
25-1800	114282	1	5	2 1/2	4
40-2870	113493	1	6 1/4	3 1/2	5
60-4000	091795	1	6	3 1/2	5
115-6000	112378	2	8	5 13/16	15
115-8000	112378	2	8	5 13/16	15
115-12000	112378	2	8	5 13/16	15

Feeder Assembly

The feeder assembly provides the electrical connection from the power source to the conductor system. It may be located at any point within the system. On long systems the feeder should be located near the center of the system which reduces the effective system length, consequently reducing voltage drop. Feeders are also used in conjunction with the optional isolation joints.

Feeders should be located no closer than six inches from the nearest rail support. The assembly consists of an aluminum plate with mounting hardware to secure the assembly to the aluminum section of the conductor. Feeders will accommodate one or more terminal lugs to match the current capacity of the conductor. Feeder plates are predrilled for NEMA standard hole spacing. Terminal lugs supplied by TransTech are tin plated to reduce electrolytic corrosion between the copper alloy and aluminum feeder plate.

Transductor	Feeder Cat. No.	Figure	Dim. L	NEMA Hole Pattern	Cable Connector	Wt
25-1800	112146	3	11	(2) NEMA 4 Holes	Not Included See Page 4 & 5	5
25-1800	114222	3	11	(1) NEMA 2 Holes		5
40-2870	111598	1	12	(2) NEMA 4 Holes		4
40-2870	111649	1	16	(3) NEMA 4 Holes		6
40-2870	114041	1	8	(2) NEMA 4 Holes		3
60-4000	111755	2	6	(2) NEMA 2 Holes		3
60-4000	112159	2	16	(3) NEMA 4 Holes		6
60-4000	112161	2	10	(2) NEMA 4 Holes		5
115-12000	113285	3	16	(6) NEMA 2 Holes		28

Figure 1

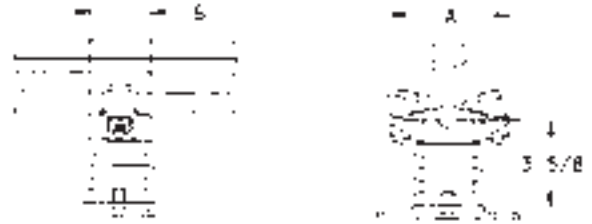

Figure 2



Figure 1



Figure 2



Figure 3

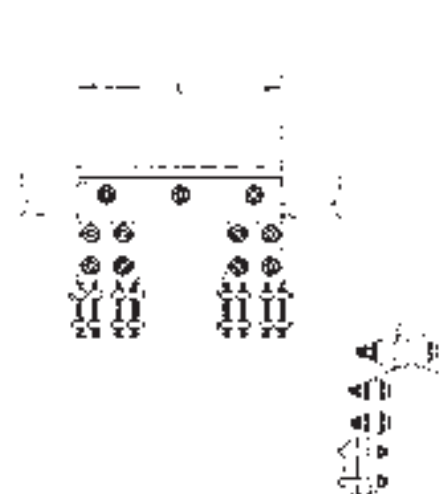

Terminal Lugs

TYPE "FU"

For Stranded Cables

The type "FU" high compression terminal lug has a longitudinal wave cast in both the body and adjustable saddle, or yoke, providing a definite wrapping action which slightly deforms the cable as the bolts are tightened. This provides positive pressure between all strands and assures a high conductivity joint with high pullout strength.

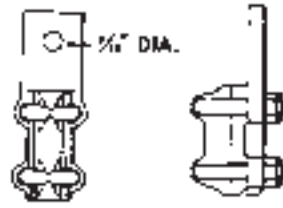
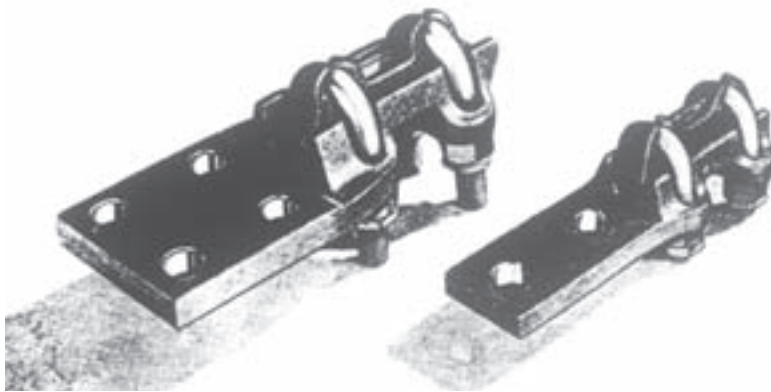

Figure 1

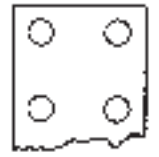

Figure 3

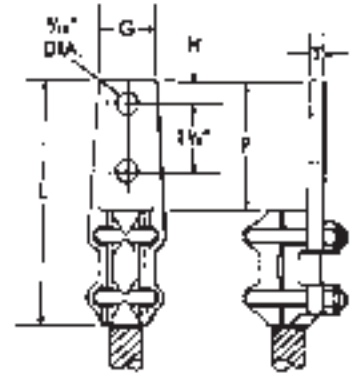

Figure 2

Cable Range		Rated Amp. Cap. of Switch	Catalog Number	Figure Number	Dimensions in Inches					U-Bolt Diameter
Min.	Max.				G	H	L	P	T	
6	2/0	200	FU-100	1	1 1/2	3/4	3 5/8	1 5/8	1/4	3/8
6	2/0	400 & 600	FU-101	2	1 1/2	5/8	5 1/4	3 1/4	1/4	3/8
1	4/0	200	FU-110	1	1 1/2	3/4	4	1 5/8	5/16	3/8
1	4/0	400 & 600	FU-111	2	1 1/2	5/8	5 1/2	3 1/8	5/16	3/8
1/0	300	200	FU-120	1	1 1/2	3/4	4 3/4	2	11/32	3/8
1/0	300	400 & 600	FU-121	2	1 1/2	5/8	5 7/8	3 1/4	11/32	3/8
1/0	300	1200	FU-122	3	3	5/8	6 1/16	3 5/16	11/32	3/8
1/0	300	2000	FU-123	3	4	1 1/8	7	4 1/4	1/4	3/8
300	500	400 & 600	FU-131	2	1 1/2	5/8	6 3/8	3 3/8	3/8	3/8
300	500	1200	FU-132	3	3	5/8	6 5/16	3 1/4	3/8	3/8
300	500	2000	FU-133	3	4	1 1/8	7 1/4	4 1/4	1/4	3/8
500	800	400 & 600	FU-140	2	1 1/2	5/8	7 1/2	3 3/4	3/8	1/2
500	800	1200	FU-141	3	3	5/8	7	3 1/4	3/8	1/2
500	800	2000	FU-142	3	4	1 1/8	8	4 1/4	3/8	1/2
750	1000	400 & 600	FU-150	2	1 1/2	5/8	7 3/4	3 3/4	3/8	1/2
750	1000	1200	FU-151	3	3	5/8	7 5/16	3 5/16	3/8	1/2
750	1000	2000	FU-152	3	4	1 1/8	8 1/4	4 1/4	7/16	1/2
1000	1500	400 & 600	FU-159	2	1 5/8	5/8	7 3/4	3 1/4	3/8	1/2
1000	1500	1200	FU-160	3	3	5/8	8	3 1/2	1/2	1/2
1000	1500	2000	FU-161	3	4	1 1/8	8 3/4	4 1/4	3/8	1/2
1500	2000	400 & 600	FU-169	2	1 1/23	5/8	7 3/4	3 1/4	1/2	1/2
1500	2000	1200	FU-170	3	3	5/8	7 3/4	3 1/4	1/2	1/2
1500	2000	2000	FU-171	3	4	1 1/8	8 3/4	4 1/4	9/16	1/2

To order connectors with all through bolts, add suffix "TB" to catalog number and note exact A.W.G. or M.C.M. size.

Terminal Lugs

TYPE "FD"

For Two Stranded Cables

Utilizing the same principals of those used in the type "FU" connectors, these twin lugs find many applications on disconnecting switches for oil circuit breakers, transformers, and similar uses. Adjustable yoke permits the use of a wide range of cable size connector.

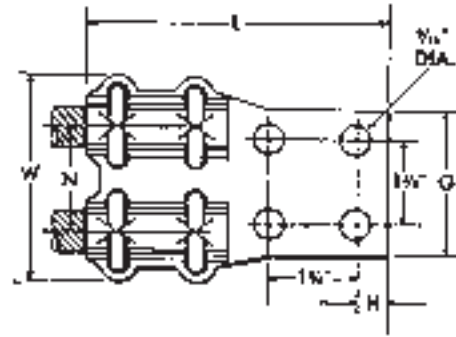

Figure 1

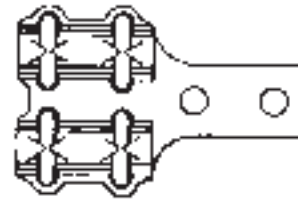
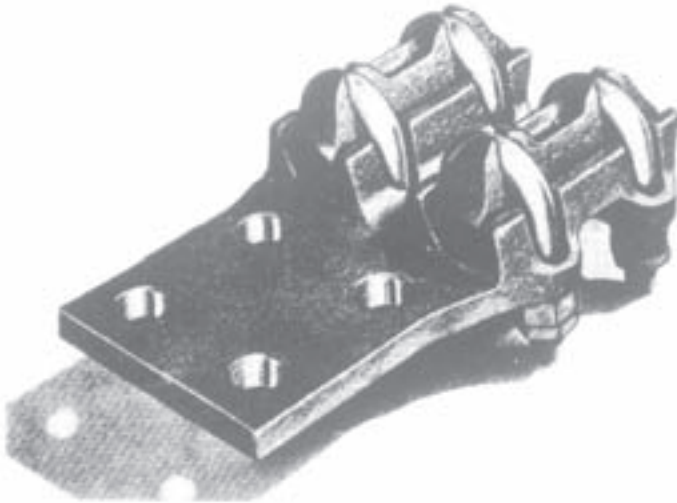
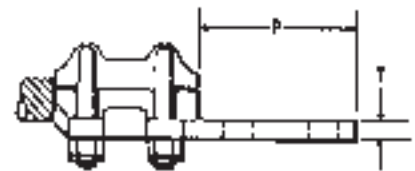

Figure 2



Cable Range		Rated Amp. Cap. of Switch	Catalog Number	Figure Number	Dimension in Inches							U-Bolt Dia.
Min.	Max.				G	H	L	N	P	T	W	
6	2/0	400 & 600	FUD-100	1	1 1/2	5/8	5 1/4	1 22/32	3 1/4	5/16	3 5/16	3/8
1	4/0	400 & 600	FUD-110	1	1 1/2	5/8	5 5/8	1 13/16	3 1/4	11/32	3 1/2	3/8
1	4/0	1200	FUD-111	2	3	5/8	5 5/8	1 13/16	3 1/4	5/16	3 1/2	3/8
1/0	300	400 & 600	FUD-120	1	1 1/2	5/8	6	2	3 1/4	3/8	3 7/8	3/8
1/0	300	1200	FUD-121	2	3	5/8	6	2	3 1/4	13/32	3 7/8	3/8
300	500	400 & 600	FUD-131	1	1 1/2	5/8	6 1/4	2 1/8	3 1/4	3/8	4 1/8	3/8
300	500	1200	FUD-132	2	3	5/8	6 1/4	2 1/8	3 1/4	3/8	4 1/8	3/8
300	500	2000	FUD-133	2	4	1 1/8	7 1/4	2 1/8	4 1/4	3/8	4 1/8	3/8
500	800	400 & 600	FUD-140	1	1 1/2	5/8	7	2 11/16	3 1/4	3/8	5 1/4	1/2
500	800	1200	FUD-141	2	3	5/8	7	2 11/16	3 1/4	7/16	5 1/4	1/2
500	800	2000	FUD-142	2	4	1 1/8	8	2 11/16	4 1/4	1/2	5 1/4	1/2
750	1000	400 & 600	FUD-150	1	1 1/2	5/8	7 1/4	2 7/8	3 1/4	7/16	5 5/8	1/2
750	1000	1200	FUD-151	2	3	5/8	7 1/4	2 7/8	3 1/4	1/2	5 5/8	1/2
750	1000	2000	FUD-152	2	4	1 1/8	8 1/4	2 7/8	4 1/4	1/2	5 5/8	1/2
1000	1500	1200	FUD-160	2	3	5/8	7 3/4	3 1/8	3 1/4	1/2	6 1/4	1/2
1000	1500	2000	FUD-161	2	4	1 1/8	8 3/4	3 1/8	4 1/4	1/2	6 1/4	1/2
1500	2000	1200	FUD-170	2	3	5/8	7 3/4	3 7/16	3 1/4	9/16	6 3/4	1/2
1500	2000	2000	FUD-171	2	4	1 1/8	8 3/4	3 7/16	4 1/4	1/2	6 3/4	1/2

To order connectors with all through bolts, add suffix "TB" to catalog number and note exact A.W.G. or M.C.M. size.

Anchor Assembly

Anchor assemblies are used at one or more points in the system to secure the conductor to a fixed point from which it can expand or contract through the rail supports. Two heavy-duty steel clip assemblies are located adjacent to a rail support to provide an anchor point in the conductor system.

Transductor	Anchor Cat. No.	Dim. A	Dim. B	Dim. C	Wt.
25-1800	112145	3 ¹ / ₁₆	5 ³ / ₈	2 ¹ / ₂	3
40-2870	111597	4 ¹ / ₄	6	3 ¹ / ₂	4
60-4000	111754	5 ³ / ₈	6 ¹ / ₂	3 ¹ / ₂	5
115-6000	114320	8 ¹ / ₂	7 ³ / ₄	5 ¹³ / ₁₆	12
115-8000	114320	8 ¹ / ₂	7 ³ / ₄	5 ¹³ / ₁₆	12
115-12000	114320	8 ¹ / ₂	7 ³ / ₄	5 ¹³ / ₁₆	12

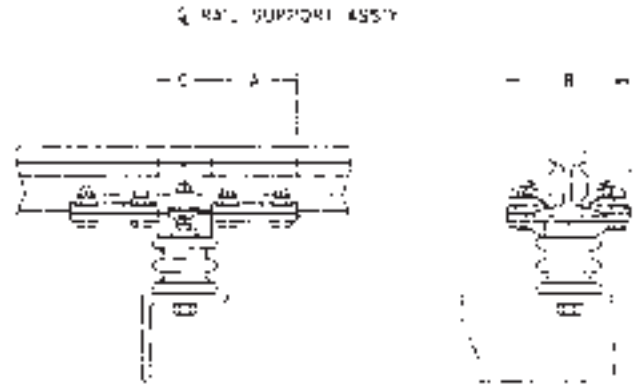

Isolating Joint Assembly

The isolating joint assembly is used to insulate adjacent conductor sections from each other without interfering with collector travel. It allows portions of the system to be electrically disconnected while operations continue on other live sections. At installations where more than one crane will be operated on a single conductor system, the isolating joint is used to create maintenance and repair bays. The isolating joint may be inserted at any point on the system in place of a standard splice joint assembly. When installed, it assures correct alignment between adjacent conductors. There are two methods of feeding the conductor system at isolation joints. (See Diagram). Each side can be fed individually through adequate safety switches or the isolation joint can be by-passed with the use of feeder assemblies and a suitable disconnect switch.



Transductor	Isolating Joint Cat. No.	Figure	Dim. L	Bolt Size	Wt.
25-1800	112158	1	20	1/2 - 13 x 4 ¹ / ₄	4
40-2870	111596	1	22	1/2 - 13 x 5	4
60-4000	111757	1	24	5/8 - 11 x 5	5
115-6000	114321	2	24	3/4 - 10 x 8	15
115-8000	114322	2	24	3/4 - 10 x 11	20
115-12000	114325	2	24	3/4 - 10 x 12	25

Expansion Joint Assembly

Expansion joints are sometimes necessary to accommodate building or support structure expansion. Normal indoor installations do not require expansion joints if the temperature ranges do not exceed 50°C. Extreme variations in temperature based on the application (Example: ladle crane, slab storage, etc.) may necessitate expansion joints and will be recommended by the factory.

Electrical continuity is provided by flexible copper shunts. Mechanical alignment across the conductor gap is maintained by sliding steel bars attached to the conductor base. The conductor gap setting is based on both the ambient temperature at the time of installation and the expected temperature variation to which the system is exposed.



Transductor	Expansion Joint Cat. No.	Dim. A	Dim. B	Dim. C	Max. System Length (ft.)		Wt.
					Indoor	Outdoor Center Anchor	
25-1800	114026	8 ¹ / ₄	8 ¹ / ₂	5 ³ / ₈	Not Required for Normal Installation	1500	27
40-2870	113494	8 ¹ / ₄	2	6		2000	30
60-4000	114324	8 ¹ / ₄	2	6 ¹ / ₂		2500	37
115-6000	113308-04	11	2	9 ¹ / ₂		2500	97
115-8000	113308-05	11	2	12		2500	124
115-12000	113308-06	11	2	14 ¹ / ₂		2500	151

Collectors

Collectors consist of an assembly of vertical mounting frame plus a spring loaded arm supporting the contact member. Adjustable spring assures proper contact with the conductor and may be varied to meet the particular working conditions.

Types LMI, LM Pony and LM Standard are assembled for either overrunning or underrunning service.

The mounting frame is provided with a corrugated surface around an elongated slot interlocking with a corrugated washer for vertical adjustment.

Feeder connections are made to a bronze solderless connector on tile mounting frame. Flexible copper cable connects the terminal lug and the contact member, thus bridging and bonding the hinged portion.

Replaceable contact members on all styles are reversible, there-by providing increased life. These contact members have a swiveling action to allow for any slight misalignment in the conductor.



LMI PONY

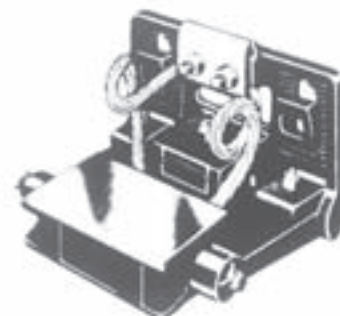

LM PONY



LM STANDARD

LMI Pony Size Collectors

Description	Extension B	Contact Member	Range		Net Wt. Each — Lbs.	Catalog Number
			Up	Down		
LMI Collector — Overrunning	7 ³ / ₈ "	88810	1 ⁵ / ₈ "	1 ⁵ / ₈ "	16	95659
LMI Collector — Underrunning	7 ³ / ₈ "	88810	1 ⁵ / ₈ "	1 ⁵ / ₈ "	16	95660
LM Pony						
LM Pony — Underrunning	4 ¹⁵ / ₁₆ "	45650	5 ⁵ / ₈ "	1"	12	98637
LM Pony — Overrunning	4 ¹⁵ / ₁₆ "	45650	1"	5 ⁵ / ₈ "	12	76512
LM Pony — Underrunning	7 ³ / ₈ "	45650	1"	1 ⁵ / ₈ "	13	98634
LM Pony — Overrunning	7 ³ / ₈ "	45650	1 ⁵ / ₈ "	1"	13	76514
LM Standard						
LM Standard — Underrunning	9 ⁵ / ₁₆ "	45715	1"	1 ¹ / ₄ "	67	45712
LM Standard — Overrunning	9 ⁵ / ₁₆ "	45715	1 ¹ / ₄ "	1"	67	76507
LM Standard — Underrunning	10 ¹³ / ₁₆ "	45715	1 ¹ / ₄ "	1 ³ / ₈ "	69	45713
LM Standard — Overrunning	10 ¹³ / ₁₆ "	45715	1 ³ / ₈ "	1 ¹ / ₄ "	69	76508
LM Standard — Underrunning	12 ⁵ / ₁₆ "	45715	1 ¹ / ₂ "	1 ³ / ₄ "	71	45714
LM Standard — Overrunning	12 ⁵ / ₁₆ "	45715	1 ³ / ₄ "	1 ¹ / ₂ "	71	76509
LM Standard — Underrunning	15 ¹ / ₁₆ "	45715	1 ⁷ / ₈ "	2 ¹ / ₂ "	75	48474
LM Standard — Overrunning	15 ¹ / ₁₆ "	45715	2 ¹ / ₈ "	2 ¹ / ₈ "	75	76510

Collectors

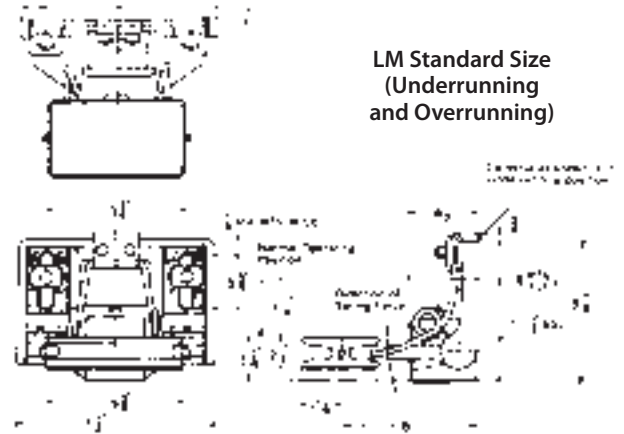
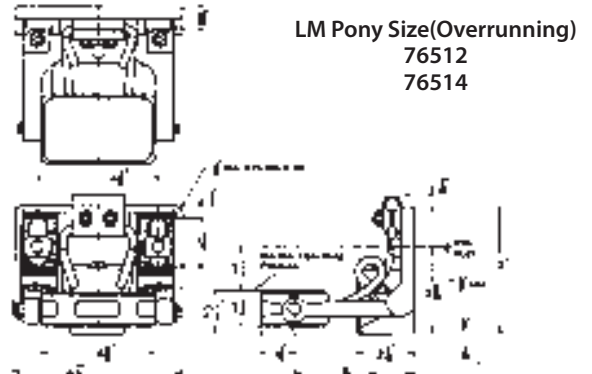
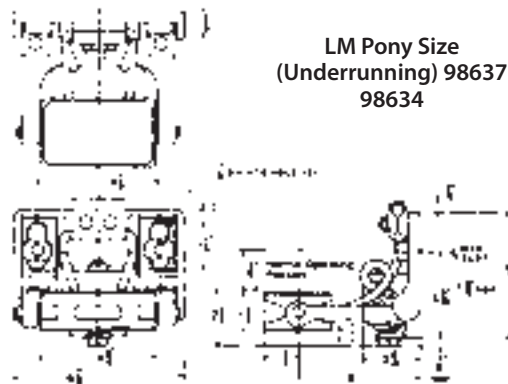
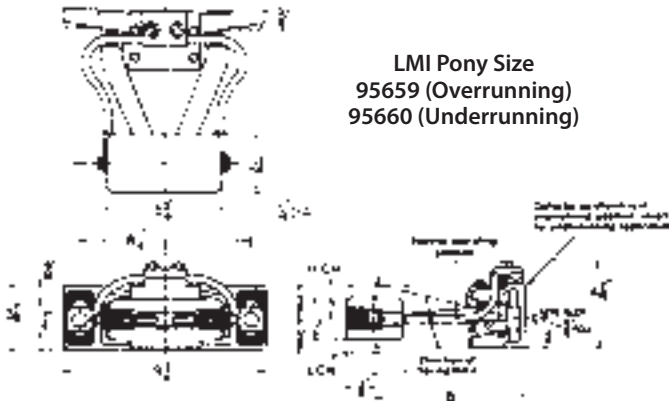

Comparison Chart			
	LMI Pony Series Page 7	LM Pony Series Page 7	LM Standard Series Page 7
Approx. Current Capacity (Amperes) Average Conditions Continuous Load Intermittent Load	250 500	250 500	550 1000
Contact Member	Contact Surface 2 1/4" x 5 9/16" Cast Iron. Copper Coated. Reversible.	Contact Surface 2 1/2" x 4 1/2" Cast Iron. Reversible.	Contact Surface 5" x 9" Cast Iron. Reversible.
Bronze Cable Terminals	Adjustable for wire diameters .414" to .528"	Adjustable for wire diameters .414" to .528"	Adjustable for wire diameters .536" to .772"
Service	Under or Overrunning	Under or Overrunning	Under or Overrunning
Height of Mounting Back	3 1/16"	5"	9 7/8"
Vertical Adjustment of Corrugated Mounting Washer	1 1/4"	1 1/4"	3"
Mounting Bolt Diam. (Not Included with Collectors)	5/8"	5/8"	3/4"
(Mounting Bolt Length Depends on Mounting conditions.) thickness of back and corrugated washer	15/16"	15/16"	1 1/2"

TECHNICAL DATA**CONDUCTOR SIZE
CALCULATION**

There are two accepted methods of determining the maximum ampere demand of one or more cranes on a single runway.

Method A

Maximum load equals the sum of all main and auxiliary hoist H.P. plus one-half ($1/2$) the sum of all bridge motor and trolley H.P.

Method B

Maximum load equals one-half ($1/2$) the sum of all motor and accessory H.P.

CALCULATION

Load H.P. (Method A or B) x amperes per H.P. (Table A) = maximum ampere demand.

Maximum ampere demand x crane factor (Table C) = adjusted maximum ampere demand.

**VOLTAGE DROP
CALCULATION****Symbols**

VL = Line Voltage at Feeder (Source).

VD = Voltage Drop.

I = Load Amperes.

L = Effective System Length in Feet. Maximum distance from feeder to end of system.

RDC = D. C. Resistance-ohms/1000 feet.

K = Voltage Drop Multiplier. A factor derived from tests which accounts for variables such as A. C. resistance, inductive reactance, power factor, phase spacing, and conductor shape factors.

Formulas

Direct Current

$$VD = \frac{ILR_{DC}}{500}$$

Alternating Current - Three Phase
(80 percent Power Factor-Flat Spacing)
VD=I L K (Line to Line*)

*For Line to Neutral Voltage Drop divide by 1.73.

Voltage Regulation

$$\% \text{ Regulation} = \frac{VD}{VL-VD} \times 100$$

TABLE A Amperes Per Horsepower Conversion		
Current	Voltage	Multiplier*
D.C.	115	8
	230	4
	600	1.6
A.C. (3 ϕ)	110	7.0
	220	3.0
	440	1.5
	550	1.2
	2300	0.25
A.C. (2 ϕ)	110	6.0
	220	2.6
	440	1.3
	550	1.1
	2300	0.21

*Average conversion factors calculated from National Electric Code Full Load Current Motor Charts. Motors built for especially low speeds or high torques may require more running current. In which case, name-plate or design current ratings should be used.

TABLE C CRANE FACTOR (C²)	
Current	Multiplier*
1	1
2	0.95
3	0.91
4	0.87
5	0.84

*In the event there are two or more cranes operating on the same load side of the feeder, the multiplying factors shown in Table C would be applied to the maximum ampere demand calculated by Method A or B.

TABLE B	
"K" Voltage loss multiplier for AC applications - Consult factory	



High Bay Reflector Bracket Assemblies For Use With Industrial Lighting Fixtures

Features

- Radius-type construction absorbs vibration, reducing lamp loosening or failures.
- Standard hook reduces possibility of fixture becoming disengaged during maintenance. Special designed safety latch provides further protection.
- Bracket hook designed to accommodate lighting fixtures of various manufacturers.

Construction

Bracket is formed from hot rolled steel in varying lengths, widths, and thicknesses depending on fixture weight and application. The safety latch is formed from spring steel, assuring constant tension against the hook. Standard hook diameter is $\frac{5}{16}$ ". After assembly, brackets are given a prime coat and a final enamel finish. Special brackets for unusual requirements are available upon request.

Method Of Mounting

Mounting installation of brackets varies according to type of structure, support beams, etc. The most common methods employ either bar clamps, bolts, or welding. Mounting accessories are not furnished with the bracket assemblies.

High-Bay

High Bay Reflector Bracket Dimensions

Single Hook with Safety Latch

Max. Wt. (Lbs.) is maximum weight of fixture supported by High Bay Reflector Bracket

Part Number	X Dim.	A Dim.	W Dim.	Radius	Size and # of Holes	B Dim.	C Dim.	Max. Wt. (Lbs.)
099791-17	1.50	12.000	.375	11.375	None	—	—	30
099791-02	1.50	12.375	.375	11.375	.563 dia. (2)	1.00	3.00	30
107293-02	1.50	12.375	.375	11.375	.563 dia. (2)	1.00	3.00	30
106207-01	1.50	13.250	.375	11.375	None	—	—	30
106700	1.50	14.250	.375	11.375	None	—	—	30
107293-03	1.50	26.000	.375	11.375	.563 dia. (2)	1.00	3.00	30
106207	1.50	30.250	.375	11.375	None	—	—	30
099791-15	1.50	26.000	.375	9.000	None	—	—	30
099791-06	1.50	12.000	.500	12.000	.563 dia. (2)	1.50	6.00	45
106208	1.50	30.250	.500	11.375	None	—	—	45
099791-03	3.00	12.375	.375	11.375	.563 dia. (2)	1.00	10.88	60
099791-11	1.75	29.500	.500	11.375	None	—	—	60
099791-01	3.00	30.250	.375	11.375	None	—	—	60
099791	3.00	30.250	.375	11.375	.563 dia. (2)	1.00	10.88	60
099791-23	3	35.000	.375	11.375	None	—	—	60
099791-22	3.00	38.250	.375	11.375	.438 dia. (2)	1.00		60
099791-05	3.00	38.250	.375	11.375	.563 dia. (2)			60
099791-20	3.00	42.250	.375	11.375	.563 slots (2)	1.50	15.00	60
099791-12	3.00	45.375	.375	11.375	None	—	—	60
107293-04	3.00	48.250	.375	11.375	None	—	—	60
099791-10	3.00	48.250	.375	11.375	None	—	—	60
099791-18	3.00	51.250	.375	11.375	None	—	—	60
107293-05	1.75	30.500	.500	12.000	.313 dia. (2)	1.50	6.00	60
107293	1.75	30.500	.500	12.000	.563 dia. (2)	1.50	6.00	60
107293-01	1.75	34.500	.500	12.000	.563 dia. (2)	1.50	6.00	60
107292-04	3.00	36.000	.375	12.000	None	—	—	60
106209	1.75	30.250	.625	11.375	None	—	—	85
106209-01	1.75	30.250	.625	11.375	.6875 dia. (2)			85
099791-16	1.75	38.000	.625	11.375	None	—	—	85
106209-02	3.00	50.000	.625	11.375	None	—	—	85
107292-05	2.50	24.000	.500	12.000	.563 dia. (2)	1.00	10.88	85
107292	2.50	24.000	.500	12.000	None	—	—	85
107292-02	2.50	30.500	.500	12.000	None	—	—	85
107292-01	2.50	36.000	.500	12.000	None	—	—	85
099791-13	1.75	30.250	.750	11.375	None	—	—	100
106210	1.75	30.250	.750	11.375	None	—	—	100
099791-09	1.75	39.250	.750	11.375	None	—	—	100
099791-19	1.75	50.000	.750	11.375	None	—	—	100
099791-07	1.75	16.250	.750	12.000	.563 dia. (2)	1.50	6.00	100
107291	1.75	18.250	.750	12.000	.563 dia. (2)	1.50	6.00	100
099791-08	1.75	22.875	.750	12.000	.563 dia. (2)	1.50	6.00	100
099791-21	1.75	41.000	.750	12.000	.563 dia. (2)	1.50	6.00	100
106211	2.00	30.250	.750	11.375	None	—	—	125
107292-03	2.00	32.000	.750	11.375	None	—	—	125
099791-04	2.00	36.000	.750	11.375	None	—	—	125
106211-01	2.00	49.875	.750	11.375	None	—	—	125
099791-14	3.00	48.250	.750	11.375	None	—	—	150



High Bay Reflector Bracket Dimensions
Double Hook with Safety Latches

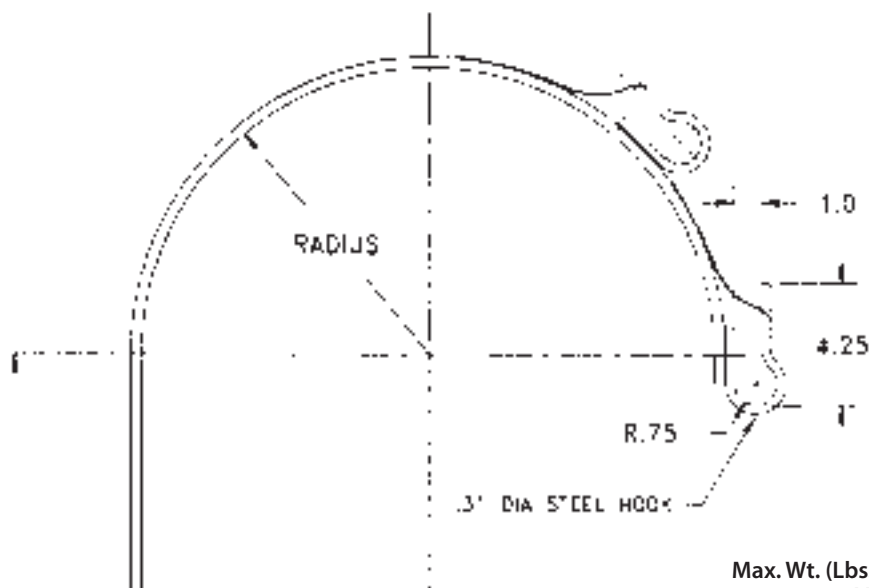

Max. Wt. (Lbs.) is maximum weight of fixture supported by High Bay Reflector Bracket

Part Number	X Dim.	A Dim.	W Dim.	Radius	Size and # of Holes	B Dim.	C Dim.	Max. Wt. (Lbs.)
108213-10	1.75	30.500	.500	12.000	.563 dia. (2)	1.50	6.00	60
108213-09	3.00	60.00	.375	10.000	.406 dia. (1)	1.00	—	65
108213-08	3.00	37.625	.375	10.000	.406 dia. (1)	1.00	—	65
108213-07	4.00	37.875	.375	11.375	.406 dia. (1)	1.00	—	65
108213-06	3.00	54.000	.375	10.000	.406 dia. (1)	1.00	—	65
108213-05	3.00	40.000	.375	10.000	.406 dia. (1)	1.00	—	65
108213-04	3.00	37.625	.375	10.000	.406 dia. (1)	1.00	—	65
113928	3.00	38.250	.375	11.375	None	—	—	65
108213-03	1.75	26.250	.750	12.000	.563 dia. (2)	1.50	6.00	100
108212-01	1.75	30.250	.750	11.375	.563 dia. (2)	1.50	6.00	100
108213-02	1.75	18.250	.750	12.000	.563 dia. (2)	1.50	6.00	100
108213-01	1.75	22.875	.750	12.000	.563 dia. (2)	1.50	6.00	100
108213	1.75	18.250	.750	12.000	.406 dia. (1)	1.00	—	100
108212	1.75	30.250	.750	11.375	.406 dia. (1)	1.00	—	100

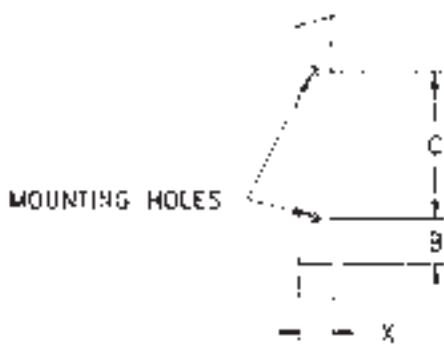
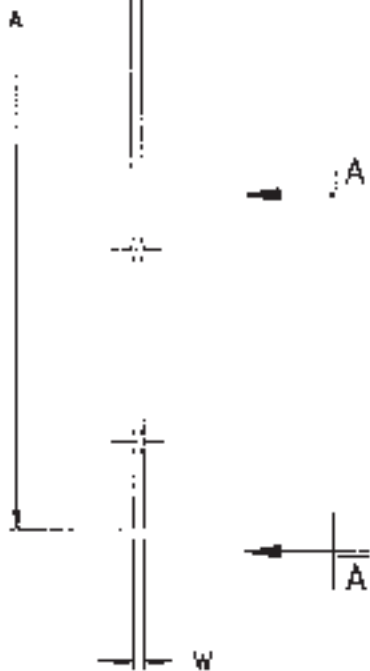

VIEW A-A

Linear Expansion

Linear expansion is an important factor; copper expands 1.11" per 100 ft. per 100°F rise, aluminum 1.54". Bus-runs should be checked to make sure that excessive stresses due to temperature changes are not transmitted to bus supports and other apparatus. With bus supports mounted on concrete or brick, the wall expansion is small, helping but little to compensate for bus expansion. Steel structures, however, expand 0.80" per 100 ft. per 100°F, compensating to some extent for bus expansion, provided the structure is subjected to as large a temperature differential as the bus. Where expansion is a factor, bus supports with roller type clamps should be used to prevent porcelain breakage. For complete protection, expansion joints should be installed. These fittings also protect against misalignment and uneven foundation settings.

Temperature Difference in Degrees Centigrade	Expansion in Inches per 100 Feet		
	Aluminum	Copper	Steel
10	.28	.20	.14
20	.55	.40	.29
30	.83	.60	.43
40	1.1	.80	.58
50	1.4	1.0	.72
60	1.7	1.2	.87
70	1.9	1.4	1.0
80	2.2	1.6	1.2
90	2.5	1.8	1.3
100	2.8	2.0	1.5

Temperature Difference in Degrees Fahrenheit	Expansion in Inches per 100 Feet		
	Aluminum	Copper	Steel
10	.15	.11	.08
20	.31	.22	.16
30	.46	.33	.24
40	.62	.44	.32
50	.77	.56	.40
60	.92	.67	.48
70	1.1	.78	.56
80	1.2	.89	.64
90	1.4	1.0	.72
100	1.5	1.1	.80
110	1.7	1.2	.88
120	1.8	1.3	.97
130	2.0	1.4	1.0
140	2.2	1.6	1.1
150	2.3	1.7	1.2
160	2.5	1.8	1.3
170	2.6	1.9	1.4
180	2.8	2.0	1.5

Reference Materials

Data Section

Properties of Copper and Aluminum		
Properties	Copper	Aluminum
Weight, pounds per cu. in.	0.322	0.098
Density, gram per cu. cm.	8.91	2.70
Specific Heat, calories per gram per °C	0.092	0.23
Melting point, °F	1981	1220
Annealing Point, °F	482	650
Modules of Elasticity	16,000,000	10,300,000
Ultimate Strength, pounds per square inch - Cast	23-26,000	11-14,000
Ultimate Strength, pounds per square inch - Annealed	28-32,000	12-15,000
Ultimate Strength, pounds per square inch - Hard Drawn Section	38-42,000	22-30,000
Ultimate Strength, pounds per square inch - Hard Drawn Wire	50-60,000	22-31,000
Length - Temperature Coefficient - Per °C	0.00001665	0.0000231
Length - Temperature Coefficient - Per °F	0.00000922	0.0000128
Thermal Conductivity, calories per sq. cm. per cm. per sec per °C	0.92	0.52
Electrical Conductivity, hard drawn, percent I.A.C.S. at 20°C	98	61
Resistance -Temperature Coefficient at 20°C for 98% copper and 61% aluminum	0.00385	0.00403
Change in Resistivity with Change in Temperature - This value is the sum of the length-temperature coefficient and the resistance-temperature coefficient, multiplied by the resistance per cm ³ at 20°C.		
Microhms per cm ³ per degree C for 98% copper and 61% aluminum	0.0068	0.0115
Resistance at 20°C for 98% copper and 61% aluminum		
One sq. cm. on cm. long (microhms)	1.7593	2.828
One sq. in. one ft. long (microhms)	8.3117	13.3606
One cir. mil. one ft. long (ohms)	10.583	17.007
(The International Copper Standard for the resistance of annealed copper of 100% conductivity at 200 is 0.15328 ohms for a uniform round wire one meter long weighing one gram. This corresponds to 8.1455 microhms for a bar of 100% conductivity copper one square inch in section by one foot long. The value 8.3117 stated above for the same size bar has been corrected for 98% conductivity.)		

**Temperature Conversion Chart
Centigrade to Fahrenheit
Formula: Degrees F = 9/5 °C. + 32**

DEG. C	0	1	2	3	4	5	6	7	8	9
	Degrees Fahrenheit									
-40	-40.0	-41.8	-43.6	-45.4	-47.2	-49.0	-50.8	-52.6	-54.4	-56.2
-30	-22.0	-23.8	-25.6	-27.4	-29.2	-31.0	-32.8	-34.6	-36.4	-38.2
-20	-4.0	-5.8	-7.6	-9.4	-11.2	-13.0	-14.8	-16.6	-18.4	-20.2
-10	+14.0	+12.2	+10.4	+8.6	+6.8	+5.0	+3.2	+1.4	-0.4	-2.2
-0	+32.0	+30.2	+28.4	+26.6	+24.8	+23.0	+21.2	+19.4	+17.6	+15.8
+0	32.0	33.8	35.6	37.4	39.2	41.0	42.8	44.6	46.4	48.2
10	50.0	51.8	53.6	55.4	57.2	59.0	60.8	62.6	64.4	66.2
20	68.0	69.8	71.6	73.4	75.2	77.0	78.8	80.6	82.4	84.2
30	86.0	87.8	89.6	91.4	93.2	95.0	96.8	98.6	100.4	102.2
40	104.0	105.8	107.6	109.4	111.2	113.0	114.8	116.6	118.4	120.2
50	122.0	123.8	125.6	127.4	129.2	131.0	132.8	134.6	136.4	138.2
60	140.0	141.8	143.6	145.4	147.2	149.0	150.8	152.6	154.4	156.2
70	158.0	159.8	161.6	163.4	165.2	167.0	168.8	170.6	172.4	174.2
80	176.0	177.8	179.6	181.4	183.2	185.0	186.8	188.6	190.4	192.2
90	194.0	195.8	197.6	199.4	201.2	203.0	204.8	206.6	208.4	210.2
100	212.0	213.8	215.6	217.4	219.2	221.0	222.8	224.6	226.4	228.2
110	230.0	231.8	233.6	235.4	237.2	239.0	240.8	242.6	244.4	246.2
120	248.0	249.8	251.6	253.4	255.2	257.0	258.8	260.6	262.4	264.2
130	266.0	267.8	269.6	271.4	273.2	275.0	276.8	278.6	280.4	282.2
140	284.0	285.8	287.6	289.4	291.2	293.0	294.8	296.6	298.4	300.2
150	302.0	303.8	305.6	307.4	309.2	311.0	312.8	314.6	316.4	318.2
160	320.0	321.8	323.6	325.4	327.2	329.0	330.8	332.6	334.4	336.2
170	338.0	339.8	341.6	343.4	345.2	347.0	348.8	350.6	352.4	354.2
180	356.0	357.8	359.6	361.4	363.2	365.0	366.8	368.6	370.4	372.2
190	374.0	375.8	377.6	379.4	381.2	383.0	384.8	386.6	388.4	390.2
200	392.0	393.8	395.6	397.4	399.2	401.0	402.8	404.6	406.4	408.2
210	410.0	411.8	413.6	415.4	417.2	419.0	420.8	422.6	424.4	426.2
220	428.0	429.8	431.6	433.4	435.2	437.0	438.8	440.6	442.4	444.2
230	446.0	447.8	449.6	451.4	453.2	455.0	456.8	458.6	460.4	462.2
240	464.0	465.8	467.6	469.4	471.2	473.0	474.8	476.6	478.4	480.2
250	482.0	483.8	485.6	487.4	489.2	491.0	492.8	494.6	496.4	498.2
260	500.0	501.8	503.6	505.4	507.2	509.0	510.8	512.6	514.4	516.2
270	518.0	519.8	521.6	523.4	525.2	527.0	528.8	530.6	532.4	534.2
280	536.0	537.8	539.6	541.4	543.2	545.0	546.8	548.6	550.4	552.2
290	554.0	555.8	557.6	559.4	561.2	563.0	564.8	566.6	568.4	570.2
300	572.0	573.8	575.6	577.4	579.2	581.0	582.8	584.6	586.4	588.2
310	590.0	591.8	593.6	595.4	597.2	599.0	600.8	602.6	604.4	606.2
320	608.0	609.8	611.6	613.4	615.2	617.0	618.8	620.6	622.4	624.2
330	626.0	627.8	629.6	631.4	633.2	635.0	636.8	638.6	640.4	642.2
340	644.0	645.8	647.6	649.4	651.2	653.0	654.8	656.6	658.4	660.2
350	662.0	663.8	665.6	667.4	669.2	671.0	672.8	674.6	676.4	678.2
360	680.0	681.8	683.6	685.4	687.2	689.0	690.8	692.6	694.4	696.2
370	698.0	699.8	701.6	703.4	705.2	707.0	708.8	710.6	712.4	714.2
380	716.0	717.8	719.6	721.4	723.2	725.0	726.8	728.6	730.4	732.2
390	734.0	735.8	737.6	739.4	741.2	743.0	744.8	746.6	748.4	750.2
400	752.0	753.8	755.6	757.4	759.2	761.0	761.8	764.6	766.4	768.2

For Interpolation:

°C	0.1	0.2	0.3	0.4	0.5	0.6	0.7	0.8	0.9	1.0
°F	0.18	0.36	0.54	0.72	0.90	1.08	1.26	1.44	1.62	1.80

Temperature Conversion Chart
Fahrenheit to Centigrade
Formula: Degrees C = 5/9 °F. - 32

DEG. F	0	1	2	3	4	5	6	7	8	9
	Degrees Centigrade									
-40	-40.0	-40.6	-41.1	-41.7	-42.2	-42.8	-43.3	-43.9	-44.4	-45.0
-30	-34.4	-35.0	-35.6	-36.1	-36.7	-37.2	-37.8	-38.3	-38.9	-39.4
-20	28.9	-29.4	-30.0	-30.6	-31.1	-31.7	-32.2	-32.8	-33.3	-33.9
-10	-23.3	-23.9	-24.4	-25.0	-25.6	-26.1	-26.7	-27.2	-27.8	-28.3
-0	-17.8	-18.3	-18.9	-19.4	-20.0	-20.6	-21.1	-21.7	-22.2	-22.8
+0	-17.8	-17.2	-16.7	-16.1	-15.6	-15.0	-14.4	-13.9	-13.3	-12.8
10	-12.2	-11.7	-11.1	-10.6	-10.0	-9.4	-8.9	-8.3	-7.8	-7.2
20	-6.7	-6.1	-5.6	-5.0	-4.4	-3.9	-3.3	-2.8	-2.2	-1.7
30	-1.1	-0.6	+0	-0.6	1.1	1.7	2.2	2.8	3.3	3.9
40	4.4	5.0	5.6	6.1	6.7	7.2	7.8	8.3	8.9	9.4
50	10.0	10.6	11.1	11.7	12.2	12.8	13.3	13.9	14.4	15.0
60	15.6	16.1	16.7	17.2	17.8	18.3	18.9	19.4	20.0	20.6
70	21.1	21.7	22.2	22.9	23.3	23.9	24.4	25.0	25.6	26.1
80	26.7	27.2	27.8	28.3	28.9	29.4	30.0	30.6	31.1	31.7
90	32.2	32.8	33.3	33.9	34.4	35.0	35.6	36.1	36.7	37.2
100	37.8	38.3	38.9	39.4	40.0	40.6	41.1	41.7	42.2	42.8
110	43.3	43.9	44.4	45.0	45.6	46.1	46.7	47.2	47.8	48.3
120	48.9	49.4	50.0	50.6	51.1	51.7	52.2	52.8	53.3	53.9
130	54.4	55.0	55.5	56.1	56.6	57.2	57.8	58.3	58.9	59.4
140	60.0	60.5	61.1	61.7	62.2	62.8	63.3	63.9	64.4	65.0
150	65.5	66.1	66.6	67.2	67.8	68.3	68.9	69.4	70.0	70.5
160	71.1	71.6	72.2	72.8	73.3	73.9	74.4	75.0	75.5	76.1
170	76.6	77.1	77.8	78.3	78.9	79.4	80.0	80.5	81.1	81.6
180	82.2	82.8	83.3	83.9	84.4	85.0	85.5	86.1	86.6	87.1
190	87.8	88.3	88.9	89.4	90.0	90.5	91.1	91.6	92.2	92.8
200	93.3	93.9	94.4	95.0	95.5	96.1	96.6	97.1	97.8	98.3
210	98.9	99.4	100.0	100.5	101.1	101.6	102.2	102.8	103.3	103.9
220	104.4	105.0	105.5	106.1	106.6	107.2	107.8	108.3	108.9	109.4
230	110.0	110.5	111.1	111.6	112.2	112.8	113.3	113.9	114.4	115.0
240	115.5	116.1	116.6	117.2	117.8	118.3	118.9	119.4	120.0	120.5
250	121.1	121.6	122.2	122.8	123.3	123.9	124.4	125.0	125.5	126.1
260	126.6	127.2	127.8	128.3	128.9	129.4	130.0	130.5	131.1	131.6
270	132.2	132.8	133.3	133.9	134.4	135.0	135.5	136.1	136.6	137.2
280	137.8	138.3	138.9	139.4	140.0	140.5	141.1	141.6	142.2	142.8
290	143.3	143.9	144.4	145.0	145.5	146.1	146.6	147.2	147.8	148.3
300	148.9	149.4	150.0	150.5	151.1	151.6	152.2	152.8	153.3	153.9
310	154.4	155.0	155.6	156.1	156.7	157.2	157.8	158.3	158.9	159.4
320	160.0	160.6	161.1	161.7	162.2	162.8	163.3	163.9	164.4	165.0
330	165.6	166.1	166.7	167.2	167.8	168.3	168.9	169.4	170.0	170.6
340	171.1	171.7	172.2	172.8	173.3	173.9	174.4	175.0	175.6	176.1
350	176.7	177.2	177.8	178.3	178.9	179.4	180.0	180.6	181.1	181.7
360	182.2	182.8	183.3	183.9	184.4	185.0	185.6	186.1	186.7	187.2
370	187.8	188.3	188.9	189.4	190.0	190.6	191.1	191.7	192.2	192.8
380	193.3	193.9	194.4	195.0	195.6	196.1	196.7	197.2	197.8	198.3
390	198.9	199.4	200.0	200.6	201.1	201.7	202.2	202.8	203.3	203.9
400	204.4	205.0	205.6	206.1	206.7	207.2	207.8	208.3	208.9	209.4

For Interpolation:

°C	0.1	0.2	0.3	0.4	0.5	0.6	0.7	0.8	0.9	1.0
°F	0.06	0.11	0.17	0.22	0.28	0.33	0.39	0.44	0.50	0.56

English-Metric Conversion Table

Inch Fraction	Inch Decimal	Millimeter	Inch Fraction	Inch Decimal	Millimeter	Inch Fraction	Inch Decimal	Millimeter
—	.003937	.1	9/32	.28135	7.1438	21/32	.65625	16.668
—	.007874	.2	19/64	.29685	7.5406	—	.669291	17.0
—	.011811	.3	5/16	.3125	7.9375	43/64	.671871	17.0656
1/64	.015625	.3969	—	.314961	8.0	11/16	.6875	17.4625
—	.015748	.4	21/64	.328125	8.3344	45/64	.703125	17.8594
—	.019685	.5	11/32	.34375	8.7313	—	.708661	18.0
—	.023622	.6	—	.354331	9.0	23/32	.718175	18.2563
—	.027559	.7	23/64	.359375	9.1281	47/64	.734375	18.6531
1/32	.03125	.7938	3/8	.375	9.525	—	.748031	19.0
—	.031496	.8	25/64	.390625	9.9219	3/4	.750	19.050
—	.03543	.9	—	.393701	10.0	49/64	.765625	19.4469
—	.03937	1.0	13/32	.40625	10.3188	25/32	.78125	19.8438
3/64	.046875	1.1906	27/64	.421875	10.7156	—	.787402	20.0
1/16	.0625	1.5875	—	.433871	11.0	51/64	.796875	20.2406
5/64	.078125	1.9844	7/16	.4375	11.1125	13/16	.8125	20.6375
—	.07874	2.0	29/64	.453125	11.5094	—	.826772	21.0
3/32	.09375	2.3813	15/32	.46875	11.9063	53/64	.828125	21.0344
7/64	.109375	2.7781	—	.472441	12.0	27/32	.84375	21.4314
—	.11811	3.0	31/64	.484375	12.3031	55/64	.859375	21.8281
1/8	.125	3.175	1/2	.500	12.700	—	.866142	22.0
9/64	.140625	3.5719	—	.511811	13.0	7/8	.875	22.225
5/32	.15625	3.9688	33/64	.515825	13.0969	57/64	.890625	22.6219
—	.15748	4.0	17/32	.53125	13.4938	—	.905512	23.0
11/64	.171875	4.3656	35/64	.546875	13.8906	29/32	.90625	23.0188
3/16	.1875	4.7625	—	.5511811	14.0	59/64	.921875	23.4156
—	.19685	5.0	9/16	.5625	14.2875	15/16	.9375	23.8125
13/64	.203125	5.1594	37/64	.578125	14.6844	—	.944882	24.0
7/32	.21875	5.5563	—	.590511	15.0	61/64	.953125	24.2094
15/64	.234375	5.9531	19/32	.59375	15.0813	31/32	.96875	24.6063
—	.23622	6.0	39/64	.609375	15.4781	—	.984252	25.0
1/4	.250	6.350	5/8	.625	15.875	63/64	.984375	25.0031
17/64	.265626	6.7469	—	.629921	16.0	1"	1.0000	25.400
—	.275591	7.0	41/64	.640625	16.2719			

The Leaders In Power Transfer Technology

TransTech is a subsidiary of Fandstan Electric, a global group of companies focusing on energy transfer systems with installations in over 100 countries. Working synergistically with our European sister companies such as Brecknell-Willis, Stemmann and AKAPP, we are able to leverage a broad product portfolio and a wealth of technical expertise. Our goal is to better serve our power transfer markets by continuing to provide solutions that improve product life, performance, and reliability.



TransTech
POWER TRANSFER SYSTEMS

709 Augusta Arbor Way
Piedmont, SC 29673

800.245.4552 ph
transtech.com

A Fandstan Electric Company