

ED Series Electric Chain Hoists

100 to 480 kgs capacity, single phase (115V) high speed portable hoist



KITO ED Series Electric Chain Hoists are engineered for light weight, high-speed lifting with the flexibility of variable speeds. ED hoists are small enough to be portable, and they feature advanced hoist technology, easy serviceability, and industry-leading quality.

FEATURES

- Load-bearing parts are only stressed to 20% of their limit at rated capacity
- Abrasion resistant, case-hardened load chain is made from heat-treated alloy steel for high, uniform strength
- Plated chain for corrosion resistance
- Forged carbon steel hook design will not fracture under excessive load
- Double braking system includes both mechanical and regenerative brakes for added safety
- Spur gears immersed in oil bath ensure quiet, smooth operation and long life
- Unique chain guide design for smooth chain travel
- Slip clutch protects the hoist against over travel and overload damage
- 360° swivel bottom hook with built-in bearing, for easy positioning
- Weathertight construction resists dust and water
- Variable high speeds up to 44 ft/min – use the best lift speed for the job
- Compact and lightweight design is ideal for use in close quarters – small enough to be portable
- Low voltage pendant control for your safety
- Tested to 125% of rated capacity



Duty Ratings	Single Speed
ASME Class	H3
Max. Starts / hr	180
%ED	35
Short Time Rating	15 min

STANDARDS

- CSA Electrical Certification
- ASME B30.16 Safety Standard
- ASME HST-1 Performance Standard
- Grade 80, Case Hardened Chain
- IP44 Environmental Protection
- DC Motor Type

OPTIONS

- Dual speed units for increased productivity
- Ergonomic cylinder control for easy one-handed operation
- Chain bag to keep chain clean and out of the way
- Custom lift lengths to suit your requirements
- Plain trolley mount for improved load control (p. 35)

ED Single/Dual Speed Hoist - Hook Mount



115
VOLTS

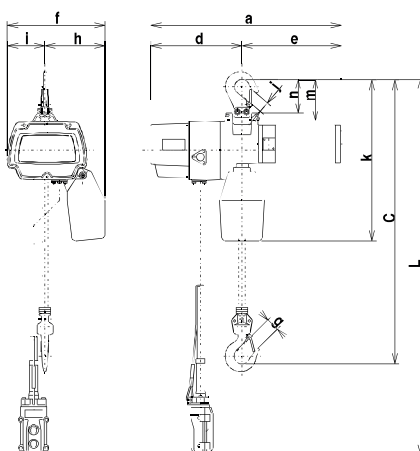

DIMENSIONS (mm)

Capacity (tonne)	Model	C	a	d	e	f	h	i	g	j	k	m	n
100 kg	EDL10S	300	371	187	184	200	120	80	27	25	340	92	73
240 kg	EDL24S	325	428	205	223	219	135	84	27	25	362	92	73
480 kg	EDL48S	520	428	205	223	229	155	74	24	24	454	149	----
100 kg	EDL10ST	300	371	187	184	200	120	80	27	25	340	92	73
240 kg	EDL24ST	325	428	205	223	219	135	84	27	25	362	92	73
480 kg	EDL48ST	520	428	205	223	229	155	74	24	24	454	149	----
100 kg	EDCL10SD	925	371	187	187	200	120	80	27	25	340	92	73
240 kg	EDCL24SD	955	428	205	223	219	135	84	27	25	362	92	73

SPECIFICATIONS

Capacity (tonne)	Model	Standard Lift (ft)	Max. Lift (ft)	Lift Speed (ft/min)	Hoist Motor H.P.	Rated Current 115V (amps)	Headroom (in)				Load Chain Code	Load Chain Falls	Ship Weight (lbs)	Weight per Additional 5 ft of Lift (lbs)	
							Hook Mount Only	Plain Trolley		Geared Trolley					
								Hook	Lug	Hook					Lug
EDL High Speed, Portable, Pendant Control, Hook Mount															
100 kg	EDL10S	10	20	43	0.4	5	12	----	9	----	----	KED040	1	25	2
240 kg	EDL24S	10	100	44	0.8	10	13	----	10	----	----	KED040	1	36	2
480 kg	EDL48S	10	50	22	0.8	10	21	23.4	----	24	----	KED040	2	49	4
EDL Dual Speed / High Speed, Portable, Pendant Control, Hook Mount															
100 kg	EDL10ST	10	20	43/10	0.4	5	12	----	9	----	----	KED040	1	27	2
240 kg	EDL24ST	10	65	44/10	0.8	10	13	----	10	----	----	KED040	1	37	2
480 kg	EDL48ST	10	32	22/6.5	0.8	10	21	23.4	----	24	----	KED040	2	49	4
EDCL Cylinder Control, Dual Speed / High Speed, Portable, Hook Mount															
100 kg	EDCL10SD	6	6	43/10	0.4	5	36	----	TBD	----	----	KED040	1	31	----
240 kg	EDCL24SD	6	6	44/10	0.8	10	38	----	TBD	----	----	KED040	1	45	----