



**Supplementary Manual
OWNER'S (OPERATOR'S) MANUAL
AND SAFETY INSTRUCTIONS
FOR KITO ELECTRIC CHAIN HOIST
ER SERIES (Model ERML)
For Capacity 7.5t to 20t
Approved by CSA**

This supplement manual includes information only for larger WLL hoists.

ALWAYS use this manual in combination with the original manual (OWNER'S (OPERATOR'S) MANUAL AND SAFETY INSTRUCTIONS FOR KITO ELECTRIC CHAIN HOIST : Bulletin No. ERM-9806-MC).

ALWAYS SAVE THIS BOOK FOR FUTURE REFERENCE.

CONTENTS

Remarks : (1) Sections written in bold type are included in this manual.

(2) Sections marked with a ☆, refer to the " Owner's (Operator's) Manual and Safety Instructions : ERM-9806-MC".

How to use this manual	1
1. DEFINITIONS	☆
2. INTENDED PURPOSE	☆
3. BEFORE USE	☆
3.1 Safety summary	☆
3.2 Safety instructions	☆
3.2.1 Before use	☆
3.2.2 While operation	☆
3.2.3 After operation	☆
3.2.4 Maintenance	☆
3.2.5 Others	☆
4. MAIN SPECIFICATIONS	1
4.1 Specifications	1
4.2 Mechanical classification (Grade) and life	☆
5. PREPARATION AND CHECKING BEFORE USE	2
5.1 Assembly of the electric chain hoist alone	2
(1) Attaching the chain container	2
(2) Lubricating the gear case	3
(3) Lubricating the load chain	☆
(4) Checking chain alignment	4
5.2 Assembly of the electric chain hoist with motorized trolley	5
(1) Attaching the chain container	5
(2) Lubricating the gear case	5
(3) Lubricating the load chain	☆
(4) Checking chain alignment	5
(5) Assembling trolley and connecting with hoist	5
(6) Mounting trolley to traversing rail	9
5.3 Wiring and installation of power supply	11
(1) Checking and changing wiring	11
(2) Wiring of power supply cable	12
(3) Installation of power supply cable	12
(4) Connection of power supply cable to electric power source	13
5.4 Trial run	☆

6. OPERATION	☆
6.1 Intended purpose of hoist operation	☆
6.2 Safety working environment	☆
6.3 Electric chain hoist	☆
6.4 Electric chain hoist with trolley	☆
6.4.1 Operation	☆
6.4.2 Precautions on usage	☆
7. MAINTENANCE	☆
7.1 Lubrication	☆
7.1.1 Gear lubrication	☆
7.1.2 Load chain lubrication	☆
7.2 Chain replacement	15
7.2.1 For WLL 7.5t or 10t(L)	15
7.2.2 For WLL of 10t(S), 15t or 20t	16
7.3 Inspection	☆
7.3.1 Inspection classification	☆
7.3.2 Daily inspection	☆
7.3.3 Periodic inspection	☆
7.3.4 Occasionally used hoists	☆
7.3.5 Inspection record	☆
7.3.6 Inspection procedure	17
8. TROUBLESHOOTING	☆
9. WARRANTY	☆

How to use this manual

This manual contains information particular to large capacity ER hoists. Be sure to use it in conjunction with the " Owner's (Operator's) Manual and Safety Instructions : ERM-9806-MC ". Where under remarks a WLL of 7.5t or larger is indicated, refer to the same numbered item in this manual.

4. MAIN SPECIFICATIONS

4.1 Specifications

The following specifications are common to an KITO electric chain hoists, model ERML larger WLL hoists from 7.5t up to 20t.

Table 4-1 Specifications

Item		Specification		
Working temperature range (°C)		-20 to + 40 (-4 to +104 °F)		
Working humidity range (%)		85 or less		
Protection	Hoist	IP 55		
	Push Button	IP 65		
Electric power supply		Three phase	60Hz	220V, 440V, 575V
Chain size	Capacity (t)	Nominal diameter (mm)		Pitch (mm)
	7.5 to 20	11.2		34.3

Remarks : (1) Contact KITO or an authorized KITO dealer for information on using the hoist beyond the working temperature or humidity range.

(2) For dimensions and other details, refer to the latest catalogue.

5. PREPARATION AND CHECKING BEFORE

5.1 Assembly of the electric chain hoist alone

⚠ WARNING

ALWAYS make sure that the supporting structures and load-attaching device are strong enough to hold the weight of the load and hoist.

(1) Attaching the chain container

The chain container stores the load chain when a load is lifted. The installation procedure is as shown in Fig. 5-1. Check that the stopper is properly attached. To place the chain in the container, feed the chain into the chain container from the end of the load chain. **NEVER** put all the load chain into the chain container at once to avoid lumping and twisting. Lumped or twisted chain may activate the limit switch and stop the hoist during lowering. Additionally, each chain container indicates the maximum length of load chain stored in the container. It is very dangerous to use a chain container with a storage capacity less than the length of the load chain. If all of the necessary chain length can not be stored in the container, the limit switch will not operate properly. Determine the required load chain length and select a chain container with proper capacity.

Remark : For the relationship between chain length and chain container, refer to the periodic inspection tables in 7.3.6 "Inspection procedure" of this "Supplement Manual (ERML-9806-MC".)

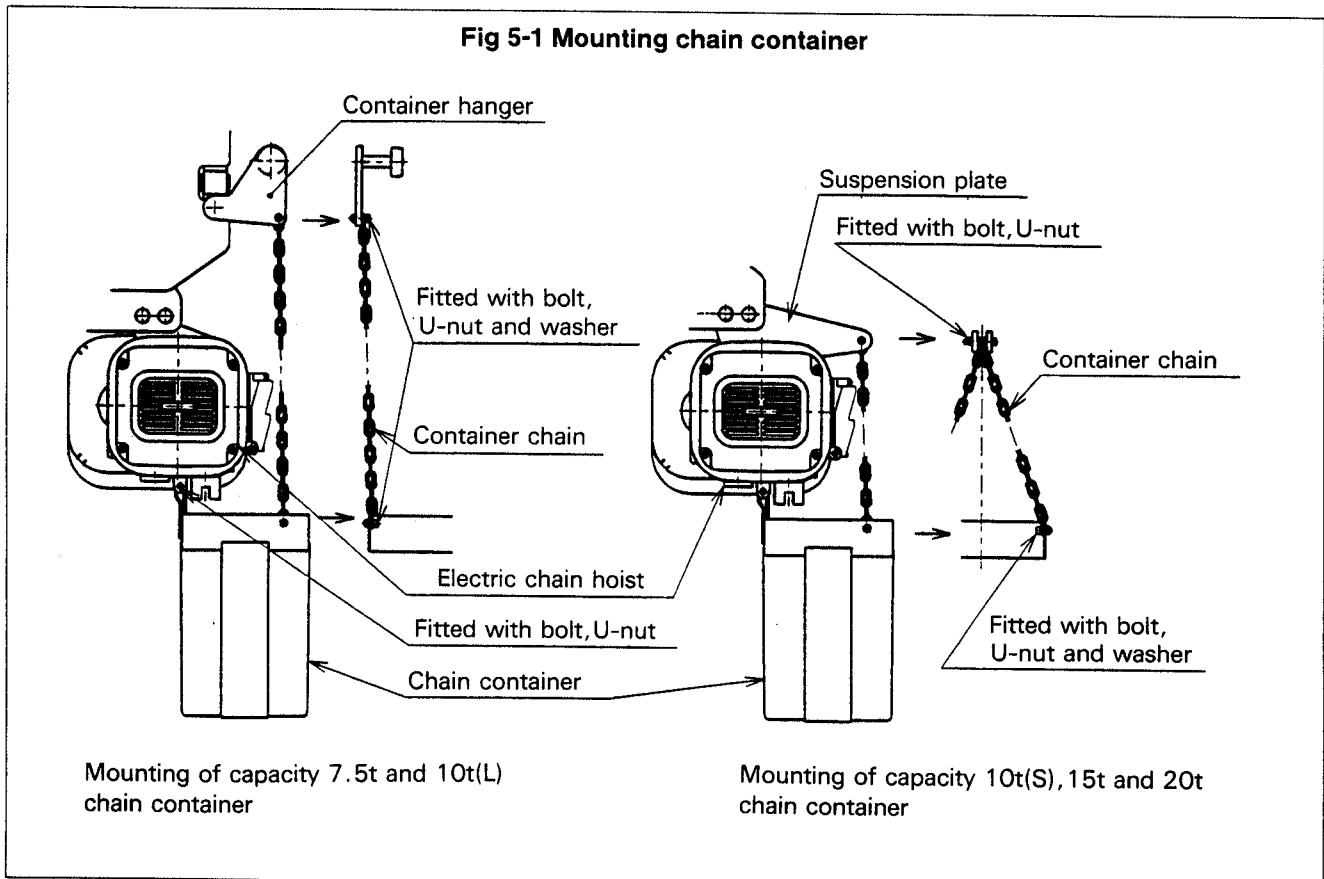

If a chain container is not used, remove the stopper from the end of the chain, and re-attach it 9th link from the end. Then attach the end link to the chain guide A as shown in Fig. 5-2.

When a chain container is used, the stopper is positioned on the third link from the end of load chain. The lift is slightly shorter when a container is not used.

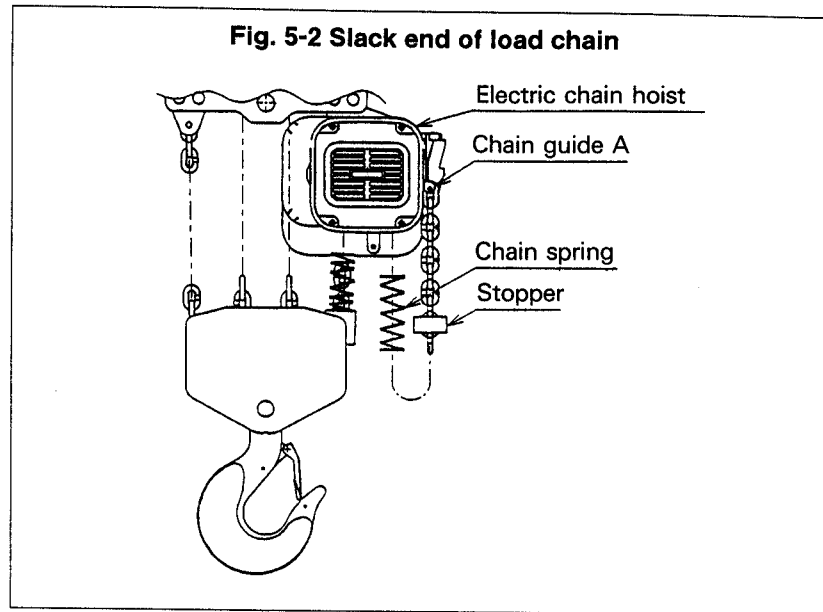

(2) Lubricating the gear case

The gear box does not contain oil at time of delivery. Remove the oil plug and pour all the gear oil, packed with the hoist, into the gear case and reinstall the oil plug. Use the specified gear oil only for the ER series and fill to the level of the oil check hole as shown below (Table 5-1, Fig. 5-3).

Table 5-1 Gear oil quantity

WLL (t)	Oil quantity
	(×NO. of bottle)
7.5,10(L)	3.0 l (1.0 l ×3)
10(S),15,20	(*) 6.0 l (1.0 l ×6)

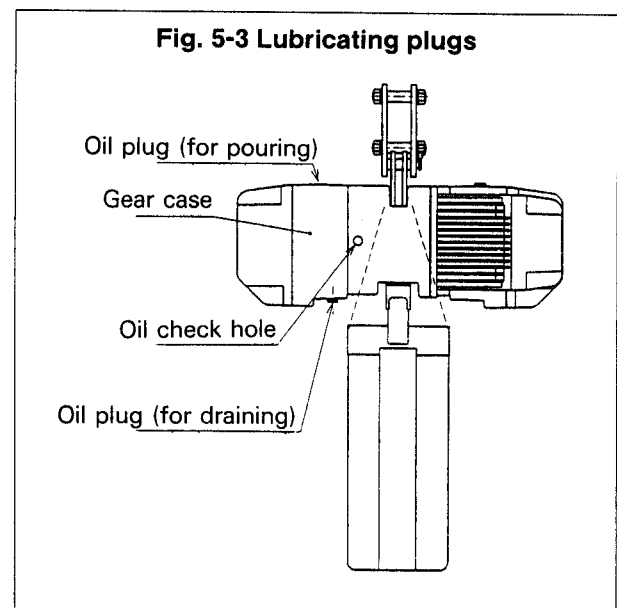

Note : (*) Indicates the amount of oil for two electric chain hoist bodies used in combination.

▲ CAUTION

Gear oil is different between friction clutch and mechanical brake combined with friction clutch (option).
Use one of the below listed gear oils.

- (1) Friction clutch
 - a) KITO standard oil : Bonnoc M260 (NIPPON OIL)
 - b) Recommended oil : Meropa 320 (TEXACO)
 - c) Recommended oil : Meropa 320 (CALTEX)
- (2) Mechanical brake combined with a friction clutch (option).
 - a) KITO standard oil : Antoil super B (NIPPON OIL)
 - b) Recommended oil : Meropa No.68 (TEXACO)

Remark : For hoist applications in temperature below -20°C (-4°F), contact KITO or an authorized KITO dealer.

(3) Lubricating the load chain

Refer to the "Owner's (Operator's) Manual and Safety Instructions : ERM-9806-MC".

(4) Checking chain alignment

Make sure that the load chain is not twisted. It is possible for the bottom hook to become capsized as shown in Fig. 5-4.

If a load chain is used in this state, it is twisted and dangerous. **NEVER** lift or lower a load with the chains twisted. Put the bottom hook in the right position by passing the hook back through the chains.

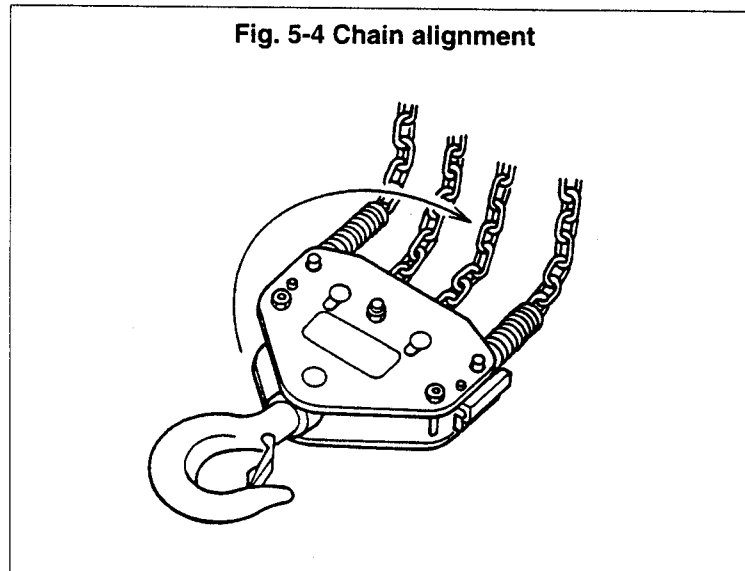

▲ CAUTION

Check for twisting in the chain.

5.2 Assembly of the electric chain hoist with motorized trolley

Refer to the "Owner's (Operator's) Manual and Safety Instructions : ERM-9806-MC".

(5) Assembling trolley and connecting with hoist

(a) Assembling trolley

- 1) Remove shaft stopper pin on the side plate S, and pull off the side plate S, adjusting spacers and the suspension plate from the suspension shaft.
- 2) Insert the required number of adjusting spacers on each side of the suspension plate (the number of inner adjusting spacers shown in Table 5-2).
- 3) Mount the side plate S and remaining spacers on the suspension shaft. Insert the shaft stopper pin into hole A in the suspension shaft as shown in Fig 5-5 and secure it with a split pin. Securely bend both branches of the split pin after insertion.

Table 5-2 Adjusting spacers arrangement on suspension shaft

		Number of Adjusting																																											
(3) WIL	Beam flange width (mm)	149	153	155	160	163	170	175	178	180	184	200	203	215	220	229	232	250	254	257	260	264	267	279	283	286	289	295	298	300	302	305													
	Parts																																												
7.5	Thin spacer	Inner	1+1	1+2	1+2	3+3	4+4	1+1	2+2	3+4	4+1	1+1	2+3	3+4	4+1	1+1	2+4	4+1	1+1	2+2	2+2	3+3	3+1	1+1	2+2	2+2	3+3	4+4	0+4	1+15	+1														
	Outer		6	5	5	3	2	0	6	5	4	3	6	5	2	0	6	5	0	6	5	4	3	2	6	5	4	3	1	4	4	3	2												
20	Thin spacer	Inner	1+1	1+1	1+1	1+1	1+1	1+1	2+2	2+2	2+2	3+3	3+3	3+3	3+3	3+1	1+1	1+1	1+1	1+1	2+2	2+2	2+2	2+2	3+3	3+3	3+3	4+3	4+3	4+3	4+3	4+3	4+3	4+3	4+3	4+3	4+3	4+3	4+3	4+3	4+3	4+3	4+3		
	Outer		4	4	4	4	4	4	2	2	2	2	0	0	0	0	5	5	5	3	3	3	3	3	1	1	1	1	1	1	1	1	1	1	1	1	1	1	1	1	1	1	1	1	
	Fixing spacer	Inner	-	-	-	-	-	-	-	-	-	-	-	-	-	-	-	-	-	-	-	-	-	-	-	-	-	-	-	-	-	-	-	-	-	-	-	-	-	-	-	-	-	-	-

Remarks : (1) Take note the numbers on spacers of inner side as follows.
Example 0+1

0 : Number on side plate S

1 : Number on side plate G

(2) Adjustment of trolley width ;

Refer to (b) of 5.2 on next page.

Adjust the dimensions by appropriately increasing or decreasing the number of inner or outer adjusting spacers, without strictly adhering to the number of adjusting spacers shown in the above table.

(3) Spacers arrangement example.

Number of Adjusting Spacers

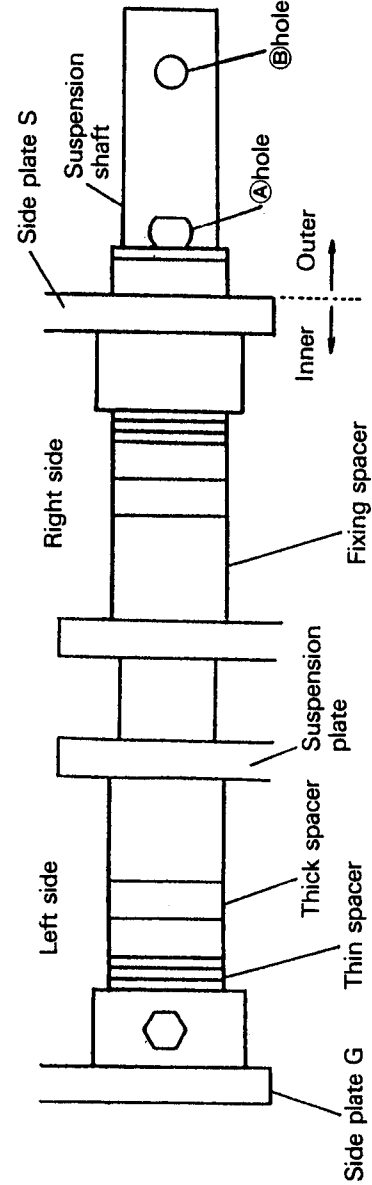
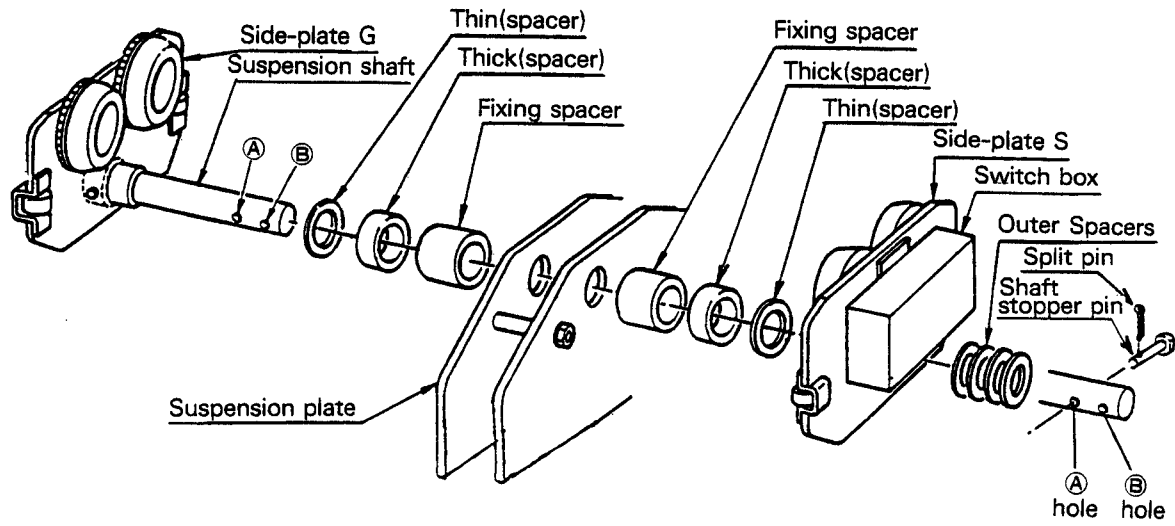

Fig. 5-5 Assembling trolley

Insert shaft stopper pin into suspension shaft from right to left, when seeing from side plate



▲ CAUTION

NEVER use the hole B for the trolley width adjustment.

(b) Adjusting trolley width

Adjust the trolley width for the proper clearance referring to Fig.5-6.

The proper "A" dimension is measured when both side plates are spread fully outward :

The "A" dimension must be :

Rail flange width (B) + 6 mm approximately

If necessary to obtain the above "A" dimension, increase or decrease the number of adjusting spacers regardless of the quantities Table 5-2.

After obtaining the proper "A" dimension, insert the split pin into the shaft stopper pin and securely bend both branches of the split pin.

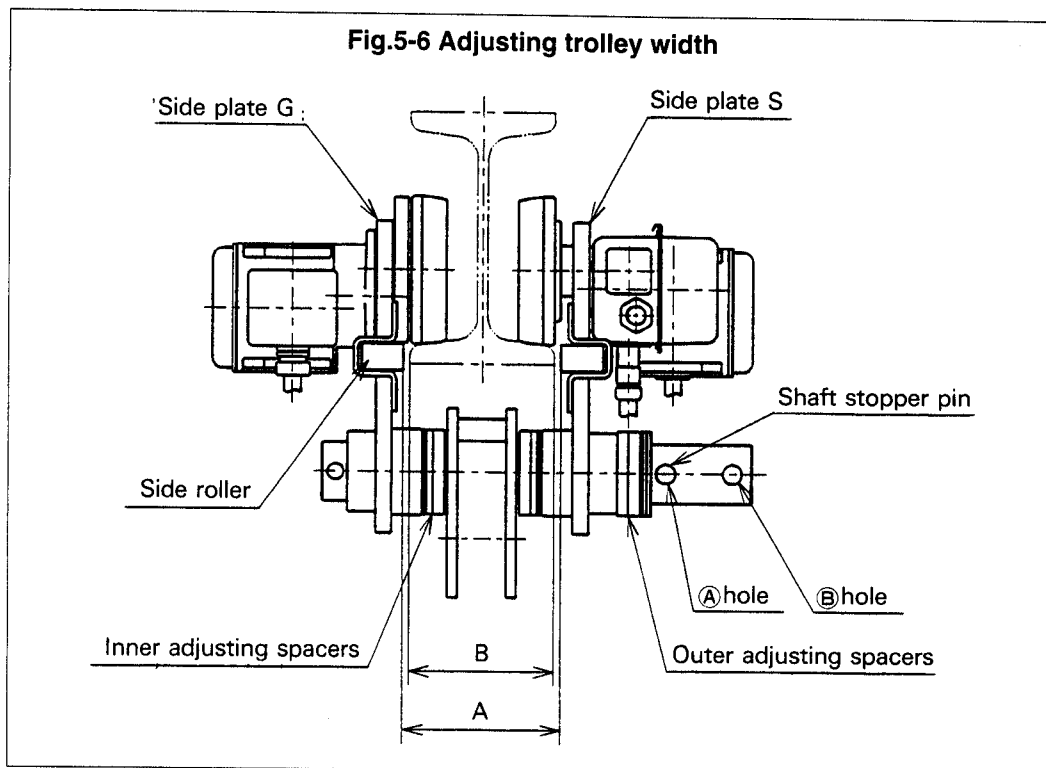

Note : Adjustment for the beam flange width shall be made within the specified number of spacers as given in Table 5-2. Consult KITO or an authorized KITO dealer for any deviation. **NEVER** use this hole B for other purpose to prevent accident with strength reason.

▲ CAUTION

The track wheels in this series of trolley are shaped differently for tapered flanges and flat flanges. Wheels for tapered flanges have a tapered tread and wheels for flat flanges have a flat tread.

Before installation, check beam flange type and wheel tread shape.

To avoid possible hazards, **NEVER** use a trolley with flat flange wheels on a tapered flange beam.

▲ WARNING

NEVER use the hole B to adjust trolley width. Hole B is to be used only for installing trolley onto the beam.

(6) Mounting trolley to traversing rail

The following explanation is for 7.5t and 10t capacity trolleys.

For 15t and 20t capacity trolleys, make adjustments and assembling work in the same way after removing the connecting plates between two trolley assemblies.

(a) Mounting on the beam

1) When the trolley can be installed from the end of the beam, with the hoist attached.

a) Remove the beam end stop from an end of the beam and mount the trolley assembly onto beam.

b) Install the beam end stop.

2) When the trolley can not be installed from the end of the beam.

▲ CAUTION

Installing the trolley as assembled with an electric chain hoist, onto the beam by separating the side plate G and S, is extremely dangerous and should not be employed under any circumstances. ALWAYS install the trolley to the beam and connect the chain hoist to the trolley.

Fig.5-7 Mounting trolley and hoist separately

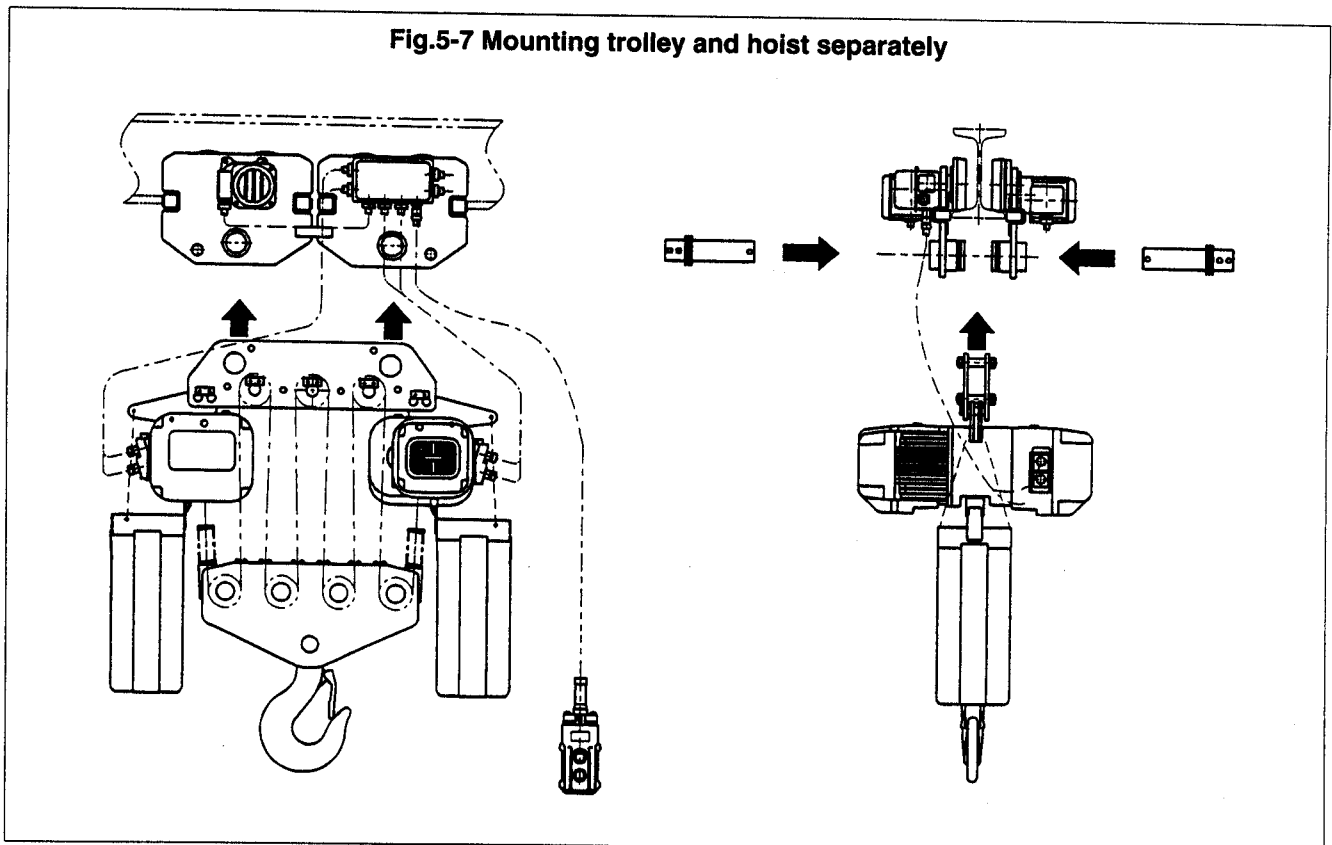

- a) Remove the connecting shaft from the chain hoist and separate the chain hoist from the trolley.
- b) Install the trolley to the beam.
 - aa) Remove the shaft stopper pin, side plate S, spacers and suspension plate from the suspension shaft.
 - bb) Mount the trolley wheels of the side plate G on the beam flange. Assemble the spacers, suspension plate, spacers and side plate S onto the suspension shaft. Push the side plate S, mount the trolley wheels of the side plate S onto the beam flange.
 - cc) Insert the shaft stopper pin into the suspension shaft and secure it with a split pin. Securely bend both branches of the split pin.
 - dd) Connect the electric chain hoist to the trolley, making sure its relative position to the trolley is correct

NEVER use this hole B for other purpose to prevent accident from strength reason.

(b) Installation of stopper onto traversing rail

Notice : If using two or more trolleys on the same beam, separate them with stoppers between every two trolleys.

The distance between stoppers depends on site requirements. Contact KITO or a KITO authorized dealer for help if required. Make sure to install stoppers at both ends of the beam.

5.3 Wiring and installation of power supply

⚠ DANGER

ALWAYS turn off the power source or breaker switch to prevent electric shock before wiring.

⚠ CAUTION

Have all wiring performed by an authorized electrician or KITO dealer.

(1) Checking and changing wiring

Check or change wiring of the electric chain hoist and motorized trolley depending on the required voltage. Make wiring referring to the following figure. In case of the equipment for 575V, It is not necessary to change those connections.

Fig.5-8

1. Motor winding

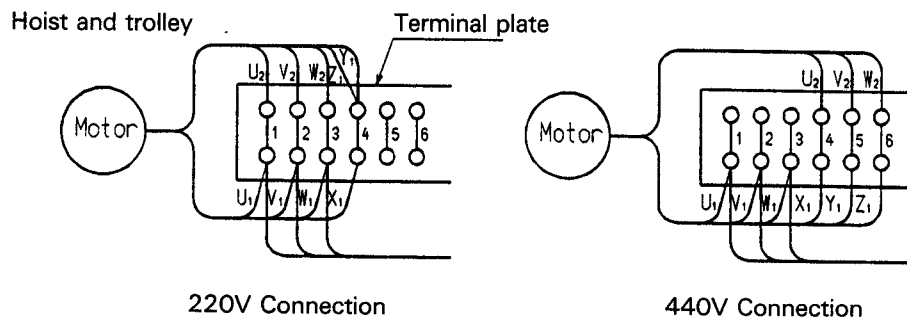

2. Transformer winding

(1) Hoist

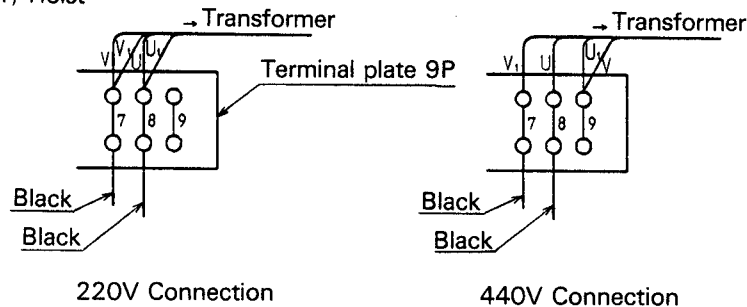

(2) Trolley

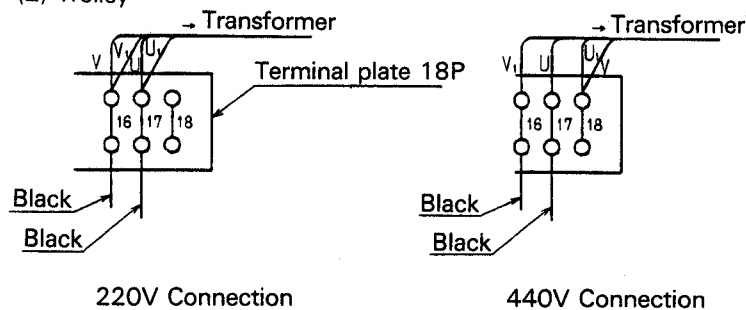

(2) Wiring of power supply cable

- ① Remove the switch box cover and switch box packing.
- ② Install firmly the cable holder to the switch box with screw.
- ③ Connect firmly red, black and blue lead wires of the cable to the terminal plate-18P referring to Fig.5-9. (Be sure to make each number of mark band of the lead wire consistently correspond to each number of the terminal plate)
- ④ The green and yellow stripped lead wire is the ground wire. Connect the wire to the ground mark of the plate firmly.
- ⑤ After checking if there is no mistake in wiring work, install the switch box packing and the cover of switch box.

Note : Refer to the wiring diagram attached on the inside of controller cover of the hoist and or the switch box cover of the motorized trolley if necessary.

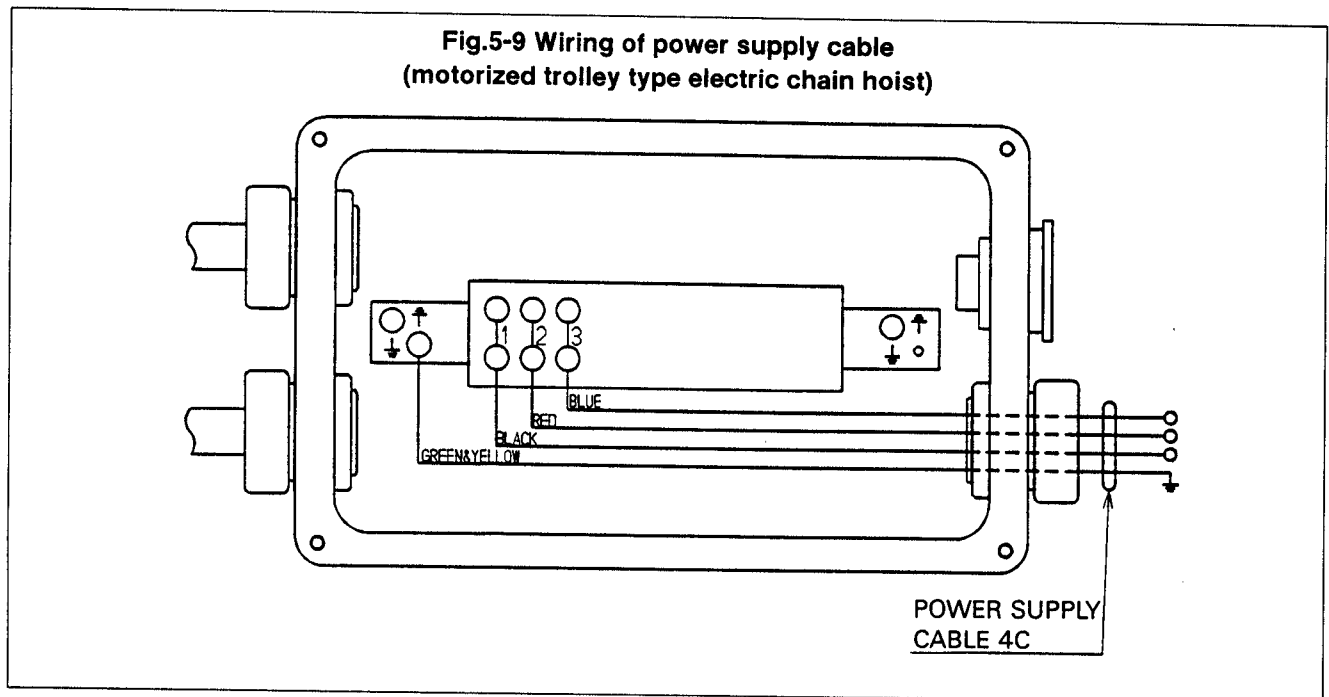

(3) Installation of power supply cable.

Install power supply cable as the following procedure.

(a) Provide messenger wire

Provide messenger wire (3 to 6 mm diameter steel cable) along the beam, make the power supply cable run with the cable hangers through the messenger wire so that it would not be twisted.

(b) Setting messenger wire to the position of wire guide (Fig 5-10)

Fit cable support to the cable support arm.

When the curved beam is used, the messenger wire can not be attached to the beam. For this case, a special T type cable hanger for the curved beam should be ordered as an optional item.

The number of special T type cable hanger and the intervals of installation depend on the position and the radius of the curve.

Therefore consult KITO dealer for this matter.

Fig.5-10

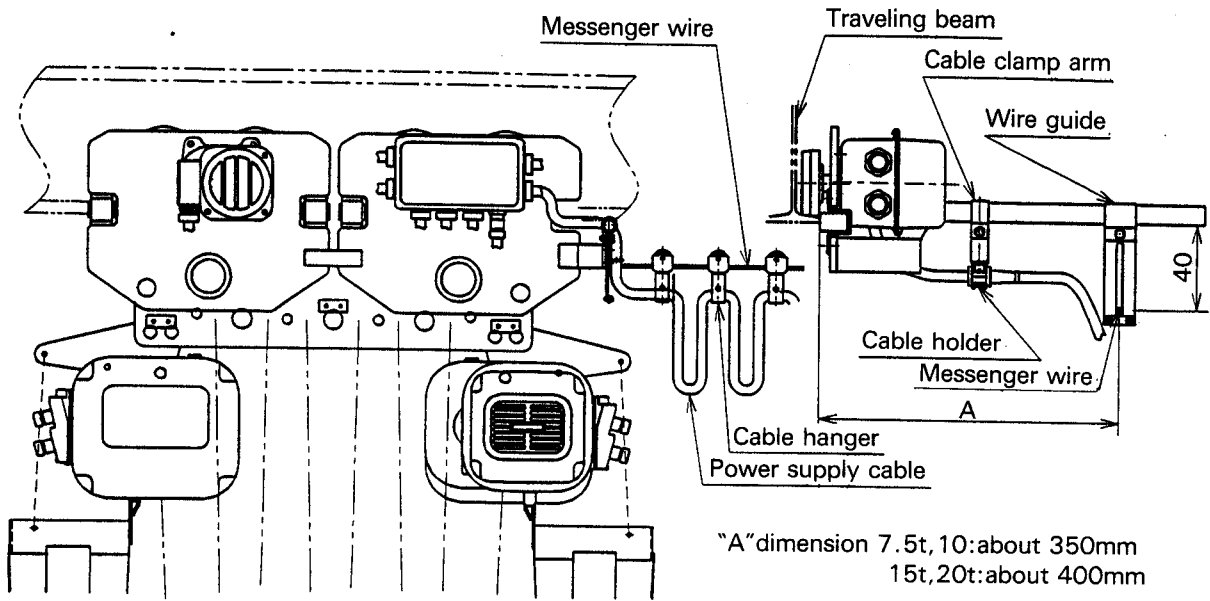

Consult KITO dealer in case the electrical power supply is by means of any other method

(4) Connection of power supply cable to electric power source

(a) Connection to electric power switch

Three wires of red, black and blue of the power supply cable should be connected to the electric power switch. Sometimes it may be required to change the connections but lead wires should be firmly connected again to the power source for better function. (See Fig. 5-11)

Fig.5-11

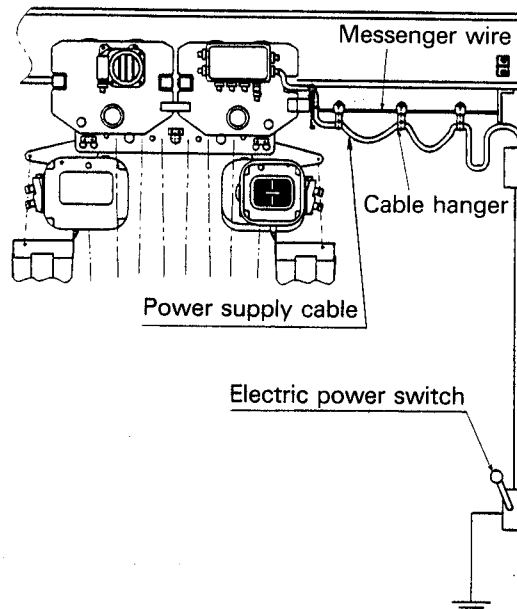

(b) Fuse and breaker capacity

The fuse and breaker should be chosen for each rated capacity shown in the following table for safety.

Table 5-3 Capacity of fuse and circuit breaker

① ER, ERSP, ERSG (single speed type)

Capacity (kg or t)	Motor output		Minimum size of wiring		Rating						Ordinary graduation of ammeter			Minimum size of ground wire	
	Lift				Fuse(A)			Breaker(A)							
	kW	HP	220/ 440V	575V	220 v	440 v	575 v	220 v	440 v	575 v	220 v	440 v	575 v	220/ 440V	575V
7.5, 10(L)	4.6	6.1	AWG 12	AWG 14	40	20	15	40	20	15	50	30	30	AWG 12	AWG 14
10(S), 15, 20	4.6×2	6.1×2	AWG 10	AWG 12	60	40	30	60	40	30	100	50	50	AWG 10	AWG 12

② ERM

Capacity (kg or t)	Motor output				Minimum size of wiring		Rating						Ordinary graduation of ammeter			Minimum size of ground wire	
	Lift		Travel				Fuse(A)			Breaker(A)							
	kW	HP	kW	HP	220/ 440V	575V	220 v	440 v	575 v	220 v	440 v	575 v	220 v	440 v	575 v	220/ 440V	575V
7.5, 10(L)	4.6	6.1	0.75	1	AWG 12	AWG 14	40	20	15	40	20	15	50	30	30	AWG 12	AWG 14
10(S), 15, 20	4.6×2	6.1×2	0.75×2	1×2	AWG 10	AWG 12	75	40	30	75	40	30	100	50	50	AWG 10	AWG 12

(c) Ground wire

The green and yellow stripped wire is the ground wire, which should always be connected to a suitable ground. Unless the wire is grounded, operator may sometimes feel a shock when touching any part of the hoist or chain.

Never paint the trolley running surface of the beam.

5.3 Trial run

Refer to the "Owner's (Operator's) Manual and Safety Instructions : ERM-9806-MC."

7.2 Chain replacement

Observe the procedure below when replacing the chain referring to Figs. 7-1 and 7-2. For WLL 7.5t and 10t(L) hoist, refer to 7.2.1, and for WLL 10t(S), 15t and 20t hoists, refer to 7.2.2.

7.2.1 WLL 7.5t and 10t(L)

- (1) Remove the stopper from the no load side.
- (2) Hook the C-link onto the end link.
- (3) Hook the end link of the new chain to the C-link.
- (4) Operate the hoist to lower the chain.
- (5) Stop lowering the chain when a sufficient amount of new chain is accumulated on the load side.
- (6) Pass the end link on the loaded side of the new chain as a standing link through both the lower and upper idle sheaves. Pull the chain until part (B) through part (A) as shown in Fig. 7-1. If the new chain on the load side is too short, lower some more chain, being careful not to twist or kink.
- (7) Remove twist in the whole load side chain and connect the end link to the chain holder of bottom hook block with a chain pin.
- (8) Attach the chain spring and stopper from the old chain to the correct link on the new chain on the no load side.

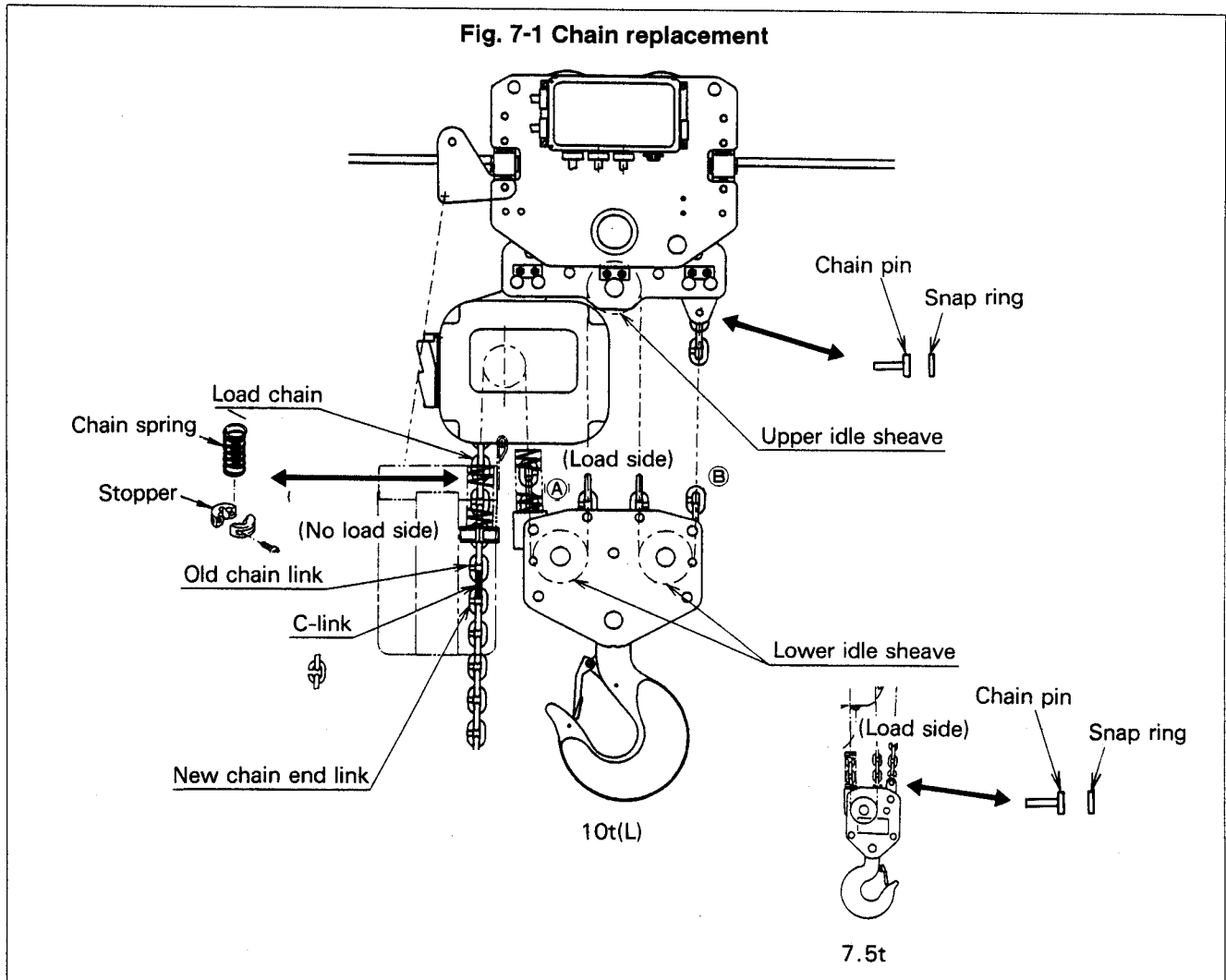

7.2.2 WLL 10t(S), 15t and 20t

- (1) Remove the stopper from the no load side.
- (2) Hook the C-link onto the end link.
- (3) Hook the end link of the new chain to the C-link.
- (4) Operate the hoist to lower the chain.
- (5) Stop lowering the chain when a sufficient amount of new chain is accumulated on the load side.
- (6) Pass the end link on the loaded side of the new chain as a standing link, through both the lower and upper idle sheaves. Pull the chain until part (B) through part (A) as shown in Fig. 7-2. If the new chain on the load side is too short, lower some more chain, being careful not to twist or kink.
- (7) Lift the hoist until enough of the new chain is drawn on the loaded side (no load side still with stopper) of the other hoist before stopping.
- (8) Attach the stoppers and chain springs from the old chain to both end links on the no load side of the new chain.
- (9) Lower both hoists till reaching each their end link.

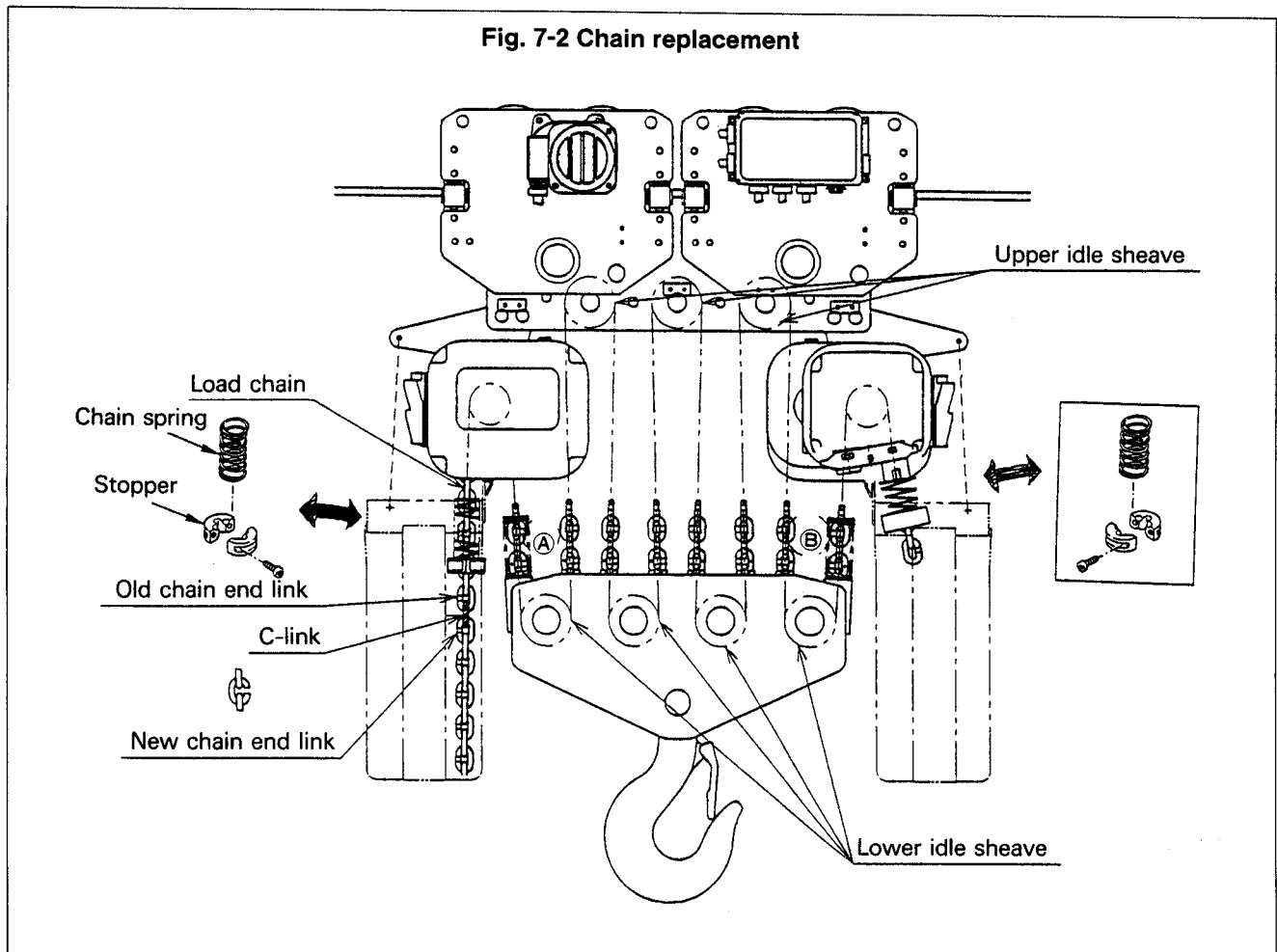

7.3 Inspection

7.3.1 Inspection classification

Refer to the "Owner's (Operator's) Manual and Safety Instructions : ERM-9806-MC "

7.3.6 Inspection procedure

Remark : Refer to this manual and 7.3.6 "Inspection procedure" in the "Owner's (Operator's) Manual and Safety Instructions : ERM-9806-MC".

(2) Periodic inspection

Class	Item	Inspection method	Discard limit/criteria	Remedy																
Hoist & Trolley	3. Power supply, ground, insulation, control circuit (1) Control circuit fuse installation and capacity	Remove the controller cover and visually check fuse installation. Check fuse capacity.	The fuse should be securely fit in the prescribed location. As indicated on the below table.	Fit in the prescribed location. Install a fuse of the proper capacity.																
					<table border="1"> <thead> <tr> <th rowspan="2">Capacity (t)</th> <th rowspan="2">Location (inside)</th> <th colspan="2">Fuse capacity (Ampere)</th> </tr> <tr> <th>ER</th> <th>ERM</th> </tr> </thead> <tbody> <tr> <td rowspan="2">7.5, 10(L)</td> <td>switch box</td> <td>.....</td> <td>2</td> </tr> <tr> <td>controller cover</td> <td>3</td> <td>3</td> </tr> <tr> <td rowspan="2">10(S), 15, 20</td> <td>switch box</td> <td>2</td> <td>2</td> </tr> <tr> <td>controller cover</td> <td>3</td> <td>3</td> </tr> </tbody> </table>	Capacity (t)	Location (inside)	Fuse capacity (Ampere)		ER	ERM	7.5, 10(L)	switch box	2	controller cover	3	3	10(S), 15, 20	switch box
Capacity (t)	Location (inside)	Fuse capacity (Ampere)																		
		ER	ERM																	
7.5, 10(L)	switch box	2																	
	controller cover	3	3																	
10(S), 15, 20	switch box	2	2																	
	controller cover	3	3																	

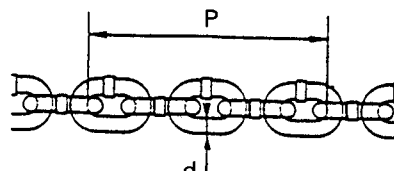
Class	Item	Inspection method	Discard limit/criteria	Remedy														
Hoist & Trolley	5. Load chain																	
	(1) Abrasion	To measure pitch with slide calipers: Measure the chain at the section that is most frequently engaged with load sheave.	Dimension (P) or (d) shall not exceed the limits presented in the table below.	If limit exceeds, ALWAYS ask the service personnel to run an inspection and replace the chain.														
																		
			<table border="1"> <thead> <tr> <th rowspan="2">Chain size (d)</th> <th rowspan="2">WLL (kg or t)</th> <th rowspan="2">Number of measured links</th> <th colspan="2">Pitch of measured links : P</th> <th rowspan="2">Discard limit of (d)</th> </tr> <tr> <th>Standard</th> <th>Limit</th> </tr> </thead> <tbody> <tr> <td>11.2</td> <td>7.5, 10(L) 10(S), 15, 20</td> <td>3</td> <td>102.6</td> <td>105.6</td> <td>10.1</td> </tr> </tbody> </table>	Chain size (d)	WLL (kg or t)	Number of measured links	Pitch of measured links : P		Discard limit of (d)	Standard	Limit	11.2	7.5, 10(L) 10(S), 15, 20	3	102.6	105.6	10.1	
Chain size (d)	WLL (kg or t)	Number of measured links	Pitch of measured links : P				Discard limit of (d)											
			Standard	Limit														
11.2	7.5, 10(L) 10(S), 15, 20	3	102.6	105.6	10.1													

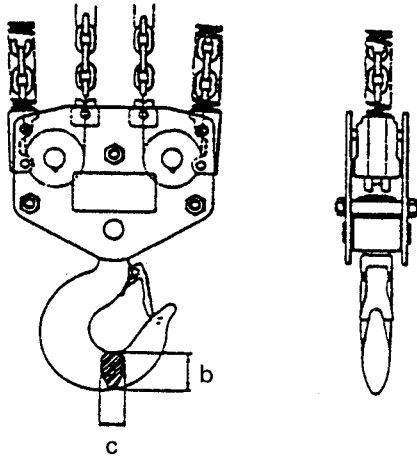
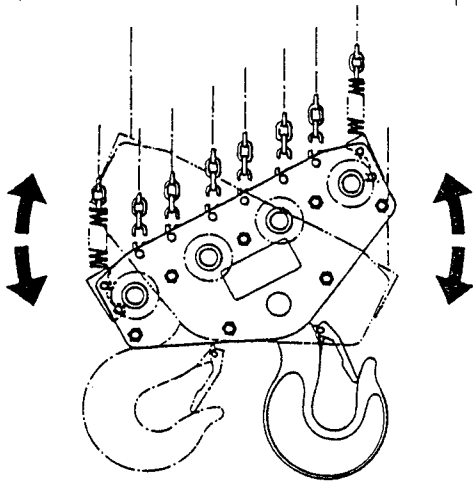
Class	Item	Inspection method	Discard limit/criteria	Remedy																							
Hoist & Trolley	(2) Hook wear	Measure "b" and "c" with slide calipers.	NEVER use the hook if dimension "b" or "c" becomes less than 90% of normal.	Replace with new hook if worn.																							
			 <table border="1" data-bbox="799 851 1474 1027"> <thead> <tr> <th rowspan="2">WLL (kg or t)</th> <th colspan="2">b(mm)</th> <th colspan="2">c(mm)</th> </tr> <tr> <th>Normal</th> <th>Discard</th> <th>Normal</th> <th>Discard</th> </tr> </thead> <tbody> <tr> <td>7.5, 10(L), 10(S)</td> <td>73</td> <td>66</td> <td>48</td> <td>43</td> </tr> <tr> <td>15</td> <td>87</td> <td>78</td> <td>60</td> <td>54</td> </tr> <tr> <td>20</td> <td>99.5</td> <td>90</td> <td>70</td> <td>63</td> </tr> </tbody> </table>	WLL (kg or t)	b(mm)		c(mm)		Normal	Discard	Normal	Discard	7.5, 10(L), 10(S)	73	66	48	43	15	87	78	60	54	20	99.5	90	70	63
WLL (kg or t)	b(mm)		c(mm)																								
	Normal	Discard	Normal	Discard																							
7.5, 10(L), 10(S)	73	66	48	43																							
15	87	78	60	54																							
20	99.5	90	70	63																							
	(6) Rotation of idle sheave	Turn idle sheave by lifting the load chain up and down, as illustrated.	The idle sheave rotates smoothly.	Inspect and repair if rotation is not smooth.																							
																											

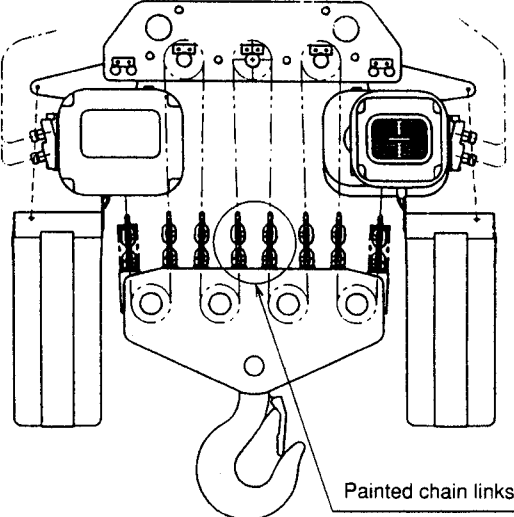
Class	Item	Inspection method	Discard limit/criteria	Remedy																	
Hoist & Trolley	(8) Chain container capacity	Measure the chain length.		If the load chain length exceeds the following length in the table, ALWAYS use the larger optional steel chain container.																	
			<table border="1"> <thead> <tr> <th>WLL (t)</th> <th>7.5</th> <th>10(L)</th> <th>10(S)</th> <th>15</th> <th>20</th> </tr> </thead> <tbody> <tr> <td rowspan="2">Chain length (m)</td> <td>Small container</td> <td>4</td> <td>3</td> <td>6</td> <td>4</td> <td>3</td> </tr> <tr> <td>Large container</td> <td>8</td> <td>6</td> <td>12</td> <td>8</td> <td>6</td> </tr> </tbody> </table>		WLL (t)	7.5	10(L)	10(S)	15	20	Chain length (m)	Small container	4	3	6	4	3	Large container	8	6	12
WLL (t)	7.5	10(L)	10(S)	15	20																
Chain length (m)	Small container	4	3	6	4	3															
	Large container	8	6	12	8	6															
	(9) Load chain position for 2-hoist-equipped-model	Check the position of the painted chain links	Ensure that the painted chain links are located side by side between the two hoists. If they are located 1m or more apart, correct it.	Lower the hook to correct chain alignment until both hoist's limit switch go on.																	
	<p>For 15t</p> 																				
	<p>⚠ WARNING</p> <p>For the case of high capacity models; these models use two separate hoists whose brake performance may differ slightly from one another with respect to breaking distance. After continuous use this difference may increase and the chain could move more to one side than the other.</p>																				

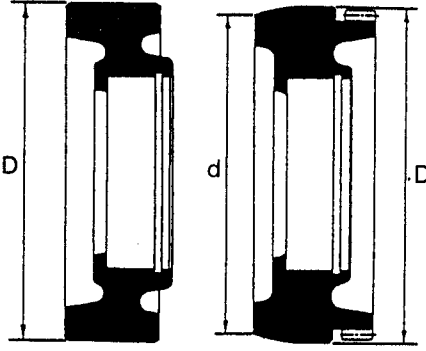
Hoist & Trolley	(4) Wheel abrasion	Measure with slide calipers.	Diameter of tread and flange do not exceed limits on the table shown below.	Adjusting tilted trolley Replace with new wheels if limit is exceeded.														
			 <p>For flat rail For tapered rail</p>															
			<table border="1" style="width: 100%; text-align: center;"> <thead> <tr> <th rowspan="2">WLL (t)</th> <th colspan="2">Tread outside diameter : D</th> <th colspan="2">Tread inside diameter : d</th> </tr> <tr> <th>Standard</th> <th>Limit</th> <th>Standard</th> <th>Limit</th> </tr> </thead> <tbody> <tr> <td>7.5, 10, 15, 20</td> <td>175</td> <td>165</td> <td>166</td> <td>156</td> </tr> </tbody> </table>	WLL (t)	Tread outside diameter : D		Tread inside diameter : d		Standard	Limit	Standard	Limit	7.5, 10, 15, 20	175	165	166	156	Unit : mm
WLL (t)	Tread outside diameter : D		Tread inside diameter : d															
	Standard	Limit	Standard	Limit														
7.5, 10, 15, 20	175	165	166	156														
(8) Side roller wear	Check visually or with slide calipers, as necessary.	Check visually or with slide calipers, as necessary.	Contact part of the side roller is not worn to exceed limit dimensions on the table below.	Replace with new rollers if abrasion exceeds limit.														
	Rotate rollers by hand	Rollers rotate smoothly.		Supply oil to roller shafts occasionally.														
			<table border="1" style="width: 100%; text-align: center;"> <thead> <tr> <th rowspan="2">WLL (kg or t)</th> <th colspan="2">Outside diameter (mm)</th> </tr> <tr> <th>Standard</th> <th>Limit</th> </tr> </thead> <tbody> <tr> <td>7.5t to 20t</td> <td>55</td> <td>54</td> </tr> </tbody> </table>	WLL (kg or t)	Outside diameter (mm)		Standard	Limit	7.5t to 20t	55	54							
WLL (kg or t)	Outside diameter (mm)																	
	Standard	Limit																
7.5t to 20t	55	54																

8. TROUBLESHOOTING

Refer to the "Owner's (Operator's) Manual and Safety Instructions : ERM-9806-MC".



KITO CORP.

3-37-4, Yoyogi, Shibuya-ku,
Tokyo 151-0053, Japan
Tel. : 03-5371-7341
Fax. : 03-5371-7349
Tlx. : 222-2942 KITO J
E-mail : overseas@kito.co.jp
URL [http : //www.kito.co.jp](http://www.kito.co.jp)

KITO CANADA INC.
CHAIN HOISTS

309-3815 1ST AVENUE
BURNABY, BC V5C 3V6
Ph : (604) 291-9955
Fx : (604) 294-8855
E-mail : kitocan@axionet.com