

L5LB Series Lever Chain Hoists

3/4 to 9 metric tonne capacity, tough, smooth-operating hoist



KITO L5 Series Lever Hoists are built with premium grade components for long life in demanding industrial and contracting applications. L5 lever hoists feature double-reduction gearing for reduced size and weight.

FEATURES

- At rated capacity, load-bearing parts are only stressed to 25% of their limit
- Patented induction hardening process on load bearing parts increases strength and rigidity of the frame
- Abrasion and corrosion resistant, nickel plated load chain made from heat-treated alloy steel for high, uniform strength
- Articulating top hook allows you to properly centre the load
- Forged carbon steel hook design will not fracture under excessive load
- Protective guard around the chain pin for enhanced safety
- Safety tip hook latch design is thicker for increased durability, and notched to securely engage with the hook tip
- Reliable weston-style mechanical brake design holds the load securely
- Five-start thread on brake ensures a level braking surface to ease load break-out
- Double-reduction gearing requires minimum manual power for operation
- Spring-loaded freewheel for quick and easy hook positioning
- Open load sheave allows easy inspection and cleaning without dismantling the unit
- 360° handle rotation for a sure grip from any operating position
- Compact design for lightweight portability
- High-impact steel housing has similar weight to aluminum due to compact design
- Sealed gears and brake are protected against damage from dust and water
- Cap nuts protect exposed bolts from damage
- Available in capacities of .75, 1.5, 2.5, 3, 6 and 9 metric tonnes
- Test Load: 125% of rated capacity

STANDARDS

- ASME B30.21 Safety Standard
- ASME HST-3 Performance Standard
- Grade 100, Nickel Plated Chain

OPTIONS

- Slip Clutch protects hoist in the event of an excessive overload
- Black Chain for heavy welding applications
- Custom lift lengths to suit your requirements

L5LB Steel Body - Lever Hoists

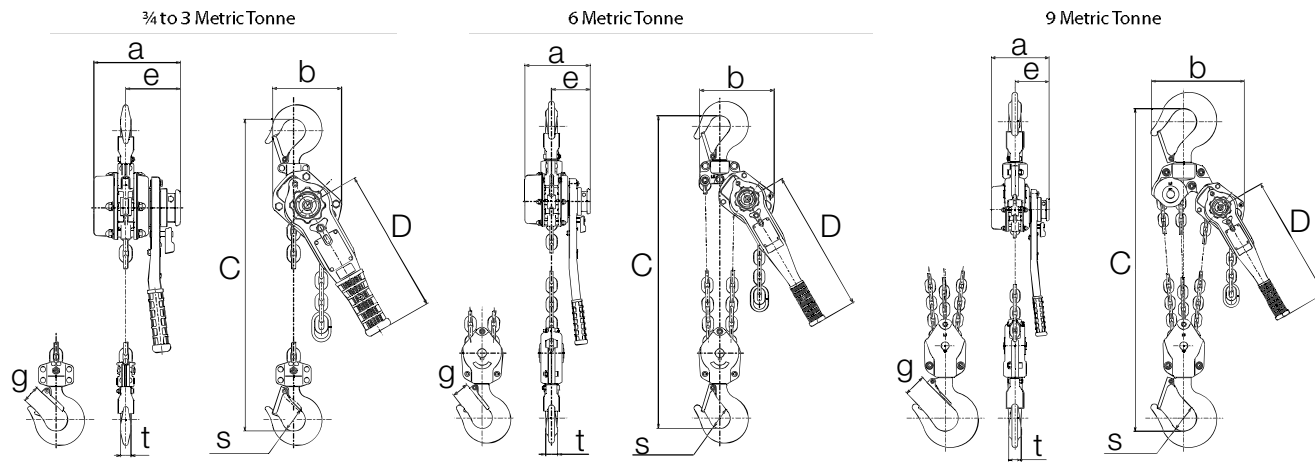

DIMENSIONS (mm)

Capacity (tonne)	Model	C	D	a	b	e	g	s	t
¾	L5LB008	280	245	144	119	97	23.5	35.5	14
1½	L5LB015	335	265	159	126	100	32	42.5	19
2½	L5LB025	375	265	173	150	102	36.5	47	21
3	L5LB030	395	415	190	159	112	39	50	24.5
6	L5LB060	540	415	190	217	112	50	60	34
9	L5LB090	680	415	190	304	112	72.5	85	41.5

SPECIFICATIONS

Capacity (tonne)	Model	Standard Lift (ft)	Hand Pull to Lift Full Load (kg)	Headroom (in)	Handle Length (in)	Load Chain Code	Load Chain Falls	Ship Weight (lbs)	Weight per Additional 5 ft of Lift (lbs)
¾	L5LB008	5	27	11	9.75	KLB5056	1	13	3
1½	L5LB015	5	32	13.25	10.5	KLB5071	1	18	4
2½	L5LB025	5	37	14.75	10.5	KLB5088	1	26	6
3	L5LB030	5	35	15.5	16.5	KLB5100	1	35	8
6	L5LB060	5	36	21.25	16.5	KLB5100	2	59	16
9	L5LB090	5	39	26.75	16.5	KLB5100	3	92	24

L5LB WITH OPTIONAL SLIP CLUTCH

Slip Clutch hoists make for safer worksites. This internal mechanism protects the hoist from damage in the event of an excessive overload, with no increase in size.



Black freewheel knob easily distinguishes the slip clutch unit from standard lever hoists.