

LX Series Lever Chain Hoists

1/4 and 1/2 metric tonne capacity, pocket-sized lever hoist



KITO LX Series Lever Hoists are suitable for work in tight quarters or elevated locations where fastening, fixing or positioning of light loads is required. LX lever hoists feature a low hand pull force for highly reliable lifting.

FEATURES

- At rated capacity, load-bearing parts are only stressed to 25% of their limit
- Abrasion and corrosion resistant, plated load chain
- Forged carbon steel hook design will not fracture under excessive load
- 360° handle rotation for a sure grip from any operating position
- Articulating top hook allows you to properly centre the load
- Safety tip hook latch design is thicker for increased durability, and notched to securely engage the latch with the hook tip
- Aluminum housing for reduced weight
- Sealed gears and brake are protected against damage from dust and water
- Free chain adjusting mechanism for quick and easy hook positioning
- Test Load: 125% of rated capacity

STANDARDS

- ASME B30.21 Safety Standard
- ASME HST-3 Performance Standard
- Grade 100 Chain

OPTIONS

- Carrying case that can be attached to your belt for added convenience (LX003)
- Custom lift lengths to suit your needs

DIMENSIONS (mm)

Capacity (tonne)	Model	C	D	a	b	e	g	s	t
¼	LX003	205	150	85.5	73.5	60	21	32	11
½	LX005	246	180	93	93	63	24.5	35.5	12

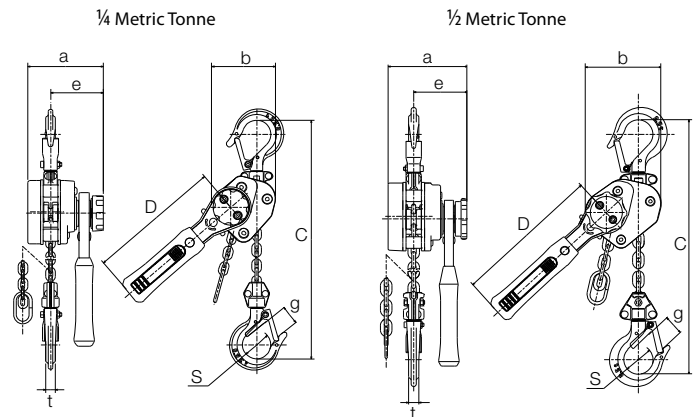

SPECIFICATIONS

Capacity (tonne)	Model	Standard Lift (ft)	Hand Pull to Lift Full Load (kg)	Headroom (in)	Handle Length (in)	Load Chain Code	Load Chain Falls	Ship Weight (lbs)	Weight per Additional 5 ft of Lift (lbs)
¼	LX003	3	20	8	6	KLX032	1	4	2
½	LX005	4	31	9.75	7	KLX043	1	6	2