

**CSA**

MR SERIES MOTORIZED TROLLEY MODEL MR 1 7.5 TO 20t

PARTS LIST

IMPORTANT

When ordering replacement parts, please specify the following points :

1. Voltage
2. Trolley capacity
3. Model number in name plate
4. Correct part names and numbers
5. Lineal length of push button cord or power supply cable

NOTE

There are two kinds of track wheel for 7.5t trolley. standard wheel is to be used for tapered flange beam. If your beam is flat flange beam, inform before placing order.

CONTENTS

A. MOTOR AND GEARING PARTS	1
B. HOUSING PARTS	3
C. CONTROL STATION AND CABLE PARTS	5
D. PUSH BUTTON CONTROL STATION PARTS	9
E. OPTIONAL PARTS FOR 7.5t	11

A MOTOR AND GEARING PARTS

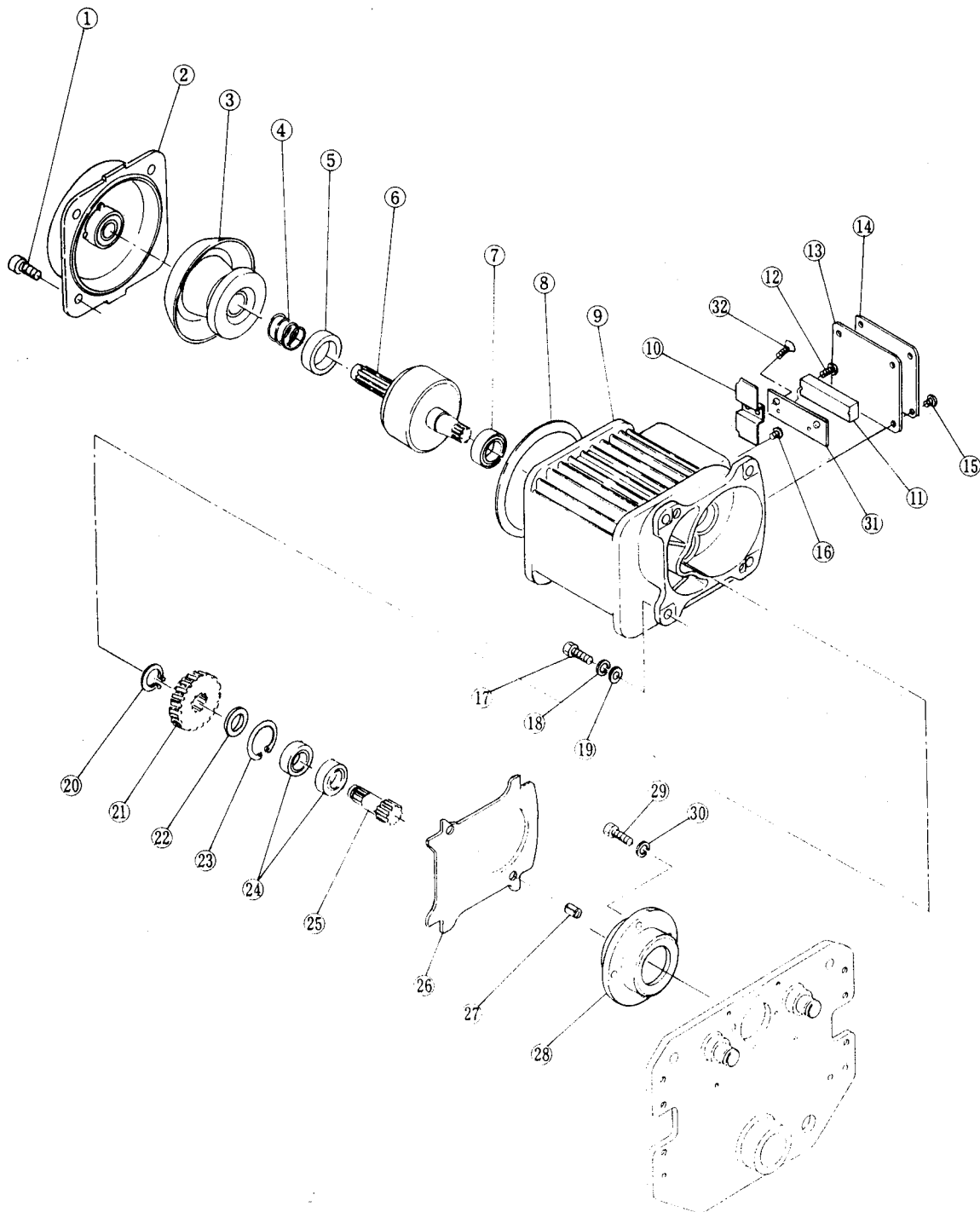
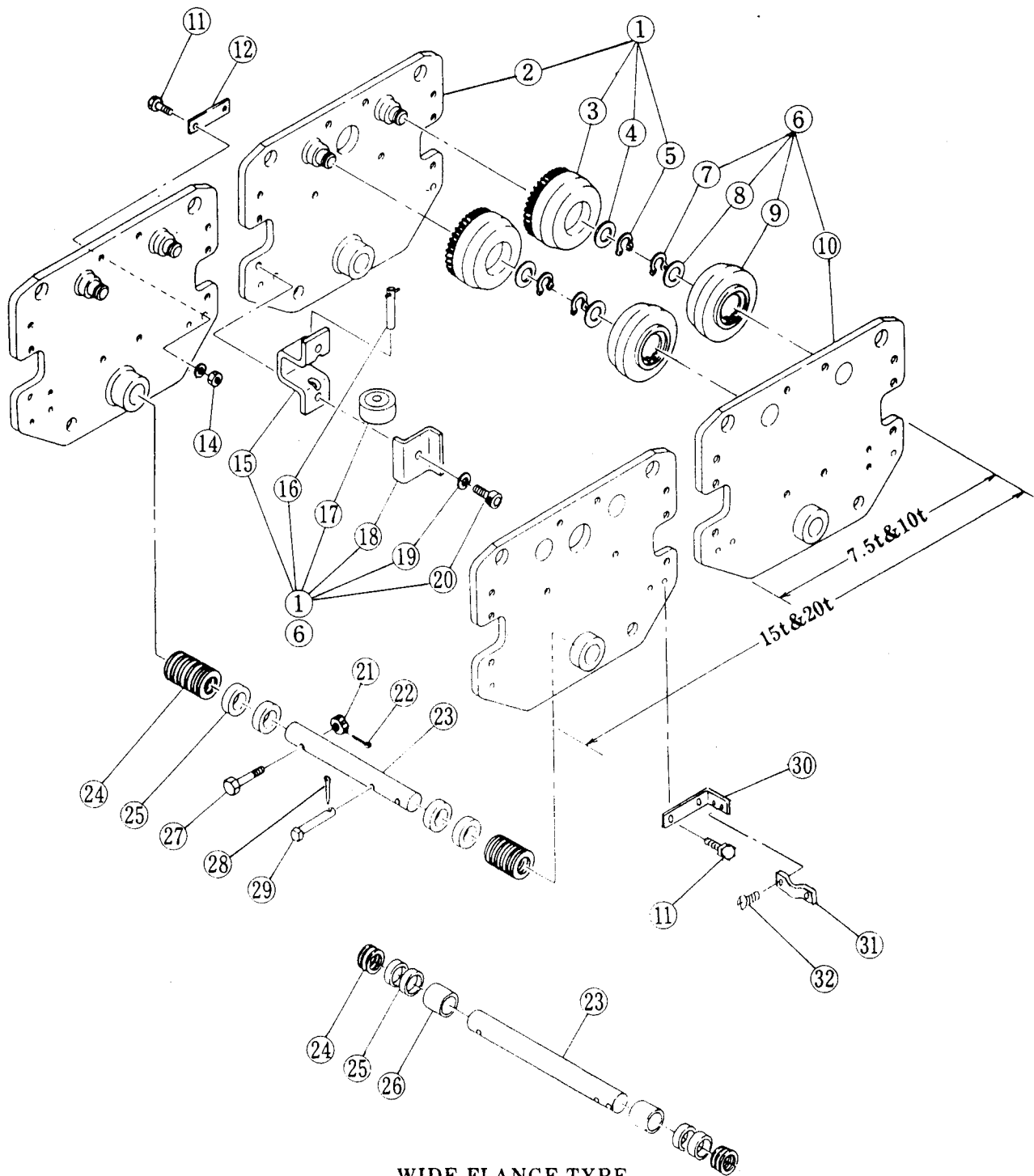

Fig No.	Part No.	Part name	Single speed									
			No. per Trolley					Capacity				
			7.5t	10t(L)	10t(S)	15t	20t	7.5t	10t(L)	10t(S)	15t	20t
Motor and gearing parts												
1	304	Socket bolt		4			8					
2	1301	Motor cover assembly		1			2					
3	5261	Brake drum assembly		1			2					
4	264	Brake spring		1			2					
5	265	Bumper		1			2					
6	5291	Motor shaft with rotor		1			2					
7	253	Ball bearing		1			2					
8	281	Guard		1			2					
9	5321	Motor frame with stature		1			2					
10	326	Coil cover		1			2					
11	851	Terminal plate 6P		1			2					
12	332	Machine screw with spring washer		2			4					
13	325	Terminal cover packing		1			2					
14	324	Terminal cover		1			2					
15	331	Machine screw with spring washer		4			8					
16	334	Machine screw with spring washer		1			2					
17	250	Bolt		4			8					
18	251	Spring washer		4			8					
19	252	Washer		4			8					
20	246	Snap ring		1			2					
21	241	Gear #2 (S)		1			2					
22	244	Spacer		1			2					
23	258	Snap ring		1			2					
24	245	Ball bearing		2			4					
25	242	Gear #3		1			2					
26	248	Gear box packing		1			2					
27	249	Set pin		2			4					
28	257	Bearing holder		1			2					
29	259	Sochet bolt		4			8					
30	260	Spring lock washer		4			8					
31	855	Terminal cover		1			2					
32	857	Tapping flat head machine screw		2			4					

B HOUSING PARTS



WIDE FLANGE TYPE
AS OPTION

Fig No.	Part No.	Part name	Single speed											
			No. per Trolley					Capacity						
			7.5t	10t(L)	10t(S)	15t	20t	7.5t	10t(L)	10t(S)	15t	20t		
Housing parts														
1	3201	Side plate G complete set			1					2				
2	5201	Side plate G assembly			1					2				
3	1231	Track wheel G assembly			2					4				F
	1237	Track wheel GF assembly			2					4				Z
	233	Ball bearing			2					4				
	234	Snap ring			2					4				
	235	Washer			2					4				
4	236	Snap ring			2					4				
5	236	Snap ring			2					4				
15	214	Side roller holder			4					8				
16	215	Roller pin			4					8				
17	2211	Side roller assembly			4					8				
18	218	Stopper plate			4					8				
19	220	Spring lock washer			8					16				
20	219	bolt			8					16				
6	3202	Side plate S complete set			1					2				
10	5202	Side plate S assembly			1					2				
9	1232	Track wheel S assembly			2					4				F
	1238	Track wheel SF assembly			2					4				Z
	233	Ball bearing			2					4				
	234	Snap ring			2					4				
7	236	Snap ring			2					4				
8	235	Washer			2					4				
11	226	Bolt			—					4				
12	224	Connection plate			—					4				
14	227	Nut			—					4				
21	104	Slotted Nut												
22	105	Split pin												
23	101	Suspension shaft (220)												
		Suspension shaft (300)												W
24	109	spacer								8				
25	102	Thick spacer B												F
														W
26	108	Fixing spacer								2				W
27	103	Bolt								1				
28	107	Split pin								1				
29	106	Shaft stopper pin								1				
30	225	Connection plate S			—					1				
31	816	Cord chain stopper			—					1				
32	817	Machine screw with spring washer			—					2				

NOTE:<F> indicates Tapered flange wheel.

:<Z> indicates Flat flange wheel.

:<W> indicates the quantity for wide flange type.

C CONTROL STATION AND CABLE PARTS

Emergency stop type 7.5t, 10t(L)

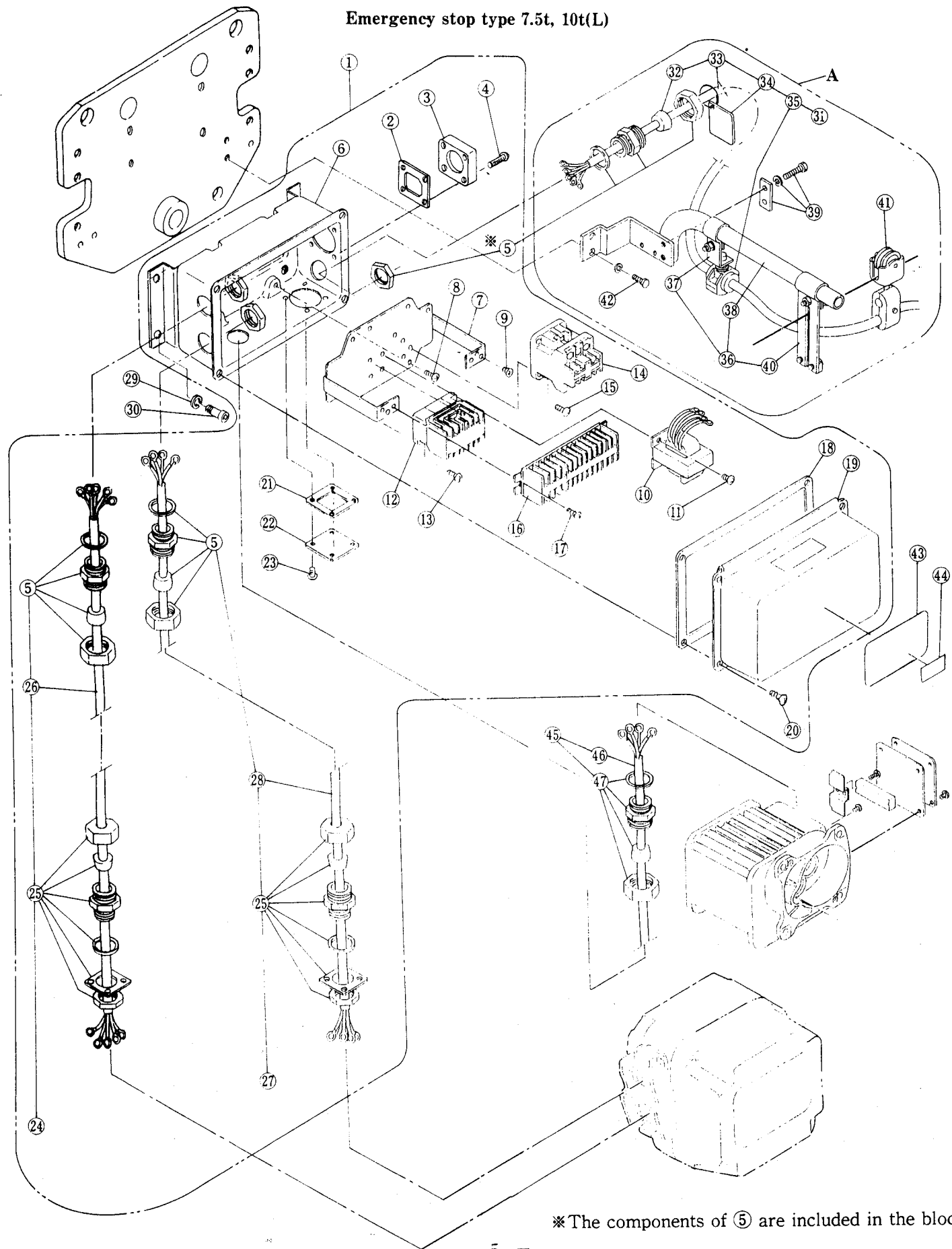

※The components of ⑤ are included in the block, ①.

Fig No.	Part No.	Part name	Single speed		
			No. per Hoist	Capacity	
				7.5t	10t(L)

Control station and cable parts
7.5t,10t(L)

1	1401	Switch box complete set	1		
2	818	Socket holder P	1		
3	361	Cord holder support packing	1		
4	820	Machine screw with spring washer	4		
5	344	Cord holder nut	1		
	343	Cord packing	1		
	342	Cord holder B	1		
	341	Cord holder A	1		
6	2401	Switch box assembly	1		
7	5445	Plate assembly	1		
8	454	Machine screw with spring washer	4		
9	451	Machine screw with spring washer	4		
10	881	Transformer	1		
11	455	Machine screw with spring washer	2		
12	871	Electromagnetic contactor	1		
13	453	Machine screw with spring washer	2		
14	873	Electromagnetic contactor	1		
15	457	Machine screw with spring washer	4		
16	853	Terminal plate 16 P	1		
17	452	Machine screw with spring washer	2		
18	421	Switch box packing	1		
19	411	Switch box lid	1		
20	422	Machine screw with spring washer	4		
21	343	Cord holder support packing	1		
22	347	Cord cover	1		
23	348	Machine screw with spring washer	4		
24	1761	Cable 4C complete set	1		
25	344	Cord holder nut	1		
	350	Cord holder plate	1		
	352	Cord holder plate packing	1		
	343	Cord packing	1		
	342	Cord holder B	1		
	351	Cord holder packing	1		
26	761	Power supply cable 4C	1		
27	1751	Cable 4C complete set	1		
28	751	Cable 4C	1		
29	407	Spring lock washer	4		
30	406	Socket bolt	4		
31	1771	Power supply cable assembly	1		
32	351	Cord holder packing	1		
33	771	Power supply cable 4C	1		
34	775	Tag F	1		
35	1724	Cable support 19 assembly	1		
36	1491	Cable support bar complete set	1		
37	492	Cable support arm	1		
	497	Bolt	1		
	498	Spring lock washer	1		
	499	Nut	1		
38	491	Cable support bar	1		
39	501	Support bar holder	1		
	505	Spring lock washer	2		
	506	Bolt	2		
40	1493	Wire guide assembly	1		
41	1641	Cable hanger 15 assembly	1		
42	482	Socket bolt	2		
43	700	Name plate B	1		
44	721	Name plate C	1		
45	1791	Trolley cable 4C assembly	1		
46	791	Trolley cable 4C	1		
47	343	Cord packing	1		
	342	Cord holder B	1		
	351	Cord holder packing	1		
	341	Cord holder A	1		

Emergency stop type 10t(S), 15t, 20t

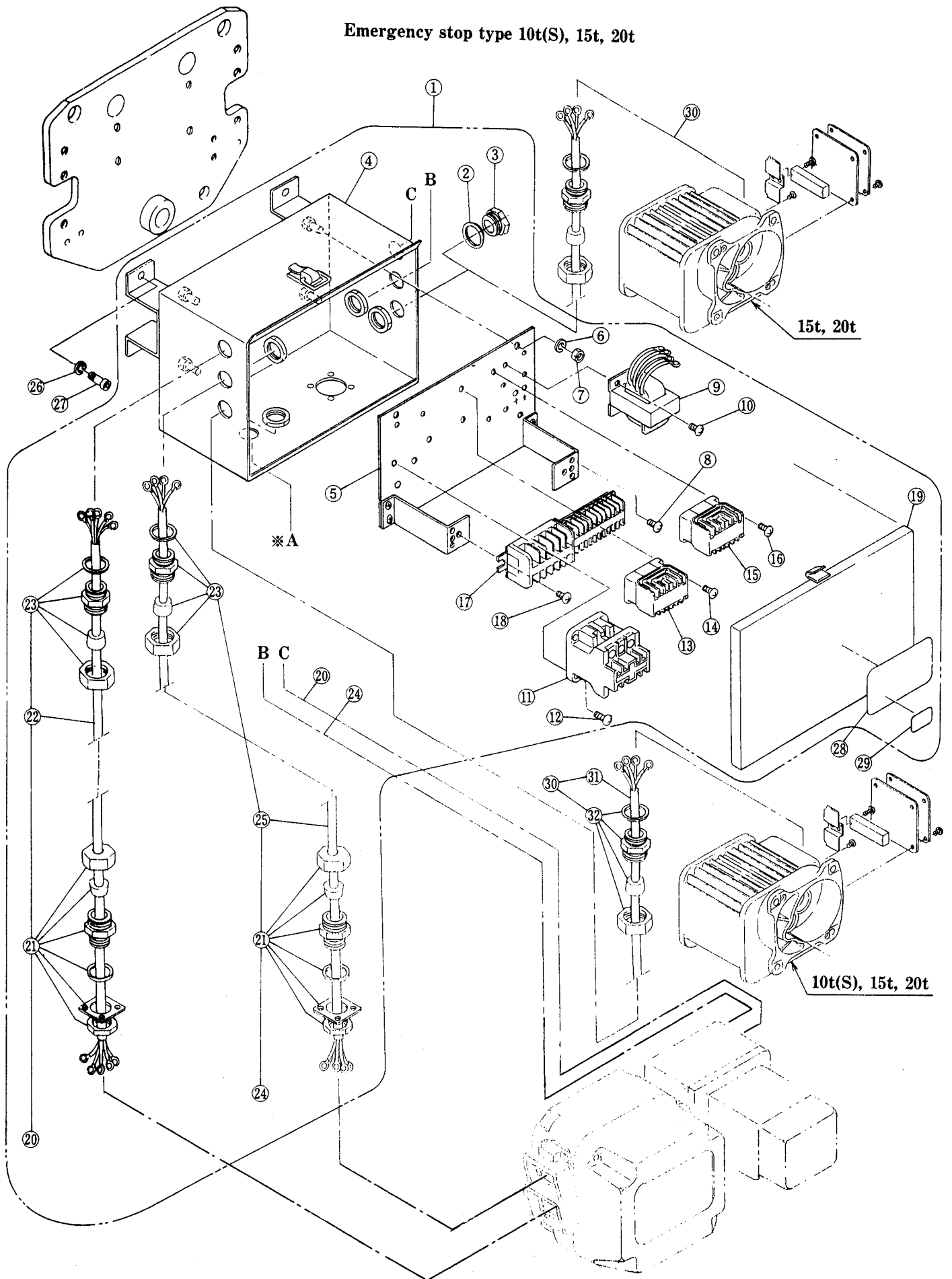

*A above is identical to A in the page 5 for 7.5t, 10t(L).

Fig No.	Part No.	Part name	Single speed					
			No. per Hoist			Capacity		
			10t(S)	15t	20t	10t(S)	15t	20t

Control station and cable parts

10t(S),15t,20t

1	1401	Switch box complete set		1				
2	343	Cord packing		1				
3	345	Holder cover		1				
4	2401	Switch box assembly		1				
5	5445	Plate assembly		1				
6	463	Spring lock washer		4				
7	462	Nut		4				
8	451	Machine screw with spring washer		6				
9	881	Transformer		1				
10	455	Machine screw with spring washer		4				
11	873	Electromagnetic contactor		1				
12	457	Machine screw with spring washer		2				
13	871	Electromagnetic contactor		1				
14	453	Machine screw with spring washer		2				
15	874	Electromagnetic contactor		1				
16	459	Machine screw with spring washer		2				
17	853	Terminal plate 18 p		1				
18	452	Machine screw with spring washer		2				
19	411	Switch box lid		1				
20	1761	Cable 3C complete set		1				
21	344	Cord holder nut		1				
	350	Cord holder plate		1				
	352	Cord holder plate packing		1				
	343	Cord packing		1				
	342	Cord holder B		1				
	351	Cord holder packing		1				
	341	Cord holder A		1				
22	761	Power supply cable 3C		1				
23	344	Cord holder nut		1				
	343	Cord packing		1				
	342	Cord holder B		1				
	351	Cord holder packing		1				
	341	Cord holder A		1				
24	1751	Cable 4C complete set		1				
25	751	Cable 4C		1				
26	407	Spring lock washer		4				
27	406	Socket bolt		4				
28	700	Name plate B		1				
29	721	Name plate C		1				
30	1791	Trolley cable 4C assembly	1		2			
31	791	Trolley cable 4C	1		2			
32	343	Cord packing	1		2			
	342	Cord holder B	1		2			
	351	Cord holder packing	1		2			
	341	Cord holder A	1		2			

D PUSH BUTTON CONTROL STATION PARTS

7.5t, 10t(L)

10t(S), 15t, 20t

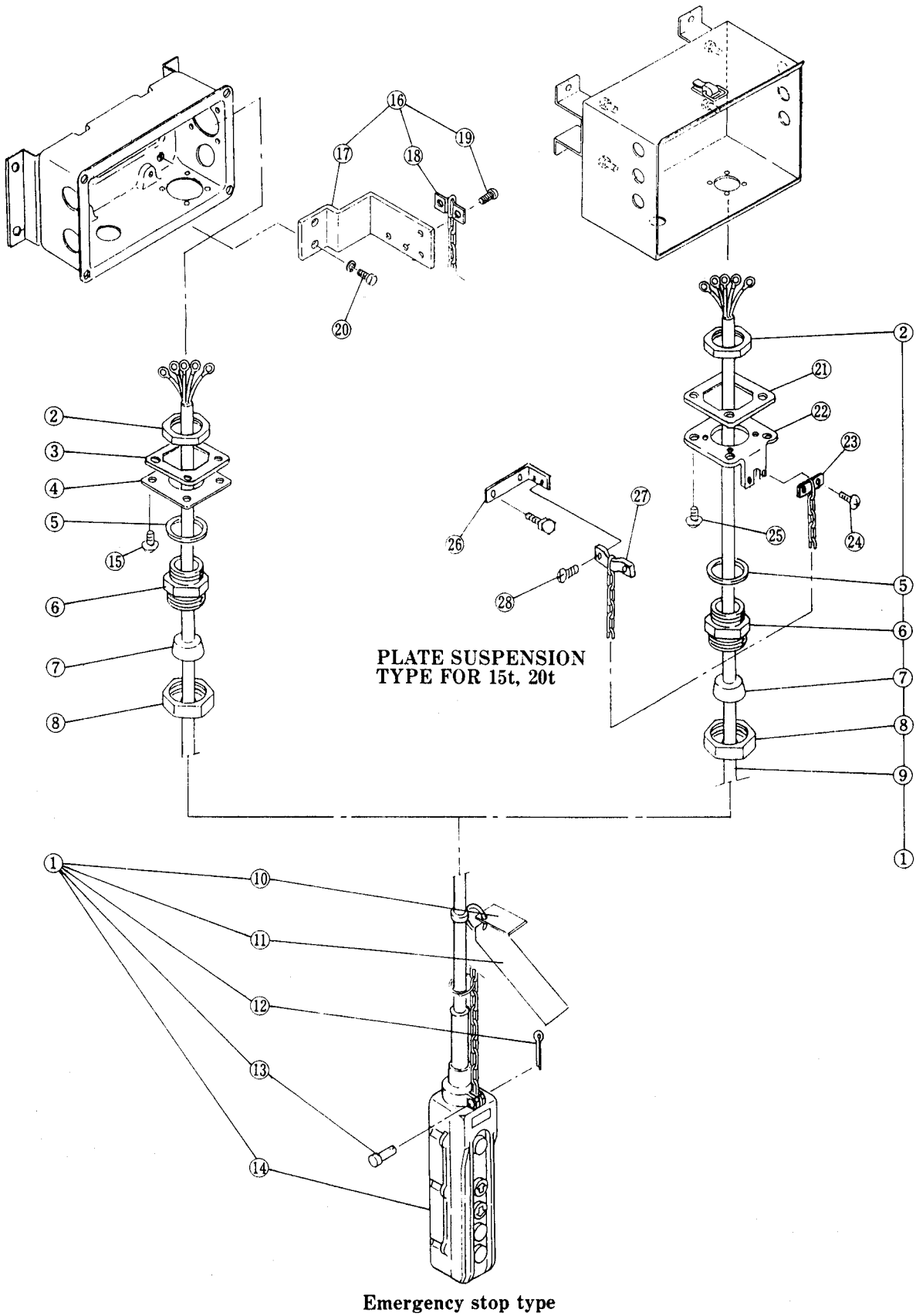

Fig No.	Part No.	Part name	Single speed									
			No. per Trolley					Capacity				
			7.5t	10t(L)	10t(S)	15t	20t	7.5t	10t(L)	10t(S)	15t	20t

Push button control station parts
7.5t,10t(L)

1	1781	Push button cord 7C assembly	1											
2	344	Cord holder nut	1											
3	818	Cord holder plate packing	1											
4	349	Plate D	1											
5	343	Cord packing	1											
6	342	Cord holder B	1											
7	351	Cord holder packing	1											
8	341	Cord holder A	1											
9	781	Push button cord 8C	1											
10	776	Tag S	1											
11	781	Warning tag K	1											
12	788	Cord support pin B	1											
13	789	Split pin	1											
14	1801	5 Push button switch MSS assembly	1											
15	820	Machine screw with spring washer	4											
16	—	Bar holder assembly	1											
17	481	Bar holder	1											
18	816	Cord chain stopper	1											
19	817	Machine screw with spring washer	2											
20	482	Socket bolt	2											

10t(S),15t,20t

1	1781	Push button cord 6C assembly				1								
2	344	Cord holder nut				1								
5	343	Cord packing				1								
6	342	Cord holder B				1								
7	351	Cord holder packing				1								
8	341	Cord holder A				1								
9	781	Push button cord 8C				1								
10	776	Tag S				1								
11	783	Warning tag K				1								
12	788	Cord support pin B				1								
13	789	Split pin				1								
14	1801	5 Push button switch MSS assembly				1								
21	818	Terminal cover packing				1								
22	815	Socket holder				1								
23	817	Machine screw with spring washer				2								
24	816	Cord chain stopper				1								
25	820	Machine screw with spring washer				4								
26	225	Connection plate S				1								
27	535	Cord support wire stopper				1								
28	536	Machine screw with spring washer				2								

E OPTIONAL PARTS FOR 7.5t

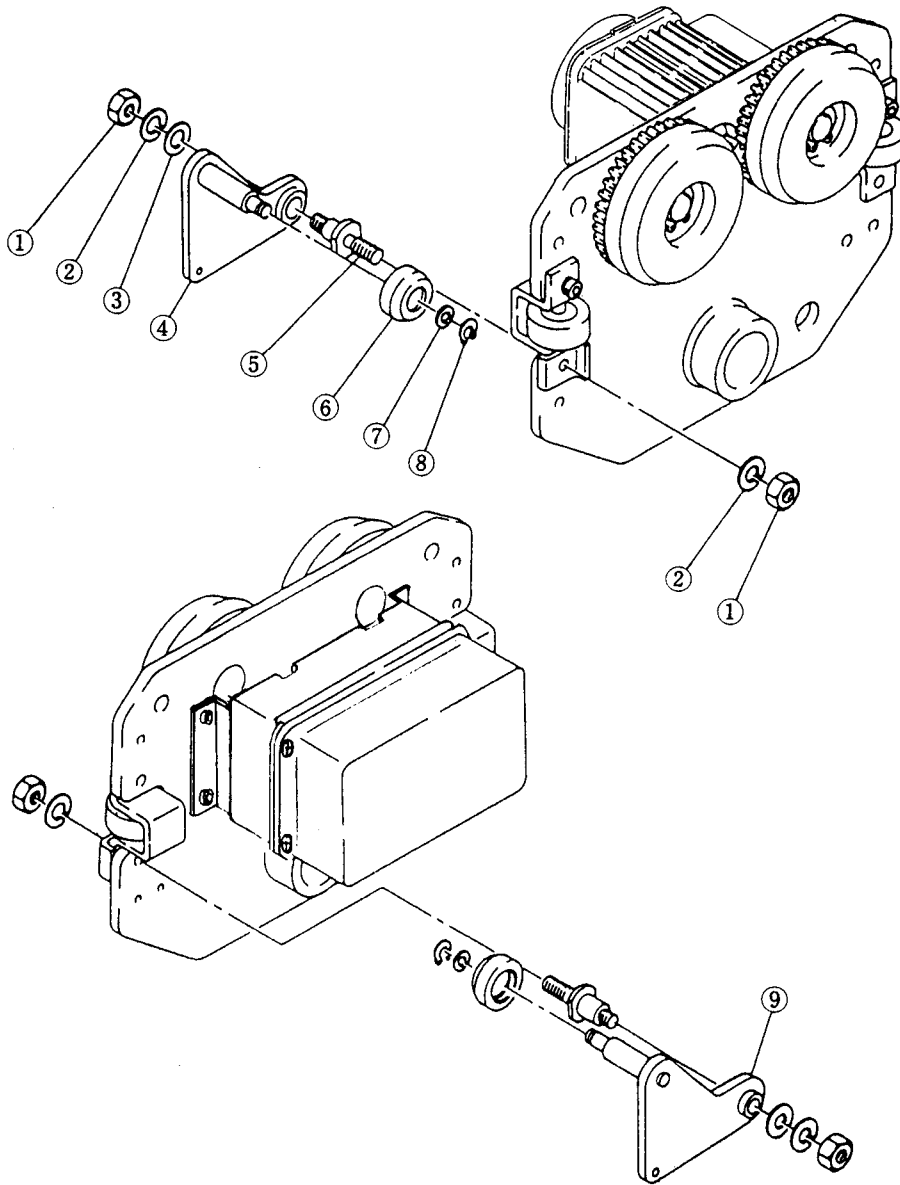

Fig No.	Part No.	Part name	Single speed	
			No. per Trolley	Capacity
			7.5t	7.5t

Optional parts for 7.5t

1	411	Nut	4	
2	413	Spring washer	4	
3	412	Washer	2	
4	5401	Hunger plate A assembly	1	
5	408	Bolt	2	
6	1405	Hunger wheel assembly	2	
7	407	Wheel washer	2	
8	414	Snap ring	2	
9	5402	Hunger plate B assembly	1	



KITO CORP.

3-37-4, Yoyogi, Shibuya-ku,

Tokyo 151-0053, Japan

Tel. : 03-5371-7341

Fax. : 03-5371-7349

Tlx. : 222-2942 KITO J

E-mail : kitoexpt@mtg.biglobe.ne.jp

URL <http://www.kito.co.jp>