

RANGER™

MOBILE ANCHOR

ARREST FALLS.
ANYWHERE.



GORBEL®
A CLASS ABOVE

RANGER™

MOBILE ANCHOR

VERSATILE FALL ARREST ANCHOR. ANYWHERE.

The versatile Ranger™ Mobile Anchor from Gorbel® provides the necessary anchorage point right where you need it, indoors or out. Perfect for use when maintaining aircraft, railroad cars, industrial equipment or heavy machinery. This new addition to the Tether Track™ line can be easily moved into position and erected. The Ranger's sleek, balanced design allows for easy towing and transport around the job site.

Adjustable height 2-in. ball coupler attaches to trucks, or related towing devices. Integral fork pockets allow for smooth loading and unloading of Ranger during transport or for general movement via fork lift. All components are easily accessible at ground level for easy adjustment. Mast extends in a direct path for use in tight environments.

- Easy to position with mast in folded position or fully deployed
- Fully extends to 18, 20, or 22 ft. height to address a wide range of jobs
- Allows single user to move freely within a 30 degree work angle in all directions
- Rugged steel construction and components for superior strength
- Resilient finish to withstand harsh outdoor and indoor environments
- Hinged tow bar conveniently folds out of way

■ **STOWAWAY DOLLY** – Permits a single user to maneuver the Ranger into position even with the mast fully deployed. Conveniently attaches to bottom of unit when not in use.

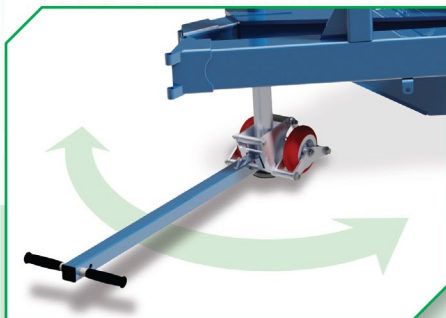

■ **LARGE/LOCKABLE STORAGE BOX** – Allows easy access to controls, permits storage of harnesses, self-retracting lanyards, and taglines.

■ **PIN ADJUSTMENT FOR VARIOUS HEIGHTS (18, 20, 22 FT)**

■ **AUTOMATIC LOCKING SPRING PIN INDICATES WHEN MAST IS FULLY DEPLOYED**

■ **AUTOMATIC OVER CENTER LOCKING HINGE PROVIDES SAFETY REDUNDANCY**

■ **ACCESSIBLE BUBBLE LEVEL AIDS IN LEVELING**

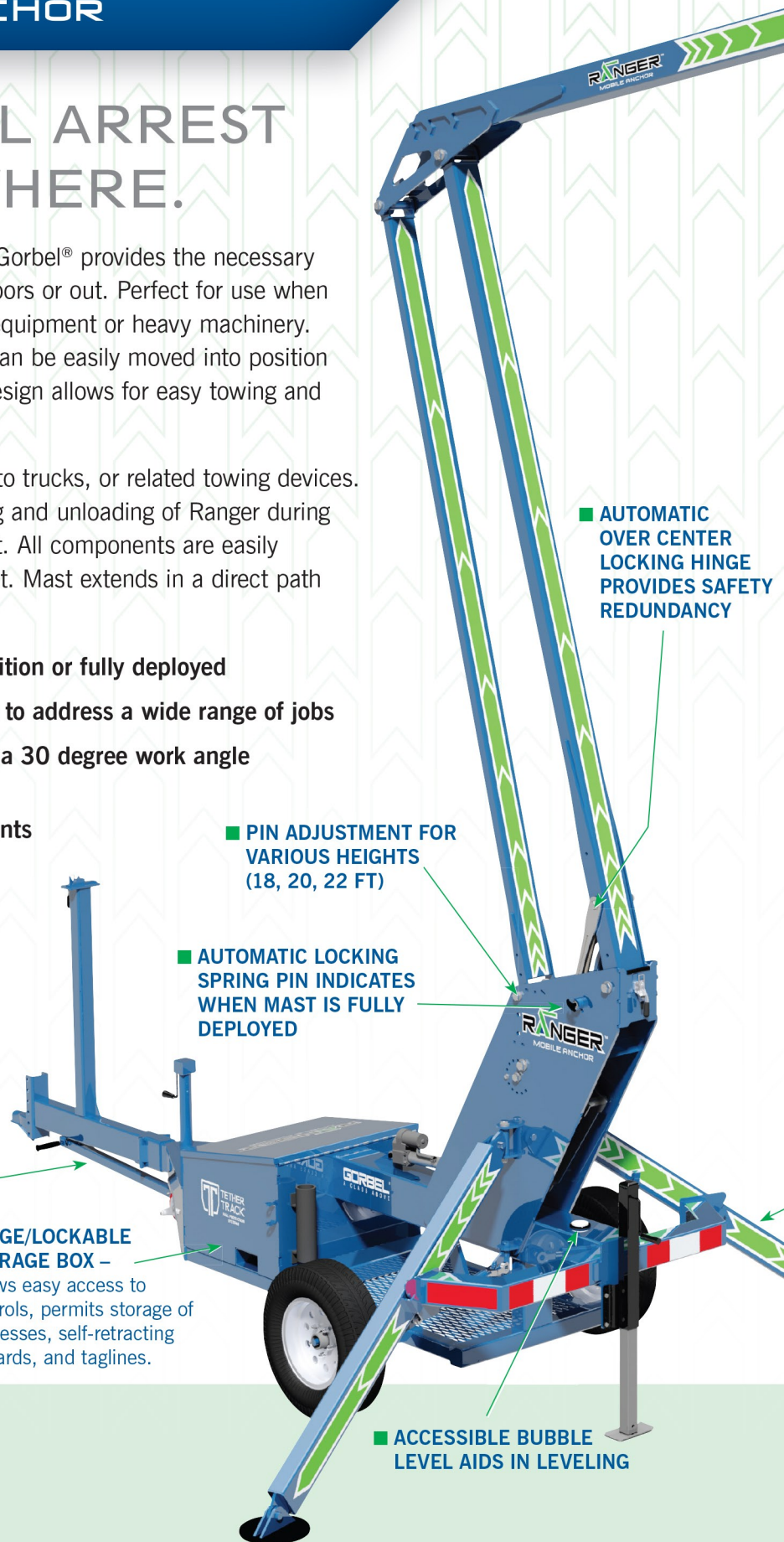

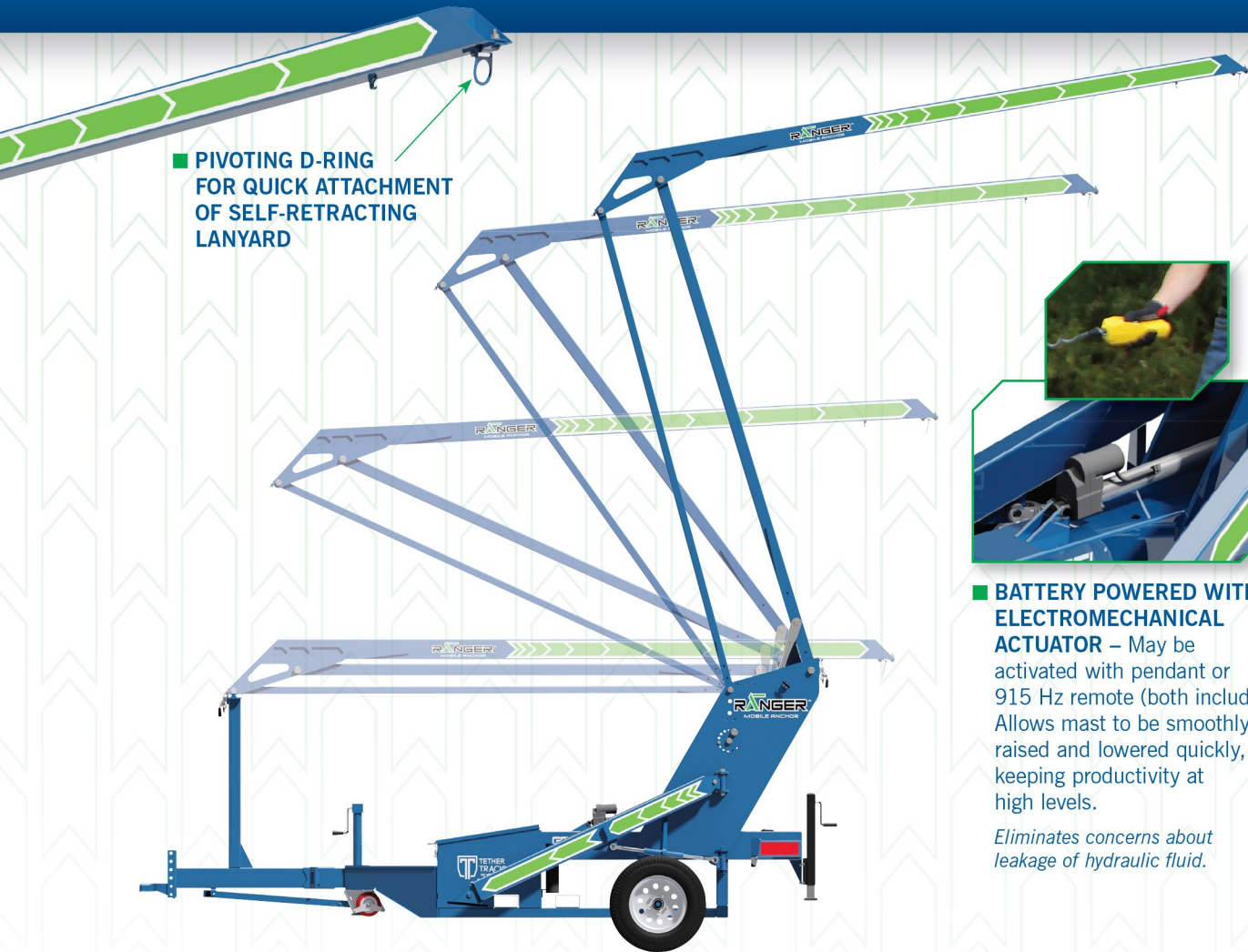

■ PIVOTING D-RING FOR QUICK ATTACHMENT OF SELF-RETRACTING LANYARD



■ BATTERY POWERED WITH ELECTROMECHANICAL ACTUATOR – May be activated with pendant or 915 Hz remote (both included). Allows mast to be smoothly raised and lowered quickly, keeping productivity at high levels.

Eliminates concerns about leakage of hydraulic fluid.

MAX. HEIGHT 22 FT.

The Ranger permits workers to maneuver and set-up in areas where periodic maintenance and related activities must be performed on large equipment. Additionally, the Ranger is the perfect solution when inspections must be performed on outdoor generators, holding tanks and other large

pieces of equipment that have no reliable options for tie-off. Used in conjunction with a full body harness and self-retracting lifeline, the Ranger Mobile Anchor provides a complete fall arrest system “on the go.”

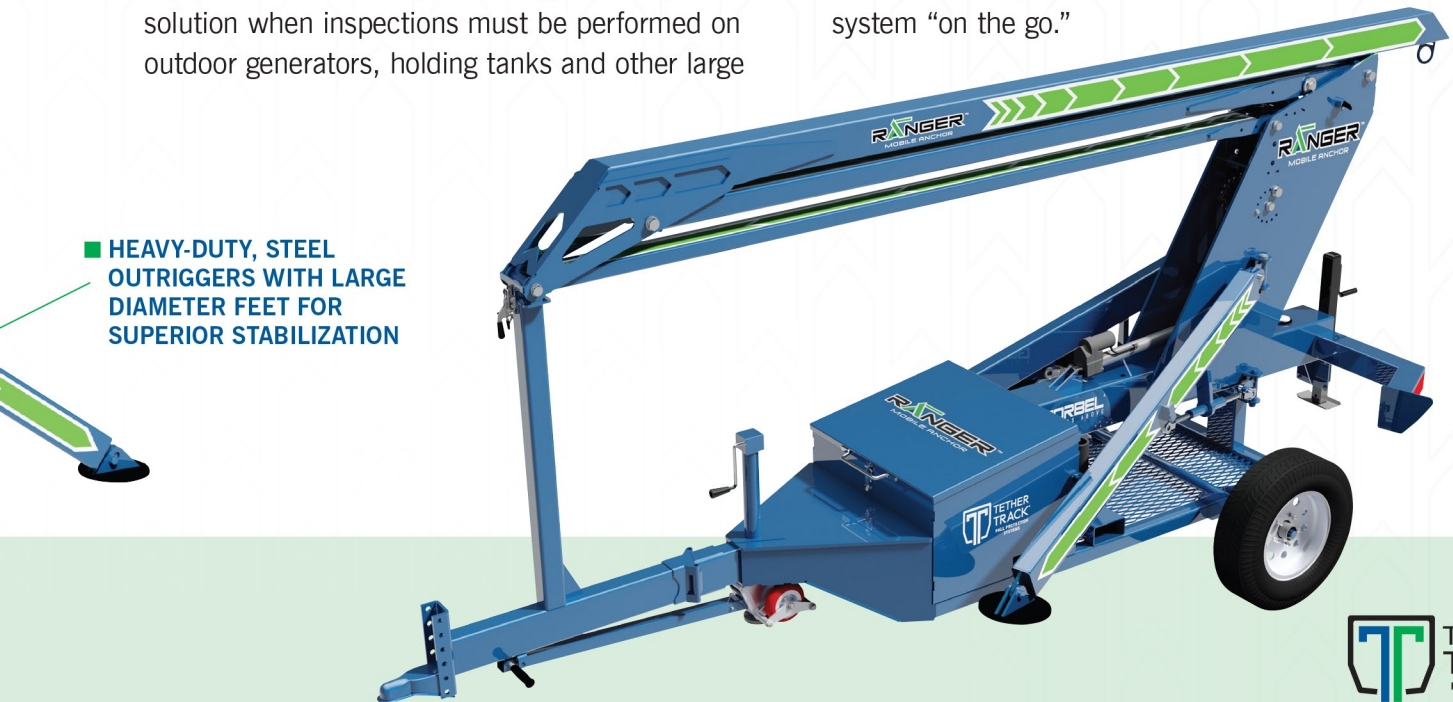

■ HEAVY-DUTY, STEEL OUTRIGGERS WITH LARGE DIAMETER FEET FOR SUPERIOR STABILIZATION

The Ranger™ Mobile Anchor meets OSHA fall protection codes and ANSI Z359.6 design requirements for fall arrest systems.

GENERAL:	
Reach at 18-ft.	8'-6"
Reach at 20-ft.	8'
Reach at 22-ft.	6'-10"
Total Weight:	2,685 lbs.
WHEN IN USE:	
Length when Set-up (excluding reach)	11'
Width with Outriggers Extended	11'
Actuating Method	12V Linear Actuator
Controls	Wired Pendent or 915 Hz Wireless
Power Source	12V Battery
Charging System	110V, 10 Amp Quick Charger
Outrigger System	Manual Ratcheting
Maximum Capacity	310 lbs.
Total Workers Allowed	1
WHEN TOWING:	
Width when Towed	5'-6"
Height when Towed	6'-6"
Length when Towed	15'-3"
Maximum Towing Speed	25 mph

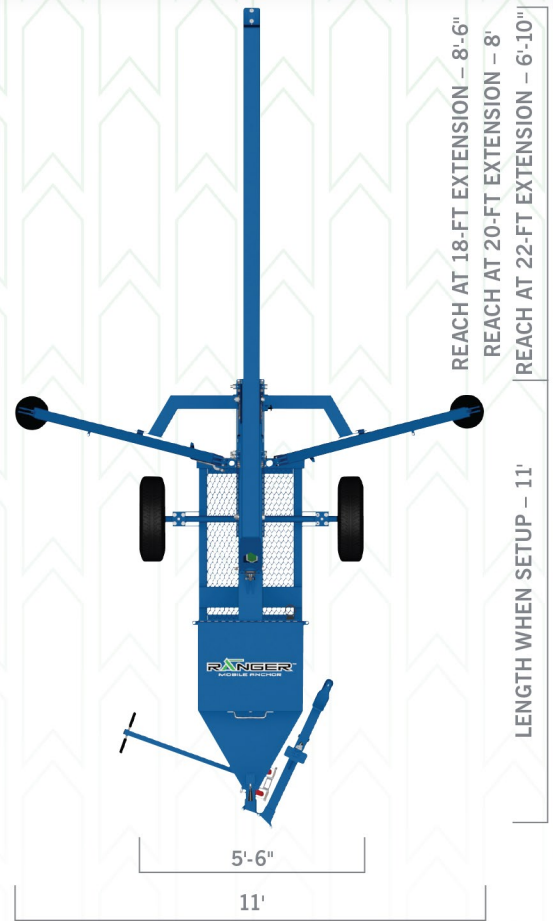



SEE THE RANGER IN ACTION!
Scan with your smartphone's QR reader to watch video.



GORBEL[®]
A C L A S S A B O V E



www.gorbel.com

GORBEL
600 Fishers Run
PO Box 593
Fishers, NY 14453 USA

T 800.821.0086
T 585.924.6262
F 585.924.6273
E info@gorbel.com