

RHN Series Electric Wire Rope Hoists

Easy Maintenance Control Panel

IP55 protection with modern controls. Components mounted on DIN rail. Equipped with main line contactor.

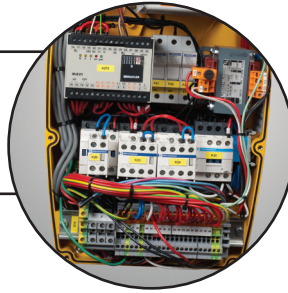

Adjustable Geared Limit Switch

Operation of switch set for upper and lower block position and emergency limit.

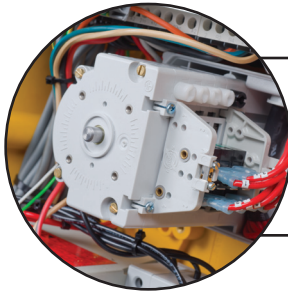

Motor Management

Equipped with overload cut-off and count hour meter.

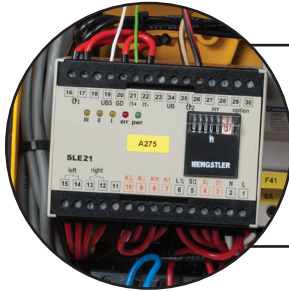

Helical Gearing

Provides maintenance free, smooth and quiet operation.

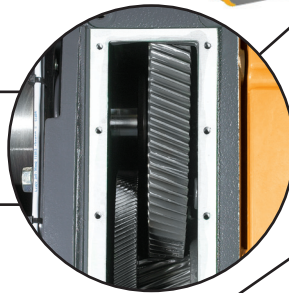

Heavy Duty Cylindrical Motor

Fan cooled (TEFC) with class F insulation and a ribbed frame for maximum cooling and durability. High protection class IP55 and positive temperature control (PTC) thermal sensors.

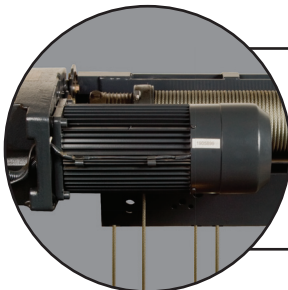

Heavy Duty Electromagnetic Brake

Totally enclosed and fan cooled to ensure long life. Easy to inspect. 1 million cycles.

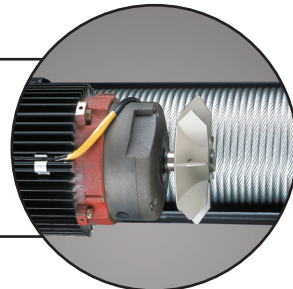

Load Limiter

Reduces the potential for making hazardous, over-capacity lifts. Overloading the hoist electrically activates the load limiter sensor, making hoist lifting inoperable.



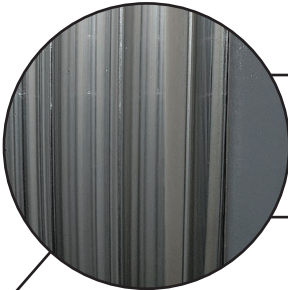
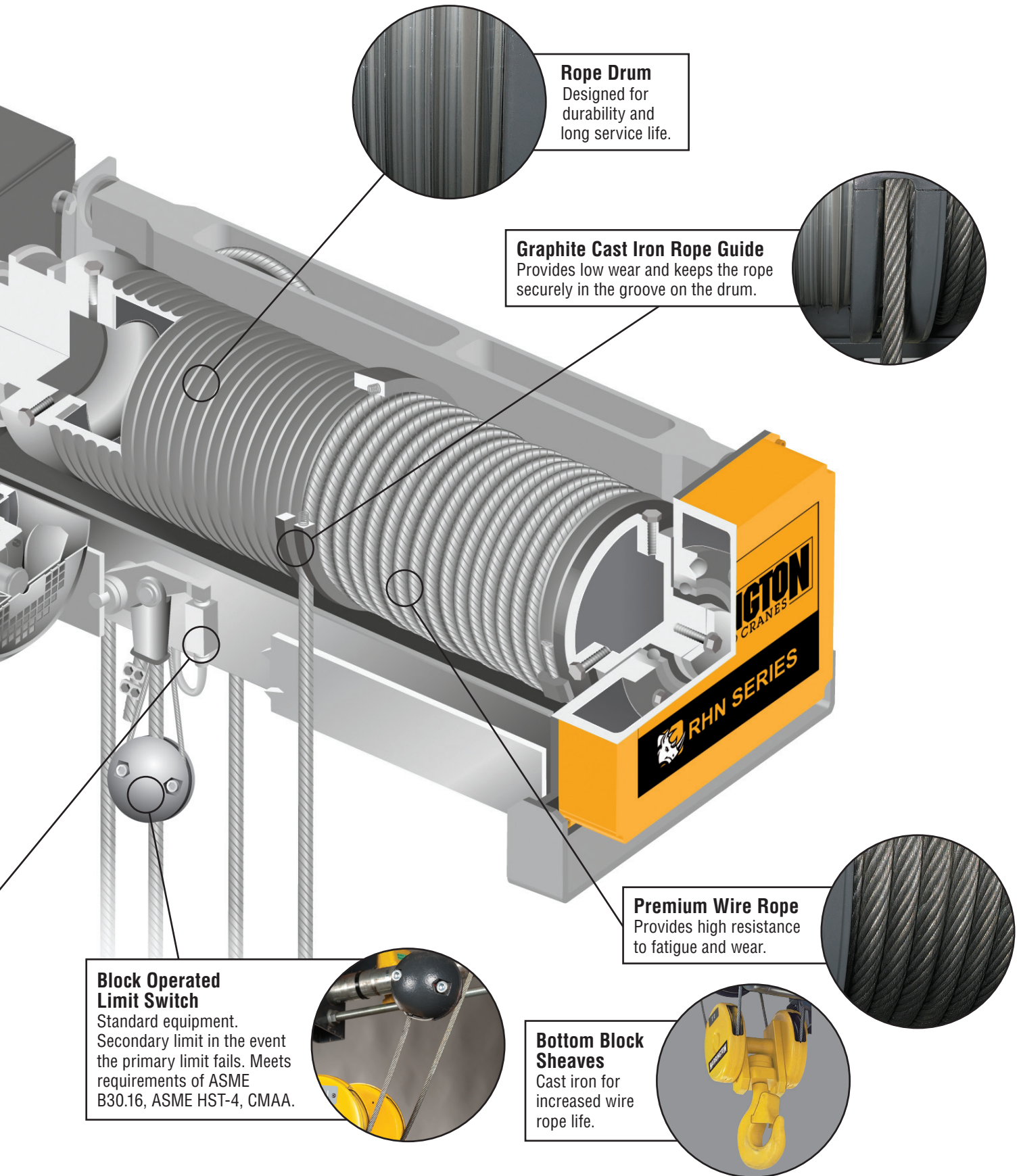

Rope Drum
Designed for durability and long service life.



Graphite Cast Iron Rope Guide
Provides low wear and keeps the rope securely in the groove on the drum.

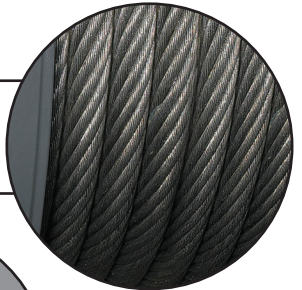

Premium Wire Rope
Provides high resistance to fatigue and wear.

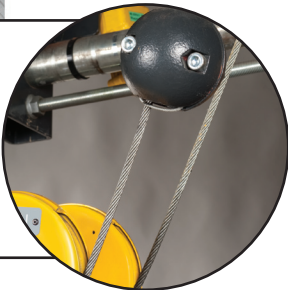

Block Operated Limit Switch
Standard equipment. Secondary limit in the event the primary limit fails. Meets requirements of ASME B30.16, ASME HST-4, CMAA.



Bottom Block Sheaves
Cast iron for increased wire rope life.

RHN Series Electric Wire Rope Deck/Base Mounted Hoists

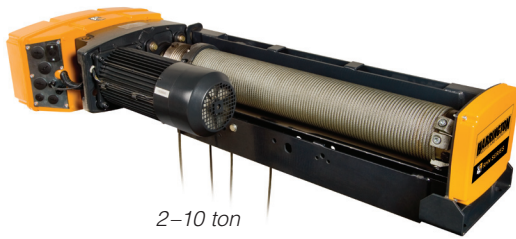

Harrington's high performance RHN Series Deck / Base Mounted electric wire rope hoists feature a compact, modular design that is perfect for stationary applications or combined with a double girder trolley for double girder crane systems. The basic design is ideal for hoist retro-fits on existing crane applications.

Features and Benefits

Premium Wire Rope

Provides high resistance to fatigue and wear.

Graphite Cast Iron Rope Guide

Provides low wear and keeps the rope securely in the groove on the drum.

Load Limiter

Reduces the potential for making hazardous, over-capacity lifts. Overloading the hoist electrically activates the load limiter sensor, making hoist lifting inoperable.

Helical Gearing

Provides maintenance free, smooth & quiet operation.

Easy Maintenance Control Panel

IP55 protection with modern controls. Components mounted on DIN rail. Equipped with main line contactor.

Heavy Duty Electromagnetic Brake

Totally enclosed and fan cooled to ensure long life. Easy to inspect. 1 million cycles.

Heavy Duty Cylindrical Motor

Fan cooled (TEFC) with class F insulation and a ribbed frame for maximum cooling and durability. High protection class IP55 and positive temperature control (PTC) thermal sensors.

Bottom Block Sheaves

Cast iron for increased wire rope life.

Rope Drum

Designed for durability and long service life.

Adjustable Geared Limit Switch

Operation of switch set for upper and lower block position and emergency limit.

Motor Management

Equipped with overload cut-off and count hour meter.

Block Operated Limit Switch

Standard equipment. Secondary limit in the event the primary limit fails. Meets requirements of ASME B30.16, ASME HST-4, CMAA.

Standard Hoist Specifications

Capacity Range

2 – 20 ton

Standard Voltage

208 / 230 / 460 / 575-3-60

RHN models are not reconnectable

Control Voltage

110V

Duty Cycle

30 / 10 min

Classification

ASME H4

ISO M5 or M4

FEM 2M or 1Am

Conformance

ASME B30.16

CMAA

UL508A

CSA C22.2 NO.14

Ratings

Hoist – IP55

Standard Lift

20' or 33'

Reeving

4/1 (four-part single reeved)

Operating Conditions

Recommended for -4° to +104° F and humidity of 85% or less.

Adjustable Geared Limit Switch

Upper and lower standard

Mounting

Deck / Base mount

Consult Customer Service for Suspended Mount applications

Pendant & Pendant Cord

Optional

Power Supply Cord

Optional

Variable Frequency Drive (VFD)

Consult Customer Service

HARRINGTON RHN SERIES ELECTRIC WIRE ROPE HOISTS

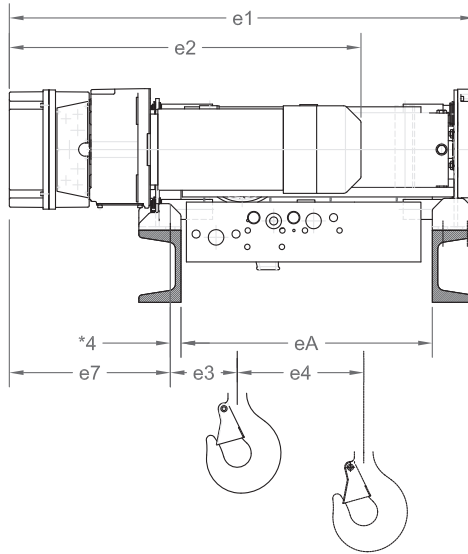
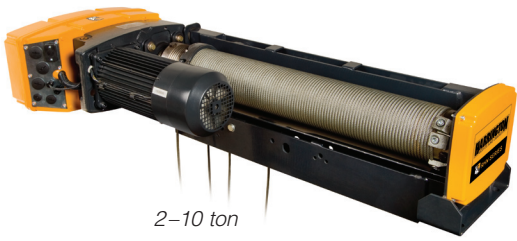

2-10 ton

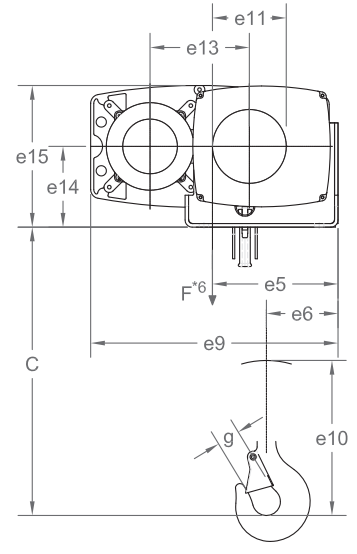

2-10 ton

DECK/BASE MOUNTED HOISTS—SPECIFICATIONS

| Capacity (t) | Product Code | Lift (ft) | Dual Lifting Speed (ft/min) | Reeving (parts/reeving) | Rope (mm) | Dual Speed Lifting Motor 3 Phase 60Hz | | | | Net Weight (lbs) |
|--------------|------------------|-----------|-----------------------------|-------------------------|-----------|--|----------------------|-----------|----------|------------------|
| | | | | | | Output (Hp) | Rated Current (amps) | | | |
| | | | | | | | @208/230V | @460V | @575V | |
| 2 | RHN02D-20A-20D-① | 20 | 20/3.5 | 4/1 | 7 | 5.8/0.9 | 17.4/8.4 | 8.3/4.0 | 6.6/3.2 | 353 |
| | RHN02D-33A-20D-① | 33 | | | | | | | | 375 |
| 3 | RHN03D-20A-20D-① | 20 | 20/3.5 | 4/1 | 7 | 5.8/0.9 | 17.4/8.4 | 8.3/4.0 | 6.6/3.2 | 353 |
| | RHN03D-33A-20D-① | 33 | | | | | | | | 375 |
| 5 | RHN05D-20B-20D-① | 20 | 20/3.5 | 4/1 | 9 | 7.2/1.2 | 21.7/11.3 | 10.0/5.4 | 8.3/4.3 | 452 |
| | RHN05D-33B-20D-① | 33 | | | | | | | | 485 |
| 7 1/2 | RHN08D-20C-20D-① | 20 | 20/3.5 | 4/1 | 12.5 | 14.8/2.1 | 41.8/20.9 | 20.0/10.0 | 16.0/8.0 | 1025 |
| | RHN08D-33C-20D-① | 33 | | | | | | | | 1102 |
| 10 | RHN10D-20C-20D-① | 20 | 20/3.5 | 4/1 | 12.5 | 14.8/2.1 | 41.8/20.9 | 20.0/10.0 | 16.0/8.0 | 1025 |
| | RHN10D-33C-20D-① | 33 | | | | | | | | 1102 |

① 1 = 208V - 3ph - 60Hz
 2 = 230V - 3ph - 60Hz
 4 = 460V - 3ph - 60Hz
 5 = 575V - 3ph - 60Hz

Consult Customer Service for Suspended Mount applications.

RHN Series Electric Wire Rope Deck/Base Mounted Hoists

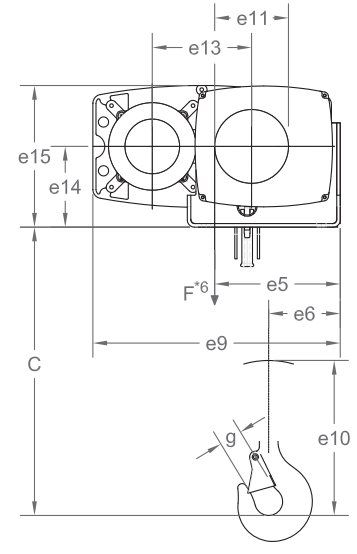
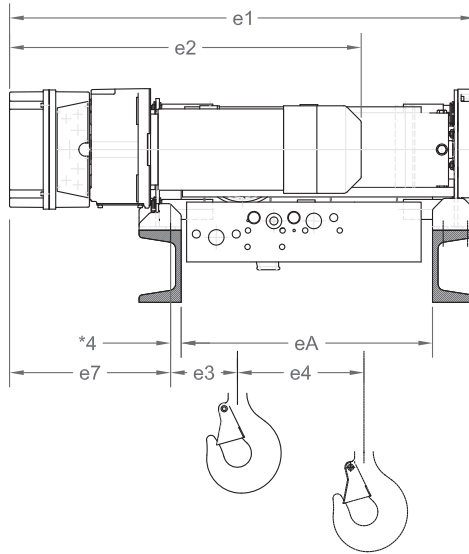
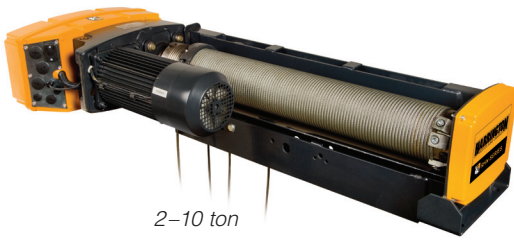

DECK/BASE MOUNTED HOISTS—DIMENSIONS

| Capacity (t) | Product Code | Headroom C (in) | e1 (in) | e2 (in) | e3 (in) | e4 (in) | e5 (in) | e6 (in) | e7 (in) | e9 (in) | e10 (in) | e11 (in) | e13 (in) | e14 (in) | e15 (in) | eA (in) |
|--------------|------------------|-----------------|---------|---------|---------|---------|---------|---------|---------|---------|----------|----------|----------|----------|----------|---------|
| 2 | RHN02D-20A-20D-① | 16.7 | 40.9 | 28.5 | 6.3 | 4.6 | 9.0 | 4.8 | 13.9 | 21.3 | 11.5 | 5.0 | 7.2 | 6.3 | 11.0 | 22.2 |
| | RHN02D-33A-20D-① | | 52.5 | | 6.2 | 7.6 | | | | | | | | | | 33.8 |
| 3 | RHN03D-20A-20D-① | 16.7 | 40.9 | 28.5 | 6.3 | 4.6 | 9.0 | 4.8 | 13.9 | 21.3 | 11.5 | 5.0 | 7.2 | 6.3 | 11.0 | 22.2 |
| | RHN03D-33A-20D-① | | 52.5 | | 6.2 | 7.6 | | | | | | | | | | 33.8 |
| 5 | RHN05D-20B-20D-① | 18.9 | 41.3 | 31.2 | 6.4 | 4.3 | 11.2 | 5.9 | 14.3 | 22.0 | 13.8 | 6.6 | 8.8 | 7.2 | 12.9 | 22.2 |
| | RHN05D-33B-20D-① | | 52.9 | | | 7.2 | | | | | | | | | | 33.8 |
| 7 1/2 | RHN08D-20C-20D-① | 24.6 | 48.0 | 39.3 | 9.5 | 4.6 | 14.1 | 7.5 | 17.2 | 28.6 | 18.2 | 8.6 | 11.7 | 9.4 | 16.9 | 24.6 |
| | RHN08D-33C-20D-① | | 60.4 | | | 7.8 | | | | | | | | | | 37.0 |
| 10 | RHN10D-20C-20D-① | 24.6 | 48.0 | 39.3 | 9.5 | 4.6 | 14.1 | 7.5 | 17.2 | 28.6 | 18.2 | 8.6 | 11.7 | 9.4 | 16.9 | 24.6 |
| | RHN10D-33C-20D-① | | 60.4 | | | 7.8 | | | | | | | | | | 37.0 |

- ① 1 = 208V - 3ph - 60Hz
- 2 = 230V - 3ph - 60Hz
- 4 = 460V - 3ph - 60Hz
- 5 = 575V - 3ph - 60Hz

Consult Customer Service for Suspended Mount applications.
See page 15 for dimensions of Deck/Base Mounted attachment points.
*4 - Keep this dimension as small as possible.
*6 - Traction on drum.

HARRINGTON RHN SERIES ELECTRIC WIRE ROPE HOISTS

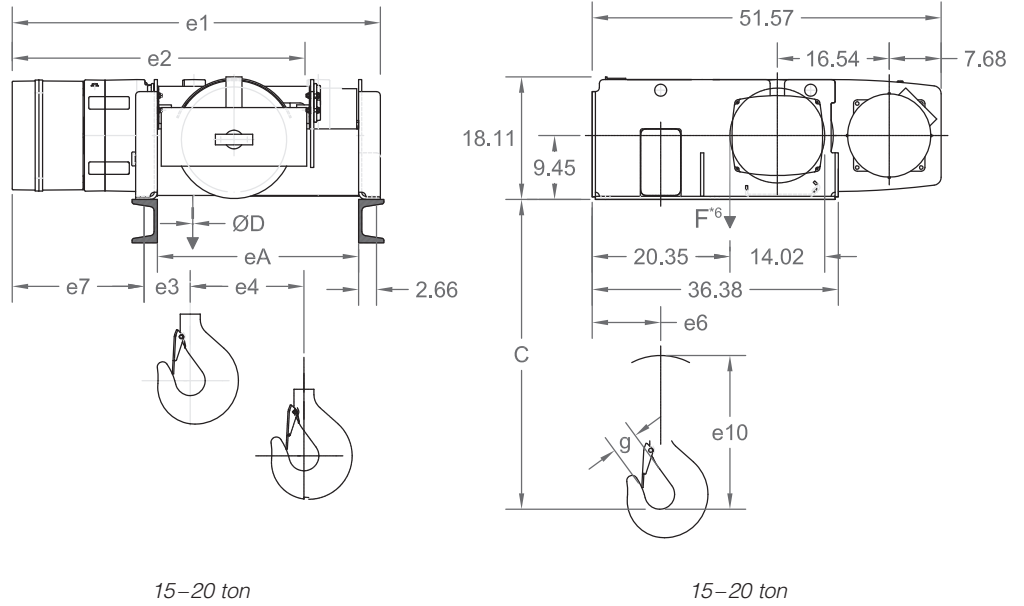

DECK/BASE MOUNTED HOISTS—LARGE CAPACITY SPECIFICATIONS

| Capacity (t) | Product Code | Lift (ft) | Dual Lifting Speed (ft/min) | Reeving (parts/reeving) | Rope (mm) | Dual Speed Lifting Motor 3 Phase 60Hz | | | | Net Weight (lbs) |
|--------------|------------------|-----------|-----------------------------|-------------------------|-----------|---------------------------------------|----------------------|-----------|-----------|------------------|
| | | | | | | Output (Hp) | Rated Current (amps) | | | |
| | | | | | | | @208/230V | @460V | @575V | |
| 15 | RHN15D-20D-16D-① | 20 | 16/2.5 | 4/1 | 20 | 24.1/4.0 | 66.9/27.2 | 32.0/13.0 | 25.6/10.4 | 2271 |
| | RHN15D-33D-16D-① | 33 | | | | | | | | 2436 |
| 20 | RHN20D-20D-16D-① | 20 | 16/2.5 | 4/1 | 20 | 24.1/4.0 | 66.9/27.2 | 32.0/13.0 | 25.6/10.4 | 2271 |
| | RHN20D-33D-16D-① | 33 | | | | | | | | 2436 |

①
 1 = 208V - 3ph - 60Hz
 2 = 230V - 3ph - 60Hz
 4 = 460V - 3ph - 60Hz
 5 = 575V - 3ph - 60Hz

DECK/BASE MOUNTED HOISTS—LARGE CAPACITY DIMENSIONS

| Capacity (t) | Product Code | Headroom C (in) | e1 (in) | e2 (in) | e3 (in) | e4 (in) | e6 (in) | e7 (in) | e10 (in) | eA (in) |
|--------------|------------------|-----------------|---------|---------|---------|---------|---------|---------|----------|---------|
| 15 | RHN15D-20D-16D-① | 31.1 | 54.4 | 43.5 | 13.4 | 4.6 | 10.9 | 19.5 | 29.8 | 28.3 |
| | RHN15D-33D-16D-① | | 66.7 | | | 7.6 | | | | 40.6 |
| 20 | RHN20D-20D-16D-① | 31.1 | 54.4 | 43.5 | 13.4 | 4.6 | 10.9 | 19.5 | 29.8 | 28.3 |
| | RHN20D-33D-16D-① | | 66.7 | | | 7.6 | | | | 40.6 |

①
 1 = 208V - 3ph - 60Hz
 2 = 230V - 3ph - 60Hz
 4 = 460V - 3ph - 60Hz
 5 = 575V - 3ph - 60Hz

Consult Customer Service for Suspended Mount applications.
 See page 16 for dimensions of Deck/Base Mounted attachment points.
 *6 - Traction on drum.

RHN Series Electric Wire Rope Ultra-Low Headroom Trolley Hoists



2–15 ton

Harrington's RHN Series Ultra-Low Headroom trolley hoists combine our superior RHN hoist with an ultra-low headroom trolley and is the ideal solution for top running and underhung overhead bridge cranes. The compact body and short end approach result in the longest hook travel possible in facilities with limited usable space.

Features and Benefits

Rubber Trolley Bumpers

Standard feature on all trolleys. Provides protection from collisions. Complies with ASME standards.

Trolley Motor and Brake

Cylindrical motor with standard brake provides smooth, low-vibration acceleration and braking.

Built-In Drop Stops

Important feature provides additional security for the operator and the equipment.

Trolley Wheels

2 and 3 ton are operational on 3 1/4" patented track.

Premium Wire Rope

Provides high resistance to fatigue and wear.

Graphite Cast Iron Rope Guide

Provides low wear and keeps the rope securely in the groove on the drum.

Load Limiter

Reduces the potential for making hazardous, over-capacity lifts. Overloading the hoist electrically activates the load limiter sensor, making hoist lifting inoperable.

Helical Gearing

Provides maintenance free, smooth & quiet operation.

Easy Maintenance Control Panel

IP55 protection with modern controls. Components mounted on DIN rail. Equipped with main line contactor.

Heavy Duty Cylindrical Motor

Fan cooled (TEFC) with class F insulation and a ribbed frame for maximum cooling and durability. High protection class IP55 and positive temperature control (PTC) thermal sensors.

Heavy Duty Electromagnetic Brake

Totally enclosed and fan cooled to ensure long life. Easy to inspect. 1 million cycles.

Bottom Block Sheaves

Cast iron for increased wire rope life.

Rope Drum

Designed for durability and long service life.

Adjustable Geared Limit Switch

Operation of switch set for upper and lower block position and emergency limit.

Motor Management

Equipped with overload cut-off and count hour meter.

Block Operated Limit Switch

Standard equipment. Secondary limit in the event the primary limit fails. Meets requirements of ASME B30.16, ASME HST-4, CMAA.

Standard Hoist/Trolley Specifications

Capacity Range

2 – 15 ton

Standard Voltage

208 / 230 / 460 / 575-3-60

RHN models are not reconnectable.

Control Voltage

110V

Duty Cycle

30 / 10 min

Ratings

Hoist / Trolley – IP55

Classification

ASME H4
ISO M5 or M4
FEM 2M or 1Am

Conformance

ASME B30.16
CMAA
UL508A
CSA 22.2 NO.14

Operating Conditions

Recommended for -4° to +104° F and humidity of 85% or less.

Mounting

Ultra-Low Headroom

Pendant & Pendant Cord

Optional

Power Supply Cord

Optional

Wheels

Will operate on a tapered or flat flanged beam flange.

Variable Frequency Drive (VFD)

Hoist - Consult Customer Service
Trolley - Consult Customer Service

HARRINGTON RHN SERIES ELECTRIC WIRE ROPE HOISTS



2-15 ton

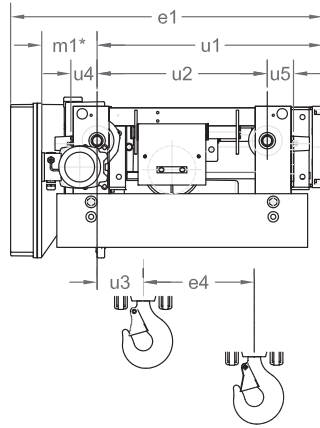

2-15 ton

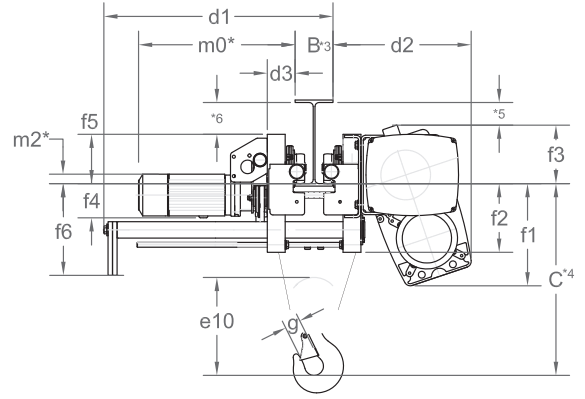

2-15 ton

ULTRA-LOW HEADROOM TROLLEY HOISTS—HOIST SPECIFICATIONS

| Capacity (t) | Product Code | Lift (ft) | Dual Lifting Speed (ft/min) | Reeving (parts/reeving) | Rope (mm) | Dual Speed Lifting Motor 3 Phase 60Hz | | | | Net Weight (lbs) |
|--------------|-------------------|-----------|-----------------------------|-------------------------|-----------|--|----------------------|-----------|----------|------------------|
| | | | | | | Output (Hp) | Rated Current (amps) | | | |
| | | | | | | | @208/230V | @460V | @575V | |
| 2 | RHN02U-20A-20DD-① | 20 | 20/3.5 | 4/1 | 7 | 5.8/0.9 | 17.4/8.4 | 8.3/4.0 | 6.6/3.2 | 617 |
| | RHN02U-33A-20DD-① | 33 | | | | | | | | 650 |
| 3 | RHN03U-20A-20DD-① | 20 | 20/3.5 | 4/1 | 7 | 5.8/0.9 | 17.4/8.4 | 8.3/4.0 | 6.6/3.2 | 617 |
| | RHN03U-33A-20DD-① | 33 | | | | | | | | 650 |
| 5 | RHN05U-20B-20DD-① | 20 | 20/3.5 | 4/1 | 9 | 7.2/1.2 | 21.7/11.3 | 10.0/5.4 | 8.3/4.3 | 728 |
| | RHN05U-33B-20DD-① | 33 | | | | | | | | 787 |
| 7 1/2 | RHN08U-20C-20DD-① | 20 | 20/3.5 | 4/1 | 12.5 | 14.8/2.1 | 41.8/20.9 | 20.0/10.0 | 16.0/8.0 | 1664 |
| | RHN08U-33C-20DD-① | 33 | | | | | | | | 1753 |
| 10 | RHN10U-20C-20DD-① | 20 | 20/3.5 | 4/1 | 12.5 | 14.8/2.1 | 41.8/20.9 | 20.0/10.0 | 16.0/8.0 | 1664 |
| | RHN10U-33C-20DD-① | 33 | | | | | | | | 1753 |
| 15 | RHN15U-28D-12DD-① | 28 | 12/2.0 | 4/1 | 14 | 14.8/2.1 | 41.8/20.9 | 20.0/10.0 | 16.0/8.0 | 3086 |
| | RHN15U-46D-12DD-① | 46 | | | | | | | | 3439 |

① 1 = 208V - 3ph - 60Hz
 2 = 230V - 3ph - 60Hz
 4 = 460V - 3ph - 60Hz
 5 = 575V - 3ph - 60Hz

RHN Series Electric Wire Rope Ultra-Low Headroom Trolley Hoists



2–15 ton

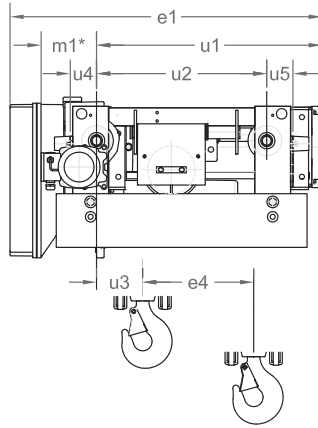

2–15 ton

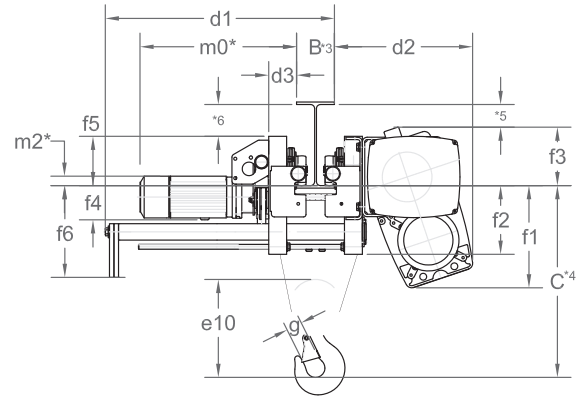

2–15 ton

ULTRA-LOW HEADROOM TROLLEY HOISTS—TROLLEY SPECIFICATIONS

| Capacity (t) | Product Code | Standard Flange Range B* (in) | Dual Speed Traversing Motor 80 and 20 ft/min | | | | |
|--------------|-------------------|-------------------------------|--|----------------------|---------|---------|---------|
| | | | Output (Hp) | Rated Current (amps) | | | |
| | | | | @208V | @230V | @460V | @575V |
| 2 | RHN02U-20A-20DD-① | 3.25-12 | 0.15/0.59 | 2.3/3.0 | 2.0/2.6 | 1.0/1.3 | 0.8/1.0 |
| | RHN02U-33A-20DD-① | | | | | | |
| 3 | RHN03U-20A-20DD-① | 3.25-12 | 0.15/0.59 | 2.3/3.0 | 2.0/2.6 | 1.0/1.3 | 0.8/1.0 |
| | RHN03U-33A-20DD-① | | | | | | |
| 5 | RHN05U-20B-20DD-① | 3.63-12 | 0.15/0.59 | 2.3/3.0 | 2.0/2.6 | 1.0/1.3 | 0.8/1.0 |
| | RHN05U-33B-20DD-① | | | | | | |
| 7 1/2 | RHN08U-20C-20DD-① | 4.63-12 | 0.21/0.89 | 2.8/3.7 | 2.4/3.2 | 1.2/1.6 | 1.0/1.3 |
| | RHN08U-33C-20DD-① | | | | | | |
| 10 | RHN10U-20C-20DD-① | 4.63-12 | 0.21/0.89 | 2.8/3.7 | 2.4/3.2 | 1.2/1.6 | 1.0/1.3 |
| | RHN10U-33C-20DD-① | | | | | | |
| 15 | RHN15U-28D-12DD-① | 8.75-12 | 0.48/2.01 | 3.2/6.9 | 2.8/6.0 | 1.4/3.0 | 1.1/2.4 |
| | RHN15U-46D-12DD-① | | | | | | |

- ① 1 = 208V – 3ph – 60Hz
- 2 = 230V – 3ph – 60Hz
- 4 = 460V – 3ph – 60Hz
- 5 = 575V – 3ph – 60Hz

*Optional wider flange ranges available up to 19.7 inches. Consult Customer Service.

HARRINGTON RHN SERIES ELECTRIC WIRE ROPE HOISTS



2-15 ton

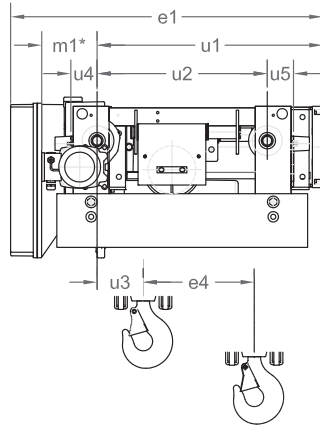

2-15 ton

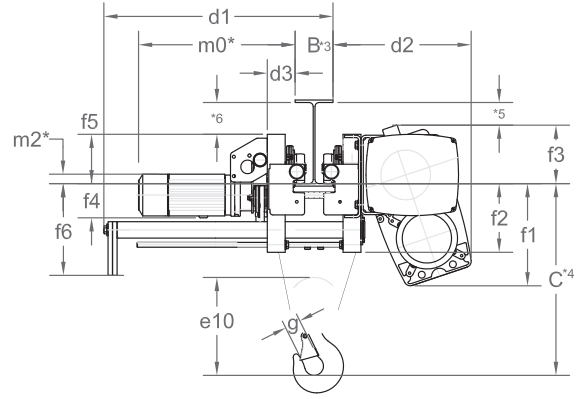

2-15 ton

ULTRA-LOW HEADROOM TROLLEY HOISTS—DIMENSIONS

| Capacity (t) | Product Code | e1 (in) | e4 (in) | e10 (in) | d1 (in) | d2 (in) | d3 (in) | f1 (in) | f2 (in) | f3 (in) | f4 (in) | f5 (in) | f6 (in) | u1 (in) | u2 (in) | u3 (in) | u4 (in) | u5 (in) |
|--------------|-------------------|---------|---------|----------|---------|---------|---------|---------|---------|---------|---------|---------|---------|---------|---------|---------|---------|---------|
| 2 | RHN02U-20A-20DD-① | 44.3 | 4.6 | 11.5 | 28.7 | 17.5 | 3.7 | 13.9 | 8.9 | 6.5 | 4.8 | 6.1 | 11.9 | 30.0 | 22.4 | 9.1 | 3.0 | 3.8 |
| | RHN02U-33A-20DD-① | 59.8 | 7.6 | | | | | | | | | | 10.7 | 41.6 | 34.1 | 9.0 | | |
| 3 | RHN03U-20A-20DD-① | 44.3 | 4.6 | 11.5 | 28.7 | 17.5 | 3.7 | 13.9 | 8.9 | 6.5 | 4.8 | 6.1 | 11.9 | 30.0 | 22.4 | 9.1 | 3.0 | 3.8 |
| | RHN03U-33A-20DD-① | 59.8 | 7.6 | | | | | | | | | | 10.7 | 41.6 | 34.1 | 9.0 | | |
| 5 | RHN05U-20B-20DD-① | 49.1 | 4.3 | 13.8 | 31.4 | 18.2 | 3.7 | 13.5 | 9.1 | 7.7 | 4.8 | 6.5 | 12.1 | 29.8 | 22.4 | 9.9 | 3.5 | 3.5 |
| | RHN05U-33B-20DD-① | 60.9 | 7.2 | | | | | | | 8.1 | | 8.1 | 10.9 | 47.3 | 40.0 | 15.8 | | |
| 7 1/2 | RHN08U-20C-20DD-① | 47.2 | 4.6 | 18.2 | 37.0 | 22.9 | 4.5 | 16.1 | 11.4 | 10.7 | 5.9 | 9.8 | 15.7 | 33.7 | 24.6 | 12.6 | 4.6 | 4.6 |
| | RHN08U-33C-20DD-① | 59.6 | 7.8 | | | | | | | | | | 15.0 | 46.1 | 37.0 | 12.6 | | |
| 10 | RHN10U-20C-20DD-① | 47.2 | 4.6 | 18.2 | 37.0 | 22.9 | 4.5 | 16.1 | 11.4 | 10.7 | 5.9 | 9.8 | 15.7 | 33.7 | 24.6 | 12.6 | 4.6 | 4.6 |
| | RHN10U-33C-20DD-① | 59.6 | 7.8 | | | | | | | | | | 15.0 | 46.1 | 37.0 | 12.6 | | |
| 15* | RHN15U-28D-12DD-① | 53.9 | 4.6 | 23.0 | 44.4 | 25.1 | 6.6 | 24.5 | 11.8 | 10.0 | 6.6 | 10.0 | 16.7 | 38.0 | 40.7 | 15.9 | 6.6 | 6.6 |
| | RHN15U-46D-12DD-① | 66.1 | 7.7 | | | | | | | | | | 15.2 | 58.1 | 60.8 | 23.7 | | |

- ① 1 = 208V – 3ph – 60Hz
- 2 = 230V – 3ph – 60Hz
- 4 = 460V – 3ph – 60Hz
- 5 = 575V – 3ph – 60Hz

*Refer to page 14 for motor dimensions m0, m1, and m2.

*3 – Refer to page 14 for flange range dimension B (Standard Ultra-Low Headroom trolleys are suitable for use on S or W shaped beams).

*4 – Refer to page 14 for headroom dimension C.

*5/*6 – Observe clearance dimensions.

RHN Series Electric Wire Rope Ultra-Low Headroom Trolley Hoists

ULTRA-LOW HEADROOM TROLLEY HOIST—HEADROOM

| Capacity (t) | Flange Range B (in) | Headroom C* (in) | Headroom C for 6 inch Flange (in) |
|--------------|---------------------|------------------|-----------------------------------|
| 2 3 | 3.25-4.69 | 16.54 | 16.2 |
| | 4.69-6.69 | 17.9+(-0.29*T) | |
| | 6.69-12 | 12.1+(0.58*T) | |
| 5 | 3.625-4.69 | 20.67 | 20.5 |
| | 4.69-6.69 | 21.1+(-0.10*T) | |
| | 6.69-12 | 22.0+(-0.23*T) | |
| 7.5 10 | 4.625-6.69 | 25.6+(-0.29*T) | 23.9 |
| | 6.69-12 | 25.9+(-0.35*T) | |
| 15 | 8.75-12 | 31.4+(-0.31*T) | 28.6** |

*T in formulas is the exact beam flange width in inches.
**Headroom value for 9 inch flange.

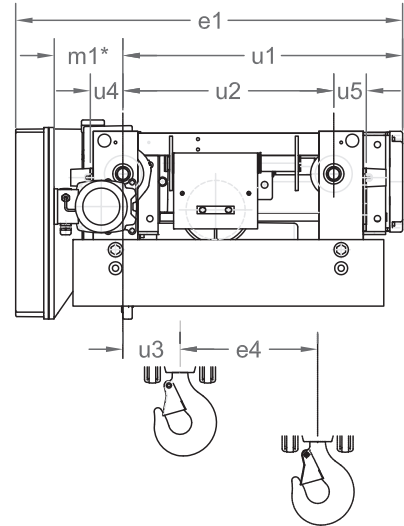

ULTRA-LOW HEADROOM TROLLEY—MOTOR DIMENSIONS*

| Capacity (t) | Product Code | m0 (in) | m1 (in) | m2 (in) |
|--------------|-------------------|---------|---------|---------|
| 2 | RHN02U-20A-20DD-① | 20.6 | 7.4 | 1.3 |
| | RHN02U-33A-20DD-① | | | |
| 3 | RHN03U-20A-20DD-① | 20.6 | 7.4 | 1.3 |
| | RHN03U-33A-20DD-① | | | |
| 5 | RHN05U-20B-20DD-① | 20.6 | 7.4 | 1.3 |
| | RHN05U-33B-20DD-① | | | |
| 7 1/2 | RHN08U-20C-20DD-① | 22.3 | 9.5 | 0.8 |
| | RHN08U-33C-20DD-① | | | |
| 10 | RHN10U-20C-20DD-① | 22.3 | 9.5 | 0.8 |
| | RHN10U-33C-20DD-① | | | |
| 15 | RHN15U-28D-12DD-① | 26.5 | 10.1 | 1.3 |
| | RHN15U-46D-12DD-① | | | |

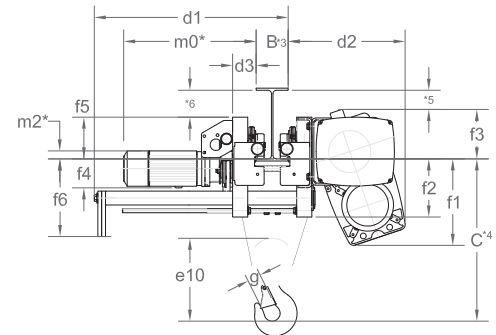

①
1 = 208V - 3ph - 60Hz
2 = 230V - 3ph - 60Hz
4 = 460V - 3ph - 60Hz
5 = 575V - 3ph - 60Hz

*Refer to page 12 for trolley motor specifications.